

CSA8000 and TDS8000 Programmer Guide

PHP013903

Version 3.00

This document duplicates the information found in the CSA8000 and TDS8000 Programmer Guide, which is part of the Online Help system of 8000 Series instruments. This document is provided so that you have a version that can easily be printed.

This document is not orderable and is not available in printed format.

Table of Contents

Preface	11
Copyright and Version Information.....	11
Getting Started	12
Introduction.....	12
Remote Communications.....	12
Documentation.....	15
Command Syntax	16
Syntax Overview.....	16
Command and Query Structure.....	16
Clearing the Instrument.....	18
Command Entry.....	18
Constructed Mnemonics.....	20
Argument Types.....	22
Command Groups	25
Acquisition Command Group.....	25
Calibration Command Group.....	26
Compensation Command Group.....	27
Cursor Command Group.....	28
Display Control Command Group.....	29
Hard Copy Command Group.....	31
Histogram Command Group.....	32
Horizontal Command Group.....	33
Mask Command Group.....	37
Math Command Group.....	39
Measurement Command Group.....	40
Miscellaneous Command Group.....	44
Save and Recall Command Group.....	44
Status and Error Command Group.....	45
System Command Group.....	46
TDR Command Group.....	47
Trigger Command Group.....	48
Vertical Command Group.....	49
Waveform Database Command Group.....	51
Waveform Transfer Command Group.....	53
Commands	57
*CLS.....	57
*ESE.....	57
*ESR?.....	58
*IDN?.....	58
*LRN?.....	59
*OPC.....	59
*PSC.....	60
*RST.....	61
*SRE.....	62
*STB?.....	62
*WAI.....	63
ACQUIRE:CURRENTcount:ACQWfms?.....	63
ACQUIRE:CURRENTcount:HISTHits?.....	63
ACQUIRE:CURRENTcount:HISTWfms?.....	64

ACQuire:CURRentcount:MASKHits<n>?	64
ACQuire:CURRentcount:MASKSamples?	65
ACQuire:CURRentcount:MASKTHits?	66
ACQuire:CURRentcount:MASKWfms?	66
ACQuire:DATA:CLEAR	67
ACQuire:MODE	67
ACQuire:NUMAVg	69
ACQuire:SAVEFile:SAVEScreen	69
ACQuire:SAVEFile:SAVEWfm	70
ACQuire:STATE	71
ACQuire:STOPAfter:ACTion	72
ACQuire:STOPAfter:BELL	73
ACQuire:STOPAfter:CONDition	74
ACQuire:STOPAfter:COUNT	76
ACQuire:STOPAfter:MODE	77
ACQuire:STOPAfter?	77
ACQuire?	78
ALLEv?	78
AUTOSet	79
AUTOSet:STOP	79
AUTOSet:TYPE	80
Group	80
AUTOSet:UNDO	81
BUSY?	81
CALibrate:DATE:CH<x>?	82
CALibrate:DATE:MAInframe?	82
CALibrate:DCCALibrator	83
CALibrate:HOSTInfo:CH<x>?	83
CALibrate:LOCK:STATus?	83
CALibrate:STATus:CH<x>?	84
CALibrate:STATus:MAInframe?	84
CALibrate:TEMPerature:CH<x>?	85
CALibrate:TEMPerature:MAInframe?	85
CALibrate:UPDATEinfo:ALL	85
CALibrate:UPDATEinfo:CH<x>	86
CALibrate:UPDATEinfo:MAInframe	86
CH<x>:BANdwidth:LIST?	86
CH<x>:BANdwidth:VALue	87
CH<x>:DESkew	88
CH<x>:EXTAtten:MODE	89
CH<x>:EXTAtten:VALue	89
CH<x>:FILTer:LIST?	90
CH<x>:FILTer:VALue	91
CH<x>:OFFSet	93
CH<x>:POSition	94
CH<x>:SCAle	95
CH<x>:UNIts	96
CH<x>:WFMLabel	97
CH<x>:WLENgth:LIST?	97
CH<x>:WLENgth:VALue	98
CH<x>?	98
COMPensate:ALL	99
COMPensate:CH<x>	99
COMPensate:DARKLev:CH<x>	100
COMPensate:DATE:CH<x>?	100
COMPensate:DATE:MAInframe?	100
COMPensate:MAInframe	101

COMPensate:OPTGAIN:CH<x>	101
COMPensate:RECAI:FACTory:ALL	102
COMPensate:RECAI:FACTory:CH<x>	102
COMPensate:RECAI:FACTory:MAInframe	102
COMPensate:RECAI:USER:ALL	102
COMPensate:RECAI:USER:CH<x>	103
COMPensate:RECAI:USER:MAInframe	103
COMPensate:RESults:VERBoSe?	103
COMPensate:RESults?	104
COMPensate:SAVe:USER:ALL	104
COMPensate:SAVe:USER:CH<x>	104
COMPensate:SAVe:USER:MAInframe	105
COMPensate:STATus:CH<x>?	105
COMPensate:STATus:MAInframe?	105
COMPensate:TEMPerature:CH<x>?	106
COMPensate:TEMPerature:MAInframe?	106
CURSor:CURSor<x>:COLOR	106
CURSor:CURSor<x>:SOUrce	108
CURSor:FUNcTion	109
CURSor:HBArs:DELTA?	110
CURSor:HBArs:POSition<x>	110
CURSor:HBArs?	111
CURSor:SElect	111
CURSor:VBArS?	112
CURSor:VBArS:DELTA?	112
CURSor:VBArS:POSition<x>	113
CURSor:WAVEform:HDELTA?	113
CURSor:WAVEform:HPOS<x>?	114
CURSor:WAVEform:POSition<x>	114
CURSor:WAVEform:VDELTA?	115
CURSor:WAVEform?	115
CURSor?	115
CURVe	116
DATa	117
DATa:DESTination	118
DATa:ENCdg	118
DATa:SOUrce	120
DATa:STARt	121
DATa:STOP	121
DATa:TIMEbase	122
DATE	123
DELEte:WAVEform	124
DESE	124
DISplay:COLor:BACKground	125
DISplay:COLor:CURSOR<x>	126
DISplay:COLor:FOREground	128
DISplay:COLor:HISTogram	129
DISplay:COLor:MASK	130
DISplay:COLor?	131
DISplay:CURSReadout	132
DISplay:GRAticule:HDIVS?	133
DISplay:GRAticule:STYLE	133
DISplay:GRAticule:VDIVS?	134
DISplay:GRAticule?	134
DISplay:HISTReadout	135
DISplay:INTERPolat	135
DISplay:MASKReadout	137

DISplay:MEASBar	137
DISplay:MEASReadout	138
DISplay:PERsistence	139
DISplay:SHOWVector	139
DISplay:STYLE	140
DISpLay:WFMReadout	141
DISplay?	142
EVENT?	142
EVMsg?	142
EVQty?	143
EXPort	143
FACTory	144
FILESystem:READFile? <file path>	145
HARDCopy	146
HARDCopy:FILEName	146
HARDCopy:FORMat	147
HARDCopy:INKSaver	148
HEADer	149
HIStogram:BOX	150
HIStogram:BOXPcnt	151
HIStogram:COLOR	152
HIStogram:COUNT	153
HIStogram:DISplay	153
HIStogram:ENABLE	154
HIStogram:MODE	154
HIStogram:SIze	155
HIStogram:SOUrce	156
HIStogram:STATistics:HITS?	157
HIStogram:STATistics:MEAN?	157
HIStogram:STATistics:MEDIAN?	157
HIStogram:STATistics:PEAKHits?	158
HIStogram:STATistics:PKTOPK?	158
HIStogram:STATistics:SIGMA<x>?	158
HIStogram:STATistics:WAVEforms?	159
HIStogram:STATistics?	159
HIStogram:STATistics:STDdev?	160
HIStogram:TYPE	160
HIStogram:WFMDB:STATE	161
HIStogram?	162
HORizontal:BITS:BITRate	162
HORizontal:BITS:STANdard	163
HORizontal:DIStance:DIELectric	166
HORizontal:DIStance:PVELocity	166
HORizontal:EXT10MHZref:FREQ	167
HORizontal:FRAMescan:AUTOPosition	167
HORizontal:FRAMescan:RESET	168
HORizontal:FRAMescan:SCANBits	169
HORizontal:FRAMescan:STARTBit	169
HORizontal:FRAMescan:STATE	170
HORizontal:MAG<x>:POStion	171
HORizontal:MAG<x>:RECORDLength	173
HORizontal:MAG<x>:REFPoint	174
HORizontal:MAG<x>:RESolution?	175
HORizontal:MAG<x>:SCAle	175
HORizontal:MAG<x>:TOFPoint?	176
HORizontal:MAG<x>:TOLPoint?	177
HORizontal:MAG<x>:VIEW	178

HORizontal:MAG<x>?	179
HORizontal:MAIn:POSition	179
HORizontal:MAIn:RECOrdlength	181
HORizontal:MAIn:REFPoint	182
HORizontal:MAIn:RESolution?	184
HORizontal:MAIn:SCAle	184
HORizontal:MAIn:TOFPoint?	185
HORizontal:MAIn:TOLPoint?	186
HORizontal:MAIn?	186
HORizontal:MATH<x>:MAG<x>:POSition?	187
HORizontal:MATH<x>:MAG<x>:RECORDLength?	187
HORizontal:MATH<x>:MAG<x>:RESolution?	188
HORizontal:MATH<x>:MAG<x>:SCAle?	188
HORizontal:MATH<x>:MAG<x>:TOFPoint?	189
HORizontal:MATH<x>:MAG<x>:TOLPoint	189
HORizontal:MATH<x>:MAIn:POSition?	190
HORizontal:MATH<x>:MAIn:RECORDLength?	190
HORizontal:MATH<x>:MAIn:REFPoint?	191
HORizontal:MATH<x>:MAIn:RESolution?	191
HORizontal:MATH<x>:MAIn:SCAle?	191
HORizontal:MATH<x>:MAIn:TOFPoint?	192
HORizontal:MATH<x>:MAIn:TOLPoint?	192
HORizontal:REF<x>:MAG<x>:POSition?	193
HORizontal:REF<x>:MAG<x>:RECORDLength?	193
HORizontal:REF<x>:MAG<x>:RESolution?	194
HORizontal:REF<x>:MAG<x>:SCAle?	194
HORizontal:REF<x>:MAG<x>:TOFPoint?	195
HORizontal:REF<x>:MAG<x>:TOLPoint?	195
HORizontal:REF<x>:MAIn:POSition?	196
HORizontal:REF<x>:MAIn:RECORDLength?	196
HORizontal:REF<x>:MAIn:REFPoint?	197
HORizontal:REF<x>:MAIn:RESolution?	197
HORizontal:REF<x>:MAIn:SCAle?	197
HORizontal:REF<x>:MAIn:TOFPoint?	198
HORizontal:REF<x>:MAIn:TOLPoint?	198
HORizontal:TBMode	199
HORizontal:UNIts	200
HORizontal?	201
ID?	201
LOCK	202
MASK:AUTOSet:MODE	203
MASK:COLOr	203
MASK:COUNT	204
MASK:COUNT:SAMPles?	205
MASK:COUNT:STATE	205
MASK:COUNT:TOTal?	206
MASK:COUNT:WAVEforms?	206
MASK:DISPlay	207
MASK:MARGin:PERCent	207
MASK:MARGin:STATE	208
MASK:MASK<x>	209
MASK:MASK<x>:COUNT?	210
MASK:MASK<x>:NR_Pt?	210
MASK:MASK<x>:POInts	211
MASK:MASK<x>:POINTSPcnt	211
MASK:SOUrce	212
MASK:STANdard	213

MASK:WFMDB:STATE	217
MASK?	217
MATH<x>:DEFine	218
MATH<x>:FILTer:MODE	219
MATH<x>:FILTer:RISetime	220
MATH<x>:NUMavg	220
MATH<x>:POSition	221
MATH<x>:POSition	222
MATH<x>:SCAle	222
MATH<x>:SCAle	223
MATH<x>:UNITs?	224
MATH<x>:WFMLabel	225
MATH<x>?	225
MEASUrement:ALL:VALue?	226
MEASUrement:ANNOtations:STATE	226
MEASUrement:LIST	227
MEASUrement:LISTValue?	228
MEASUrement:MEAS<x>:ALL?	228
MEASUrement:MEAS<x>:EYEWindow	229
MEASUrement:MEAS<x>:GATing:STATE	230
MEASUrement:MEAS<x>:JITter	231
MEASUrement:MEAS<x>:MAXimum?	232
MEASUrement:MEAS<x>:MEAN?	232
MEASUrement:MEAS<x>:MINimum?	233
MEASUrement:MEAS<x>:NOISe	233
MEASUrement:MEAS<x>:REFLevel<x>:ABSolute:HIGH	234
MEASUrement:MEAS<x>:REFLevel<x>:ABSolute:LOW	235
MEASUrement:MEAS<x>:REFLevel<x>:ABSolute:MID	235
MEASUrement:MEAS<x>:REFLevel<x>:METHod	236
MEASUrement:MEAS<x>:REFLevel<x>:RELative:HIGH	238
MEASUrement:MEAS<x>:REFLevel<x>:RELative:LOW	239
MEASUrement:MEAS<x>:REFLevel<x>:RELative:MID	240
MEASUrement:MEAS<x>:REFLevel<x>?	241
MEASUrement:MEAS<x>:SETDefault	241
MEASUrement:MEAS<x>:SOURCE<x>:EDGE:DIRection	241
MEASUrement:MEAS<x>:SOURCE<x>:EDGE:SLOPe	243
MEASUrement:MEAS<x>:SOURCE<x>:EDGE?	244
MEASUrement:MEAS<x>:SOURCE<x>:GATE<x>:PCTPos	244
MEASUrement:MEAS<x>:SOURCE<x>:GATE<x>:POS	245
MEASUrement:MEAS<x>:SOURCE<x>:GATE<x>?	246
MEASUrement:MEAS<x>:SOURCE<x>:HILow:METHod	246
MEASUrement:MEAS<x>:SOURCE<x>:HILow:TRACK:HIGH: ENABle ..	248
MEASUrement:MEAS<x>:SOURCE<x>:HILow:TRACK:HIGH:VALue	250
MEASUrement:MEAS<x>:SOURCE<x>:HILow:TRACK:LOW:ENABle	251
MEASUrement:MEAS<x>:SOURCE<x>:HILow:TRACK:LOW:VALue	252
MEASUrement:MEAS<x>:SOURCE<x>:HILow?	253
MEASUrement:MEAS<x>:SOURCE<x>:WFM	253
MEASUrement:MEAS<x>:SOURCE<x>:WFMDB:SIGType	254
MEASUrement:MEAS<x>:SOURCE<x>:WFMDB:STATE	255
MEASUrement:MEAS<x>:STATE	256
MEASUrement:MEAS<x>:STATIstics:CLEAr	257
MEASUrement:MEAS<x>:STDdev?	258
MEASUrement:MEAS<x>:TYPE	258
MEASUrement:MEAS<x>:UNITs?	263
MEASUrement:MEAS<x>:VALue?	264
MEASUrement:STATIstics:ENABle	265
MEASUrement:STATIstics:WEIGHTing	266

MEASUrement?	266
RECALL:SETUp	267
RECALL:WAVEform	268
REF<x>:POSition	268
REF<x>:SCAle	269
REF<x>:WFMLabel	270
SAVe:SETUp	270
SAVe:WAVEform	271
SElect:CH<x>	272
SElect:CONTROL	273
SElect:MATH<x>	274
SElect:REF<x>	275
SElect?	276
SET?	276
SOURCE<x>	277
SYNC:TIMEOUT	277
SYSTem:PROPerties:ACQHWver?	279
SYSTem:PROPerties:CH<x>:BANDwidth?	279
SYSTem:PROPerties:CH<x>:CAPacitance?	280
SYSTem:PROPerties:CH<x>:CLKRec?	280
SYSTem:PROPerties:CH<x>:DYNamic?	280
SYSTem:PROPerties:CH<x>:EXTender?	281
SYSTem:PROPerties:CH<x>:FILTer?	281
SYSTem:PROPerties:CH<x>:IMPedance?	281
SYSTem:PROPerties:CH<X>:MODEInum?	282
SYSTem:PROPerties:CH<x>:NONDestruct?	282
SYSTem:PROPerties:CH<x>:OPERating?	282
SYSTem:PROPerties:CH<x>:PRObe:DYNamic?	283
SYSTem:PROPerties:CH<x>:PRObe:IMPedance?	283
SYSTem:PROPerties:CH<x>:PRObe:MODEInum?	284
SYSTem:PROPerties:CH<x>:PRObe:SCAle?	284
SYSTem:PROPerties:CH<x>:PRObe:SERialnum?	284
SYSTem:PROPerties:CH<x>:RISetime?	285
SYSTem:PROPerties:CH<x>:SERialnum?	285
SYSTem:PROPerties:CH<x>:TEKPDriver?	285
SYSTem:PROPerties:CH<x>:TEKPVersion?	286
SYSTem:PROPerties:CH<x>:WLENgth?	286
SYSTem:PROPerties:GROup<x>:TEKPVersion?	286
SYSTem:PROPerties:MAInframe:MODEInum?	287
SYSTem:PROPerties:MAInframe:SERialnum?	287
SYSTem:PROPerties:MAInframe:SWVersion?	287
SYSTem:PROPerties:ONTime?	288
SYSTem:PROPerties:POWerups?	288
SYSTem:PROPerties:PROCHWver?	288
SYSTem:PROPerties:TOTALontime?	289
TDR:CH<x>:PRESET	289
TDR:CH<x>:STEP:DESkew	290
TDR:CH<x>:STEP:POLarity	290
TDR:CH<x>:STEP:STATE	291
TDR:CH<x>:UNIts	292
TDR:INTRate	293
TDR?	293
TIME	294
TRIGger:CH<x>:CLKRec:LIST?	295
TRIGger:CH<x>:CLKRec:VALue	295
TRIGger:CLKRec:SOUrce	297
TRIGger:GATEd	298

TRIGger:HFreq.....	299
TRIGger:HOLDoff.....	300
TRIGger:INTRate.....	301
TRIGger:LEVel.....	302
TRIGger:METAReject.....	303
TRIGger:MODE.....	304
TRIGger:SETLevel.....	304
TRIGger:SLOpe.....	305
TRIGger:SOURce.....	306
TRIGger:STATE?.....	307
TRIGger?.....	307
UNLock.....	308
VERBose.....	308
WAVFrm?.....	309
WFMDB:DISPlay:EMPHasis.....	310
WFMDB:DISPlay:GRADing.....	311
WFMDB:DISPlay:INVert.....	311
WFMDB:DISPlay?.....	312
WFMDB:WFMDB<x>:CLEAR.....	312
WFMDB:WFMDB<x>:DISPlay.....	313
WFMDB:WFMDB<x>:ENABLE.....	314
WFMDB:WFMDB<x>:SOURce.....	314
WFMDB:WFMDB<x>?.....	315
WFMDB?.....	316
WFMInpre:BIT_Nr?.....	316
WFMInpre:BN_Fmt.....	316
WFMInpre:BYT_Nr?.....	317
WFMInpre:BYT_Or.....	318
WFMInpre:ENCdg.....	318
WFMInpre:NR_Pt.....	319
WFMInpre:PT_Fmt.....	320
WFMInpre:WFMLabel.....	320
WFMInpre:XINcr.....	321
WFMInpre:XMULT.....	322
WFMInpre:XOff.....	322
WFMInpre:XUNit.....	323
WFMInpre:XZEro.....	323
WFMInpre:YMUlt.....	324
WFMInpre:YOff.....	325
WFMInpre:YSCALE.....	325
WFMInpre:YUNit.....	326
WFMInpre:YZEro.....	326
WFMInpre?.....	327
WFMOutpre:BIT_Nr?.....	327
WFMOutpre:BN_FMT.....	328
WFMOutpre:BYT_Nr?.....	328
WFMOutpre:BYT_Or.....	329
WFMOutpre:ENCdg.....	329
WFMOutpre:NR_Pt?.....	330
WFMOutpre:PT_Fmt?.....	331
WFMOutpre:WFId?.....	331
WFMOutpre:WFMLabel?.....	331
WFMOutpre:XINcr?.....	332
WFMOutpre:XMUIt?.....	332
WFMOutpre:XOff?.....	332
WFMOutpre:XUNit?.....	333
WFMOutpre:XZEro?.....	333

WFMOupre:YMUIt?	334
WFMOupre:YOFf?.....	334
WFMOupre:YSCALE?.....	334
WFMOupre:YUNit?.....	335
WFMOupre:YZEro?.....	335
WFMOupre?	336
Status and Events	337
Registers	337
Queues	340
Event Handling Sequence.....	341
Synchronization Methods	342
Messages	347
Miscellaneous	355
Reserved Words.....	355
Factory Default Setup Values.....	358
 GPIB Interface Specifications	365
GPIB Functions	365
Interface Messages	367
Programming Examples	368
Descriptions of the Sample Programs.....	368
To Run the Sample Programs.....	368
To Copy the Sample-Program Code to Your Programs.....	369
Index	370

Preface

Copyright and Version Information

Copyright © Tektronix, Inc. All rights reserved. Licensed software products are owned by Tektronix or its suppliers and are protected by United States copyright laws and international treaty provisions.

Use, duplication or disclosure by the Government is subject to restrictions as set forth in subparagraph (c)(1)(ii) of the Rights in Technical Data and Computer Software clause at DFARS 252.227-7013, or subparagraphs (c)(1) and (2) of the Commercial Computer Software – Restricted Rights clause at FAR 52.227-19, as applicable.

Tektronix products are covered by U.S. and foreign patents, issued and pending. Information in this documentation supercedes that in all previously published material. Specifications and price change privileges reserved.

Tektronix, Inc. P.O. Box 500, Beaverton, OR 97077

TEKTRONIX, TEK, TEKPROBE, and FrameScan are registered trademarks of Tektronix, Inc.

Getting Started

Introduction

This online programmer guide provides you with the information you need to use GPIB commands to remotely control your instrument. With this information, you can write computer programs that will perform functions such as setting the front-panel controls, taking measurements, performing statistical calculations, and exporting data for use in other programs, such as spreadsheets.

The programmer guide is divided into the following major topics (books):

- **Getting Started.** This topic introduces you to the online programmer guide and provides basic information about setting up your instrument for remote control.
- **Command Syntax.** This topic provides an overview of the command syntax that you will use to communicate with the instrument and other general information about commands, such as how commands and queries are constructed, and how to enter commands, constructed mnemonics, and argument types.
- **Command Groups.** This topic contains all the commands listed in functional groups. Each group consists of an overview of the commands in that group and a table that lists all the commands and queries for that group. You can click a command in the listing and a detailed description of the command will be displayed.
- **Status and Events.** This topic discusses the status and event reporting system for the GPIB interface. This system informs you of certain significant events that occur within the instrument. Topics that are discussed include registers, queues, event-handling sequences, synchronization methods, and messages that the instrument may return, including error messages.
- **Miscellaneous.** This topic contains miscellaneous information, such as a list of reserved words, a table of the factory initialization (default) settings, and the GPIB interface specifications, that may be helpful when using GPIB commands to remotely control the instrument.

Remote Communications

Before setting up your instrument for remote communications, you should familiarize yourself with the following GPIB requirements:

- A unique device address must be assigned to each device on the bus. No two devices can share the same device address.
- No more than 15 devices can be connected to any one line.

- One device should be connected for every 6 feet (2 meters) of cable used.
- No more than 65 feet (20 meters) of cable should be used to connect devices to a bus.
- At least two-thirds of the devices on the network should be powered on while using the network.
- Connect the devices on the network in a star or linear configuration. Do not use loop or parallel configurations.

Connecting to the Instrument

Your instrument has a 24-pin GPIB connector on its rear panel. This connector has a D-type shell and conforms to IEEE Std 488.1–1987. Attach an IEEE Std 488.1–1987 GPIB cable to this connector and to your controller as shown in the following figure.

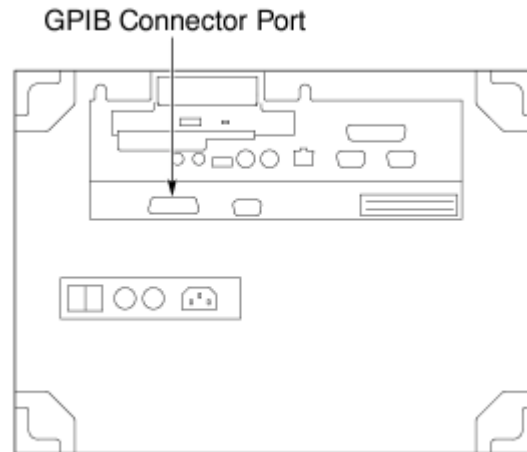

If necessary, the GPIB connectors can be stacked as shown in the figure below.

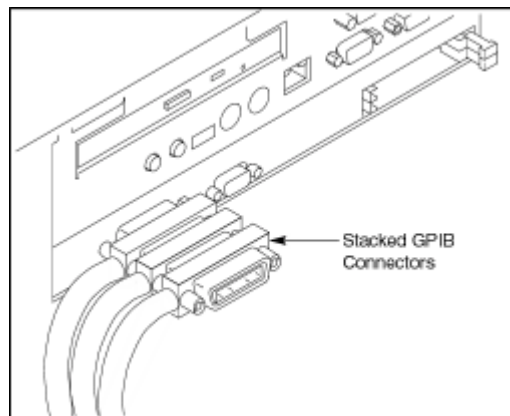

Setting the GPIB Address

To function correctly, your instrument must have a unique device address. The default settings for the GPIB configuration are:

- GPIB Address 1
- GPIB Mode GPIB Talk/Listen

To change either of the GPIB settings, do the following:

1. Select User Preferences... from the Utilities menu.

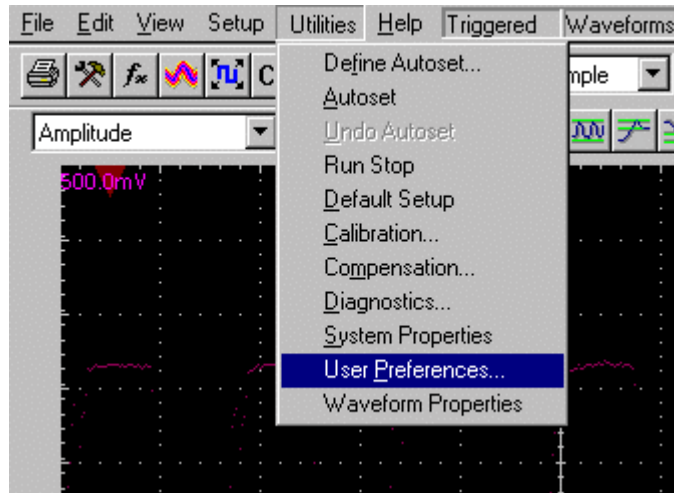

2. Select the GPIB Configuration Tab.

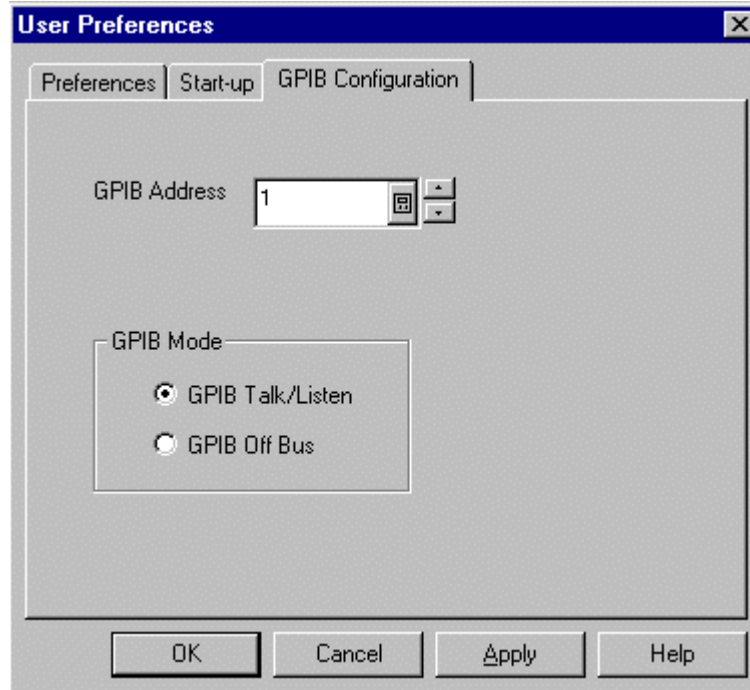

3. Change the GPIB Address to a unique address.
4. Click OK.

The instrument is set up for bi-directional communication with your controller.

Documentation

In addition to this *CSA8000 & TDS8000 Programmer Online Guide*, the following documentation is included with this instrument.



CSA8000 & TDS8000 Online Help. This online help system is integrated with the User Interface application that ships with this product.

CSA8000B & TDS8000B User Manual or CSA8000 & TDS8000 User Manual. This is the user manual for the instrument and is included with it.

CSA8000B & TDS8000B Reference or CSA8000 & TDS8000 Reference. This is a quick reference to the major features of the instrument and how they operate. The reference is included with the instrument.

80E00 Series Electrical Sampling Module User Manual. This user manual is included as a standard accessory with electrical sampling modules ordered for use with this instrument.

80C00 Series Optical Sampling Module User Manual. This user manual is included as a standard accessory with optical sampling modules ordered for use with this instrument.

Oscilloscope Analysis and Connectivity Made Easy. This book explores some options for getting data from your instrument into any one of several available analysis tools. See the CSA8000 & TDS8000 Online Help described above for more information.

Note: Occasionally, Tektronix publishes user information on its web site, such as updated drivers, application notes, and programming examples. See *Contacting Tektronix* in your user manual for access information on this site.

Command Syntax

Syntax Overview

You can control the operations and functions of the instrument through the GPIB interface using commands and queries. The related topics listed below describe the syntax of these commands and queries. The topics also describe the conventions that the instrument uses to process them. See the *Command Groups* topic in the table of contents to locate lists of the commands by command group. The table of contents also lists the commands alphabetically, or you can use the index to locate a specific command.

Backus-Naur Form Notation

This documentation describes the commands and queries using Backus-Naur Form (BNF) notation. Refer to the following table for the symbols that are used.

Symbols for Backus-Naur Form	
Symbol	Meaning
< >	Defined element
::=	Is defined as
	Exclusive OR
{ }	Group; one element is required
[]	Optional; can be omitted
...	Previous element(s) may be repeated
()	Comment

Related Topics:

- Command and Query Structure
- Clearing the Instrument
- Command Entry
- Constructed Mnemonics
- Argument Types

Command and Query Structure

Overview

Commands consist of set commands and query commands (usually called commands and queries). Commands modify instrument settings or tell the instrument to perform a specific action. Queries cause the instrument to return data and information about its status.

Most commands have both a set form and a query form. The query form of the command differs from the set form by its question mark on the end. For example, the set command ACQUIRE:MODE has a query form ACQUIRE:MODE?. Not all commands have both a set and a query form. Some commands have set only and some have query only.

Messages

A command message is a command or query name followed by any information the instrument needs to execute the command or query. Command messages may contain five element types, defined in the following table.

Command Message Elements	
Symbol	Meaning
<Header>	This is the basic command name. If the header ends with a question mark, the command is a query. The header may begin with a colon (:) character. If the command is concatenated with other commands, the beginning colon is required. Never use the beginning colon with command headers beginning with a star (*).
<Mnemonic>	This is a header subfunction. Some command headers have only one mnemonic. If a command header has multiple mnemonics, a colon (:) character always separates them from each other.
<Argument>	This is a quantity, quality, restriction, or limit associated with the header. Some commands have no arguments while others have multiple arguments. A <space> separates arguments from the header. A <comma> separates arguments from each other.
<Comma>	A single comma is used between arguments of multiple-argument commands. Optionally, there may be white space characters before and after the comma.
<Space>	A white space character is used between a command header and its argument. Optionally, a white space may consist of multiple white space characters.

Commands

Commands cause the instrument to perform a specific function or change one of its settings. Commands have the structure:

```
[ : ] <Header> [ <Space> <Argument> [ <Comma> <Argument> ] . . . ]
```

A command header consists of one or more mnemonics arranged in a hierarchical or tree structure. The first mnemonic is the base or root of the tree and each subsequent mnemonic is a level or branch off the previous one. Commands at a higher level in the tree may affect those at a lower level. The leading colon (:) always returns you to the base of the command tree.

Queries

Queries cause the instrument to return information about its status or settings. Queries have the structure:

- [:]<Header>?
- [:]<Header>? [<Space><Argument> [<Comma><Argument>] ...]

You can specify a query command at any level within the command tree unless otherwise noted. These branch queries return information about all the mnemonics below the specified branch or level. For example, HISTogram:STATistics:STDdev? returns the standard deviation of the histogram, while HISTogram:STATistics? returns all the histogram statistics, and HISTogram? returns all the histogram parameters.

Headers

You can control whether the instrument returns headers as part of the query response. Use the HEADer command to control this feature. If header is on, the query response returns command headers and formats itself as a valid set command. When the header is off, the response includes only the values. This may make it easier to parse and extract the information from the response. The table below shows the difference in responses.

Comparison of Header Off and Header On Responses		
Query	Header Off	Header On
TIME?	"14:30:00"	:TIME "14:30:00"
ACQuire:NUMAVg?	100	:ACQUIRE:NUMAVG 100

Clearing the Instrument

You can clear the Output Queue and reset the instrument to accept a new command or query by using the selected Device Clear (DCL) GPIB function. Refer to your GPIB library documentation for further details about the selected Device Clear operation.

Command Entry

Rules

The following rules apply when entering commands:

- You can enter commands in upper or lower case.
- You can precede any command with white space characters. White space characters include any combination of the ASCII control characters 00 through 09 and 0B through 20 hexadecimal (0 through 9 and 11 through 32 decimal).
- The instrument ignores commands consisting of any combination of white space characters and line feeds.

Abbreviating

You can abbreviate many instrument commands. Each command in this documentation shows the abbreviations in capitals. For example, you can enter the command `ACQUIRE:NUMAVg` simply as `ACQ:NUMA` or `acq:numa`.

Abbreviation rules may change over time as new instrument models are introduced. Thus, for the most robust code, use the full spelling.

If you use the `HEADER` command to have command headers included as part of query responses, you can further control whether the returned headers are abbreviated or are full-length with the `VERBOSE` command.

Concatenating

You can concatenate any combination of set commands and queries using a semicolon (;). The instrument executes concatenated commands in the order received.

When concatenating commands and queries, you must follow these rules:

- Separate completely different headers by a semicolon and by the beginning colon on all commands except the first one. For example, the commands, `TRIGGER:MODE NORMAL` and `ACQUIRE:NUMAVg 10`, can be concatenated into the following single command:
`TRIGGER:MODE NORMAL;:ACQUIRE:NUMAVg 10`
- If concatenated commands have headers that differ by only the last mnemonic, you can abbreviate the second command and eliminate the beginning colon. For example, you can concatenate the commands `ACQUIRE:MODE ENVELOPE` and `ACQUIRE:NUMAVg 10` into a single command:
`ACQUIRE:MODE ENVELOPE; NUMAVg 10`
The longer version works equally well:
`ACQUIRE:MODE ENVELOPE;:ACQUIRE:NUMAVg 10`
- Never precede a star (*) command with a colon:
`ACQUIRE:MODE ENVELOPE;*OPC`
Any commands that follow will be processed as if the star command was not there. For example, the `ACQUIRE:MODE ENVELOPE;*OPC;NUMAVg 10` commands will set the acquisition mode to envelope and set the number of acquisitions for averaging to 10.
- When you concatenate queries, the responses to all the queries are concatenated into a single response message. For example, if the display background color is white and the display foreground color is black, the concatenated query `DISPLAY:COLOR:BACKGROUND?;FOREGROUND?` will return the following:
If the header is on:
`:DISPLAY:COLOR:BACKGROUND 7;`
`:DISPLAY:COLOR:FOREGROUND 0`
If the header is off:

7;0

- Set commands and queries may be concatenated in the same message. For example, `ACQuire:MODE SAMple;NUMAVg?;STATE?` is a valid message that sets the acquisition mode to sample. The message then queries the number of acquisitions for averaging and the acquisition state. Concatenated commands and queries are executed in the order received.

Here are some invalid concatenations:

- `DISPlay:STYle:NORMal;ACQuire:NUMAVg 10`
(no colon before `ACQuire`)
- `DISPlay:COLor:CURSor1 1;;CURSor2 5`
(extra colon before `CURSor2`; use `DISPlay:COLor:CURSor1 1;CURSor2 5` instead)
- `DISPlay:STYle:NORMal;:*OPC`
(colon before a star (*) command)
- `DISPlay:COLor:CURSor1 1;COLor:CURSor2 5`
(levels of the mnemonics are different; either remove the second use of `COLor` or place `:DISPlay:` in front of `COLor:CURSor2 5`)

Terminating

This documentation uses `<EOM>` (End of message) to represent a message terminator.

End of Message Terminator	
Symbol	Meaning
<code><EOM></code>	Message terminator

The end-of-message terminator may be the `END` message (EOI asserted concurrently with the last data byte), the ASCII code for line feed (LF) sent as the last data byte, or both. The instrument always terminates messages with LF and EOI. It allows white space before the terminator. For example, it allows `CR LF`.

Constructed Mnemonics

Some header mnemonics specify one of a range of mnemonics. For example, a channel mnemonic can be `CH1`, `CH2`, `CH3`, ... through `CH8`. You use these mnemonics in the command just as you do any other mnemonic. For example, there is a `CH1:POSition` command, and there is also a `CH2:POSition` command. In the command descriptions, this list of choices is abbreviated as `CH<x>`.

Cursor Position Mnemonics

When cursors are displayed, commands may specify which cursor of the pair to use.

Cursor Mnemonics	
Symbol	Meaning
CURSOR<x>	A cursor selector; <x> is either 1 or 2.
POSITION<x>	A cursor selector; <x> is either 1 or 2.
HPOS<x>	A cursor selector; <x> is either 1 or 2.

Histogram Statistics Specifier Mnemonics

Commands can specify which Sigma value to return for histogram statistics as a mnemonic in the header. A Sigma is specified in this way:

Histogram Statistics Specifier Mnemonics	
Symbol	Meaning
SIGMA<x>	A histogram statistics specifier; <x> is 1, 2, or 3.

Magnified Timebase Specifier Mnemonics

Commands can specify which of two magnified timebases to set or query as a mnemonic in the header. The magnified timebases are specified in this way:

Magnified Timebase Specifier Mnemonics	
Symbol	Meaning
MAG<x>	A magnified timebase specifier; <x> is 1 or 2.

Mask Specifier Mnemonics

Commands can specify which mask to set or query as a mnemonic in the header. The masks are specified in this way:

Mask Specifier Mnemonics	
Symbol	Meaning
MASK<x>	A mask specifier; <x> is 1 through 8.

Measurement Specifier Mnemonics

Commands can specify which measurement to set or query as a mnemonic in the header. Up to eight automated measurements may be displayed with each displayed waveform. The displayed measurements are specified in this way:

Measurement Specifier Mnemonics	
Symbol	Meaning
MEAS<x>	A measurement specifier; <x> is 1 through 8.
SOURCE<x>	A waveform specifier; <x> is either 1 (Source 1 waveform) or 2 (Source 2 waveform).
REFLevel<x>	A waveform specifier for reference level measurements; <x> is either 1 (Source 1 waveform) or 2 (Source 2 waveform).

Channel Mnemonics

Commands specify the channel to use as a mnemonic in the header.

Channel Mnemonics	
Symbol	Meaning
CH<x>	A channel specifier; <x> is 1 through 8.

Math Waveform Mnemonics

Commands can specify the mathematical waveform to use as a mnemonic in the header.

Math Waveform Mnemonics	
Symbol	Meaning
MATH<x>	A math waveform specifier; <x> is 1 through 8.

Reference Waveform Mnemonics

Commands can specify the reference waveform to use as a mnemonic in the header.

Reference Waveform Mnemonics	
Symbol	Meaning
REF <x>	A reference waveform specifier; <x> is 1 through 8.

Waveform Database Mnemonics

In some commands, you can specify a waveform database as follows:

Waveform Database Mnemonics	
Symbol	Meaning
WFMDB<x>	A waveform database specifier; <x> is either 1 or 2.

Argument Types

Numeric

Many instrument commands require numeric arguments. The syntax shows the format that the instrument returns in response to a query. This is also the preferred format when sending the command to the instrument, although any of the formats will be accepted. This documentation represents these arguments as follows:

Numeric Arguments	
Symbol	Meaning
<NR1>	Signed integer value
<NR2>	Floating point value without an exponent
<NR3>	Floating point value with an exponent

Most numeric arguments will be automatically forced to a valid setting, by either rounding or truncating, when an invalid number is input (unless otherwise noted in the command description).

Quoted String

Some commands accept or return data in the form of a quoted string, which is simply a group of ASCII characters enclosed by a single quote (') or double quote ("). For example: "this is a quoted string". This documentation represents these arguments as follows:

Quoted String Argument	
Symbol	Meaning
<QString>	Quoted string of ASCII text

A quoted string can include any character defined in the 7-bit ASCII character set. Follow these rules when you use quoted strings:

- Use the same type of quote character to open and close the string. For example: "this is a valid string".
- You can mix quotation marks within a string as long as you follow the previous rule. For example, "this is an 'acceptable' string".
- You can include a quote character within a string simply by repeating the quote. For example: "here is a "" mark".
- Strings can have upper or lower case characters.
- If you use a GPIB network, you cannot terminate a quoted string with the END message before the closing delimiter.
- A carriage return or line feed imbedded in a quoted string does not terminate the string, but is treated as just another character in the string.
- The maximum length of a quoted string returned from a query is 1000 characters.

Here are some invalid strings:

- "Invalid string argument' (quotes are not of the same type)
- "test<EOI>" (termination character is embedded in the string)

Block

Several instrument commands use a block argument form (see the following table).

Block Arguments	
Symbol	Meaning
<NZDig>	A nonzero digit character in the range of 1–9
<Dig>	A digit character, in the range of 0–9
<DChar>	A character with the hexadecimal equivalent of 00 through FF (0 through 255 decimal)
<Block>	A block of data bytes defined as: <Block> ::= {#<NZDig><Dig>[<Dig>...][<DChar>...] [#0[<DChar>...]<terminator>}]

<NZDig> specifies the number of <Dig> elements that follow. Taken together, the <Dig> elements form a decimal integer that specifies how many <DChar> elements follow.

Command Groups

Acquisition Command Group

Overview

You use the commands in the Acquisition Command Group to set up the modes and functions that control how the instrument acquires the signals you input to its channels and processes them into waveforms.

Using these commands for acquiring waveforms, you can do the following:

- Start and stop acquisitions.
- Control whether each waveform is simply acquired, averaged or enveloped over successive acquisitions of that waveform.
- Set the controls or conditions that start and stop acquisitions.
- Determine the action the system takes upon completing an acquisition, such as saving all waveforms and sounding a bell when the acquisition is stopped.
- Get data on acquired waveforms, histograms, and masks.
- Get acquisition parameters.
- Clear all acquired data.

Command Description

Command	Description
ACQUIRE:CURRENTCOUNT:ACQWFMS?	Returns acquired waveforms count
ACQUIRE:CURRENTCOUNT:HISTHITS?	Returns histogram hits count
ACQUIRE:CURRENTCOUNT:HISTWFMS?	Returns histogram waveforms count
ACQUIRE:CURRENTCOUNT:MASKHITS<x>?	Returns mask<x> hits count
ACQUIRE:CURRENTCOUNT:MASKSAMPLES?	Returns mask samples count
ACQUIRE:CURRENTCOUNT:MASKTHITS?	Returns total mask hits count
ACQUIRE:CURRENTCOUNT:MASKWFMS?	Returns mask waveforms count
ACQUIRE:DATA:CLEAR	Clears all acquired data
ACQUIRE:MODE	Sets acquisition mode
ACQUIRE:MODE?	Returns acquisition mode
ACQUIRE:NUMAVG	Sets number of acquisitions for average
ACQUIRE:NUMAVG?	Returns number of acquisitions for average
ACQUIRE:SAVEFILE:SAVESCREEN	Sets file to save screen to on acquisition stopped
ACQUIRE:SAVEFILE:SAVESCREEN?	Returns file to save screen to on acquisition stopped
ACQUIRE:SAVEFILE:SAVEWFM	Sets file to save waveform data to on acquisition stopped
ACQUIRE:SAVEFILE:SAVEWFM?	Returns file to save waveform data to on acquisition stopped

	data to on acquisition stopped
ACQuire:STATE	Starts or stops acquisitions
ACQuire:STATE?	Returns acquisition state
ACQuire:STOPAfter:ACTion	Sets stop after action
ACQuire:STOPAfter:ACTion?	Returns stop after action
ACQuire:STOPAfter:BELL	Sets whether to sound bell on acquisition stopped
ACQuire:STOPAfter:BELL?	Returns whether to sound bell on acquisition stopped
ACQuire:STOPAfter:CONDition	Sets acquisition stopafter condition
ACQuire:STOPAfter:CONDition?	Returns acquisition stopafter condition
ACQuire:STOPAfter:COUNt	Sets the stopafter count value
ACQuire:STOPAfter:COUNt?	Returns stopafter count value, which is dependent on the condition set by the ACQuire:STOPAfter:CONDition command
ACQuire:STOPAfter:MODE	Sets stopafter mode
ACQuire:STOPAfter:MODE?	Returns stopafter mode
ACQuire:STOPAfter?	Returns all stopafter parameters
ACQuire?	Returns acquisition parameters

Calibration Command Group

Overview

The calibration commands provide information about the current state of the calibration for the mainframe and all resident sampling-module channels. Additional commands allow you to update portions of the "electronic calibration sticker" information, to check the protection status of the calibration information, and to set or query the front-panel DC calibration output.

Command Descriptions

Command	Description
CALibrate:DATE:CH<x>?	Returns date and time of the last sampling module channel calibration
CALibrate:DATE:MAInframe?	Returns the date and time of the last mainframe calibration
CALibrate:DCCALibrator	Sets the value of the DC Calibrator voltage
CALibrate:DCCALibrator?	Returns the value of the DC Calibrator voltage
CALibrate:HOSTInfo:CH<x>?	Returns the mainframe model number, serial number, and mainframe channel in which the sampling module channel was located during the last calibration information update.
CALibrate:LOCK:STATus?	Returns the status of the calibration information hardware lock switch
CALibrate:STATus:CH<x>?	Returns calibration status for specified sampling module channel
CALibrate:STATus:MAInframe?	Returns calibration status for mainframe
CALibrate:TEMPerature:CH<x>?	Returns the difference in °C between the current sampling module channel temperature and the temperature recorded at the last calibration

	information update
CALibrate:TEMPerature:MAInframe?	Returns the difference in °C between the current mainframe temperature and the temperature recorded at the last calibration information update
CALibrate:UPDATEinfo:ALL	Updates date, time, temp and (for sampling modules) host mainframe information
CALibrate:UPDATEinfo:CH<x>	Updates the calibration information in the nonvolatile memory of the sampling module channel
CALibrate:UPDATEinfo:MAInframe	Updates the calibration information in the nonvolatile memory of the mainframe

Compensation Command Group

Overview

The compensation commands provide information about the current state of the compensation for the mainframe and all resident sampling-module channels, means to invoke compensation functions, and management of compensation storage memory locations.

There are two nonvolatile compensation storage memory blocks in the mainframe and each sampling module channel: Factory and User. In addition, there is a volatile run-time, in-use version of all compensation data, which is the compensation data actually used during the operation of the instrument.

Command Descriptions

Command	Description
COMPensate:ALL	Compensates the mainframe and all resident sampling modules
COMPensate:CH<x>	Compensates the sampling module channel for DC variances
COMPensate:DARKLev:CH<x>	Compensates the specified optical channel by removing residual DC offsets in the entire vertical path
COMPensate:DATE:CH<x>?	Returns date and time of the current in-use compensation data for the sampling module channel
COMPensate:DATE:MAInframe?	Returns date and time of the current in-use compensation data for the mainframe
COMPensate:MAInframe	Compensates the mainframe for DC variances
COMPensate:OPTGAIN:CH<x>	Compensates optical user wavelength gain (wavelengths and input power)
COMPensate:RECALL:FACTory:ALL	Recalls compensation data for the mainframe and all resident sampling module channels from their respective nonvolatile factory memories into run-time compensation memory
COMPensate:RECALL:FACTory:CH<x>	Recalls compensation data from the nonvolatile factory memory of the sampling module into its associated run-time memory
COMPensate:RECALL:FACTory:MAInframe	Recalls compensation data from the nonvolatile factory memory in the mainframe into its associated run-

	time memory
COMPensate:RECAI:USER:ALL	Recalls compensation data for the mainframe and all resident sampling module channels from their respective nonvolatile user memories into run-time compensation memory
COMPensate:RECAI:USER:CH<x>	Recalls compensation data from the nonvolatile user memory of the sampling module into its associated run-time memory
COMPensate:RECAI:USER:MAInframe	Recalls compensation data from the nonvolatile user memory in the mainframe into its associated run-time memory
COMPensate:RESults:VERBose?	Returns results of last compensation, with a more detailed explanation than the COMPensate:RESults? query returns
COMPensate:RESults?	Returns brief explanation of the results of the last compensation
COMPensate:SAVe:USER:ALL	Saves volatile run-time compensation data for the mainframe and all resident sampling modules into their associated nonvolatile user memories
COMPensate:SAVe:USER:CH<x>	Saves volatile run-time compensation data for the sampling module channel into its nonvolatile user memory
COMPensate:SAVe:USER:MAInframe	Saves volatile run-time compensation data for the mainframe into its nonvolatile user memory
COMPensate:STATus:CH<x>?	Returns the current compensation status of the specified sampling module channel
COMPensate:STATus:MAInframe?	Returns the current compensation status of the mainframe
COMPensate:TEMPerature:CH<x>	Returns the difference in °C between the current temperature of the sampling module channel and the temperature currently residing in its in-use run-time compensation memory
COMPensate:TEMPerature:MAInframe?	Returns the difference in °C between the current mainframe temperature and the temperature currently residing in its in-use run-time compensation memory

Cursor Command Group

Overview

You use the commands in the Cursor Command Group to control the cursor display and readout. You can use these commands to control the setups for cursor 1 and cursor 2, such as waveform source for cursors, cursor position, and cursor color.

You can also use the commands to select one of the following cursor functions:

- Off. Turns off the display of all cursors.
- Vertical Bars. Displays vertical bar cursors, which provide traditional horizontal unit readouts for Cursor 1 (bar1), Cursor 2 (bar2), the delta between them, 1/delta (results in frequency when the horizontal unit is time), and delta/2 (when the unit is distance).

- Horizontal Bars. Displays horizontal bar cursors, which provide traditional vertical unit readouts for Cursor 1 (bar1), Cursor 2 (bar2), and the delta between them.
- Waveform. Displays waveform cursors, which provide horizontal and vertical unit readouts for Cursor 1 (bar1), Cursor 2 (bar2), the delta between them, and 1/delta (results in frequency when the horizontal unit is time).

Command Descriptions

Command	Description
CURSor:CURSor<x>:COLOR	Sets cursor<x> color
CURSor:CURSor<x>:COLOR?	Returns cursor<x> color
CURSor:CURSor<x>:SOUrce	Sets cursor <x> waveform source and timebase
CURSor:CURSor<x>:SOUrce?	Returns cursor<x> waveform source and timebase
CURSor:FUNcTION	Sets cursor function
CURSor:FUNcTION?	Returns cursor function
CURSor:HBArs:DELTA?	Returns hbars difference
CURSor:HBArs:POSition<x>	Sets hbars cursor<x> position
CURSor:HBArs:POSition<x>?	Returns hbars cursor<x> position
CURSor:HBArs?	Returns hbars cursor parameters
CURSor:SElect	Sets hbars selected cursor
CURSor:SElect?	Returns hbars selected cursor
CURSor:VBArS:DELTA?	Returns vbars difference
CURSor:VBArS:POSition<x>	Sets vbars cursor<x> position
CURSor:VBArS:POSition<x>?	Returns vbars cursor<x> position
CURSor:VBArS?	Returns vbar cursor parameters
CURSor:WAVeform:HDELTA?	Returns waveform horizontal difference
CURSor:WAVeform:HPOS<x>?	Returns waveform vertical value at cursor<x>
CURSor:WAVeform:POSition<x>	Sets waveform cursor<x> position
CURSor:WAVeform:POSition<x>?	Returns waveform cursor<x> position
CURSor:WAVeform:VDELTA?	Returns waveform vertical difference
CURSor:WAVeform?	Returns waveform cursor parameters
CURSor?	Returns all cursor parameters

Display Control Command Group

Overview

You use the commands in the Display Control Command Group to change the graticule style, the displayed intensities, and to set the characteristics of the waveform display.

You can set the following:

- Background color (default is black) and foreground color (default is silver).
- Cursor, histogram, mask, and measurement annotation colors.

- Whether cursor, histogram, mask, and measurement readouts are displayed.
- Whether measurement annotations are displayed.
- Whether waveforms are simply displayed in Normal mode as dots or vectors, in Variable Persistence mode, or in Infinite Persistence mode.
- Whether the instrument uses interpolation to increase sample density of waveform for record lengths less than 500 points, and, if interpolation is used, which type (Sin(x) or Linear).
- The style of graticule that underlies the waveforms.

Use the commands to set the style that best displays your waveforms and graticule display properties. The mode you choose globally affects all displayed waveforms; for example, you cannot set channel 1 to display in Normal mode and channel 2 in Variable Persistence mode.

There are four graticule settings:

- Frame
- Grid
- Cross Hair
- Full

Choose Frame or Grid for minimum clutter on screen; choose Full or Crosshair for ease in taking graticule measurements.

Command Descriptions

Command	Description
DISplay:COLor:BACKground	Sets graticule background color
DISplay:COLor:BACKground?	Returns graticule background color
DISplay:COLor:CURLSOR<x>	Sets cursor<x> color
DISplay:COLor:CURLSOR<x>?	Returns cursor<x> color
DISplay:COLor:FOREground	Sets graticule foreground color
DISplay:COLor:FOREground?	Returns graticule foreground color
DISplay:COLor:HIStogram	Sets histogram rectangle and plot color
DISplay:COLor:HIStogram?	Returns histogram rectangle and plot color
DISplay:COLor:MASK	Sets mask color
DISplay:COLor:MASK?	Returns mask color
DISplay:COLor?	Returns all color settings (query only)
DISplay:CURLSReadout	Sets the display state of the cursor readout
DISplay:CURLSReadout?	Returns the display state of the cursor readout
DISplay:GRATICule:HDIVS?	Returns number of horizontal divisions in graticule (query only)
DISplay:GRATICule:STYLE	Sets graticule style
DISplay:GRATICule:STYLE?	Returns graticule style
DISplay:GRATICule:VDIVS?	Returns number of vertical divisions in graticule (query only)

DISplay:GRAticule?	Returns all graticule parameters (query only)
DISplay:HISTReadout	Sets the display state of the histogram readout
DISplay:HISTReadout?	Returns the display state of the histogram readout
DISplay:INTERPolat	Sets display interpolation type
DISplay:INTERPolat?	Returns display interpolation type
DISplay:MASKReadout	Sets the display state of the mask readout
DISplay:MASKReadout?	Returns the display state of the mask readout
DISplay:MEASBar	Sets the display state of the measurement bar
DISplay:MEASBar?	Returns the display state of the measurement bar
DISplay:MEASReadout	Sets the display state of the measurement readout
DISplay:MEASReadout?	Returns the display state of the measurement readout
DISplay:PERSistence	Sets display persistence time
DISplay:PERSistence?	Returns display persistence time
DISplay:SHOWVector	Enables/Disables show vector status
DISplay:SHOWVector?	Returns display show vector status
DISplay:STYLE	Sets display persistence style (off, infinite, or variable)
DISplay:STYLE?	Returns display persistence style (off, infinite, or variable)
DISplay:WFMReadout	Sets the display state of the waveform readout
DISplay:WFMReadout?	Returns the display state of the waveform readout
DISplay?	Returns all display parameters (query only)

Hard Copy Command Group

Overview

Hard copy commands allow you to make hard copies of your data file or send hard copy data in various formats to a specified file.

Command Descriptions

Command	Description
HARDCopy	Initiates a screen copy that is sent to the controller where it is redirected to a printing device.
HARDCopy:FILENAME	Selects (and creates as needed) a file and immediately initiates a screen copy, sending it to that file. The file is saved in the format specified by the HARDCopy:FORMat command.
HARDCopy:INKSaver	Sets Ink-saver mode on or off. Ink-saver mode can conserve ink and improve print quality when printing images of waveform displays.
HARDCopy:FORMat	Selects the file format when sending a hardcopy to a file using the HARDCopy:FILENAME command.

Histogram Command Group

Overview

Histogram commands let you select the type of histogram, what part of the waveform should go into the histogram, and histogram statistics. You can use commands from this group to do the following:

- Select any channel, math, or reference waveform and create a histogram of vertical or horizontal values for it.
- Adjust the limits of the box that define the area on the waveform from which the histogram data is obtained. The histogram box can be set using source waveform coordinates or percentage-of-display coordinates.
- Create a linear or logarithmic plot of histogram data and set plot size and color.
- Clear histogram count and restart.
- Turn the display of the histogram on or off.
- Enable or disable histogram calculations.
- Get histogram statistics, such as total hits, mean value, peak-to-peak value, and standard deviation.
- Get all the histogram parameters.

Command Descriptions

Command	Description
HIStogram:BOX	Sets the left, top, right, and bottom positions of the histogram box, in source waveform coordinates
HIStogram:BOX?	Returns the left, top, right, and bottom positions of the histogram box, in source waveform coordinates
HIStogram:BOXPcnt	Sets same as HIStogram:BOX, but in percentage coordinates, with 0,0 upper left and 100,100 lower right
HIStogram:BOXPcnt?	Returns same as HIStogram:BOX, but in percentage coordinates, with 0,0 upper left and 100,100 lower right
HIStogram:COLOR	Sets histogram color
HIStogram:COLOR?	Returns histogram color
HIStogram:COUNT	Clears histogram count source data and restarts counting
HIStogram:DISplay	Sets whether histogram data is displayed on screen
HIStogram:DISplay?	Returns whether histogram is displayed on screen
HIStogram:ENABLE	Enables or disables histogram calculations
HIStogram:ENABLE?	Returns whether histogram calculations are enabled
HIStogram:MODE	Sets type of histogram to be done, either vertical or horizontal

HIStogram:MODe?	Returns type of histogram, either vertical or horizontal
HIStogram:SIze	Sets the width (or height) of the histogram on the screen in divisions
HIStogram:SIze?	Returns the width (or height) of the histogram on the screen in divisions
HIStogram:SOUrce	Sets source waveform and timebase (Main, Mag1, or Mag2) for histogram
HIStogram:SOUrce?	Returns source for histogram
HIStogram:STATistics:HITS?	Returns histogram total hits value
HIStogram:STATistics:MEAN?	Returns histogram mean value
HIStogram:STATistics:MEDIAN?	Returns histogram median value
HIStogram:STATistics:PEAKHits?	Returns histogram peak hits value
HIStogram:STATistics:PKTOPK?	Returns histogram peak to peak value
HIStogram:STATistics:SIGMA<x>?	Returns population density for $\pm<x>$ sigma value
HIStogram:STATistics:STDdev?	Returns histogram standard deviation value
HIStogram:STATistics:WAVeforms?	Returns number of waveforms used in histogram
HIStogram:STATistics?	Returns all histogram statistics
HIStogram:TYPE	Sets whether the histogram is displayed linearly or logarithmically
HIStogram:TYPE?	Returns whether the histogram is displayed linearly or logarithmically
HIStogram:WFMDB:STATE	Sets whether histogram counting is on a waveform database
HIStogram:WFMDB:STATE?	Returns whether histogram counting is on a waveform database
HIStogram?	Returns all histogram parameters

Horizontal Command Group

Overview

You use the commands from the Horizontal Command Group to control the timebases of the instrument. You can use these commands to do the following:

- Set the scale (time per division) of the Main, Mag1, and Mag2 timebases.
- Set the record lengths for the Main, Mag1, and Mag2 timebases.
- Get the time of first point and time of last point for the Main, Mag1, and Mag2 timebases.
- Get the sample resolution of the Main, Mag1, and Mag2 timebases.
- Set the horizontal position for the Main, Mag1, and Mag2 timebases.
- Set the horizontal reference for the Main, Mag1, and Mag2 timebases.

- Enable or disable the acquisition and display of the Mag1 and Mag2 timebases.
- Set the timebase mode.
- Set timebase units to seconds, bits, or distance.
- Set the Dielectric constant and propagation velocity.
- Select a communication standard, such as OC12, that automatically sets the associated bit rate.
- Adjust the external 10 MHz reference frequency to ensure that the timebase locks.
- Set the parameters for FrameScan mode, and turn the mode on or off.
- Get the screen resolution of the Main, Mag1, and Mag2 timebases.
- Get all the horizontal settings.

Command Descriptions

Command	Description
HORizontal:BITS:BITRate	Sets the bit rate of the timebase
HORizontal:BITS:BITRate?	Returns the bit rate of the timebase
HORizontal:BITS:STANdard	Sets a communication standard (or NONE) for the bit rate
HORizontal:BITS:STANdard?	Returns the communication standard, if any, to which the bit rate is set
HORizontal:DISTance:DIElectric	Returns the dielectric constant.
HORizontal:DISTance:PVELocity	Returns the propagation velocity.
HORizontal:EXT10MHZref:FREQ	Sets external horizontal reference
HORizontal:EXT10MHZref:FREQ?	Returns external horizontal reference
HORizontal:FRAMescan:AUTOPosition	Sets adjustment for timing skew between data input and trigger input in FrameScan acquisition mode
HORizontal:FRAMescan:AUTOPosition?	Returns adjustment for timing skew between data input and trigger input in FrameScan acquisition mode
HORizontal:FRAMescan:RESET	Resets FrameScan acquisition
HORizontal:FRAMescan:SCANBits	Sets number of bits in frame to scan in FrameScan acquisition mode
HORizontal:FRAMescan:SCANBits?	Returns number of bits in frame to scan in FrameScan acquisition mode
HORizontal:FRAMescan:STARTBit	Sets bit number of first bit scanned in FrameScan

	acquisition mode
HORizontal:FRAMescan:STARTBit?	Returns bit number of first bit scanned in FrameScan acquisition mode
HORizontal:FRAMescan:STATE	Sets FrameScan acquisition mode on or off
HORizontal:FRAMescan:STATE?	Returns FrameScan acquisition mode on or off
HORizontal:MAG<x>:POSition	Sets horizontal position for Mag<x> timebase
HORizontal:MAG<x>:POSition?	Returns horizontal position for Mag<x> timebase
HORizontal:MAG<x>:RECORDLength	Sets Mag<x> timebase record length
HORizontal:MAG<x>:RECORDLength?	Returns Mag<x> timebase record length
HORizontal:MAG<x>:REFPoint	Sets Mag<x> timebase reference point in percent
HORizontal:MAG<x>:REFPoint?	Returns Mag<x> timebase reference point in percent
HORizontal:MAG<x>:RESolution?	Returns Mag<x> timebase acquisition resolution
HORizontal:MAG<x>:SCALE	Sets Mag<x> timebase time per division
HORizontal:MAG<x>:SCALE?	Returns Mag<x> timebase time per division
HORizontal:MAG<x>:TOFPoint?	Returns Mag<x> timebase time of first point
HORizontal:MAG<x>:TOLPoint?	Returns Mag<x> timebase time of last point
HORizontal:MAG<x>:VIEW	Sets Mag<x> timebase view on or off
HORizontal:MAG<x>:VIEW?	Returns Mag<x> timebase view on or off
HORizontal:MAG<x>?	Returns all Mag<x> timebase settings
HORizontal:MAIn:POSition	Sets horizontal position for main timebase
HORizontal:MAIn:POSition?	Returns horizontal position for main timebase
HORizontal:MAIn:RECORDLength	Sets main timebase record length
HORizontal:MAIn:RECORDLength?	Returns main timebase record length
HORizontal:MAIn:REFPoint	Sets main timebase reference position in percent of record
HORizontal:MAIn:REFPoint?	Returns main timebase reference position in percent of record
HORizontal:MAIn:RESolution?	Returns main timebase acquisition resolution
HORizontal:MAIn:SCALE	Sets main timebase time per division
HORizontal:MAIn:SCALE?	Returns main timebase

	time per division
HORizontal:MAIn:TOFPoint?	Returns main timebase time of first point
HORizontal:MAIn:TOLPoint?	Returns main timebase time of last point
HORizontal:MAIn?	Return all main timebase settings
HORizontal:MATH<x>:MAG<x>:POSition?	Returns Math<x> "Acquisition" horizontal position for Mag<x> timebase
HORizontal:MATH<x>:MAG<x>:RECORDLength?	Returns Math<x> Mag<x> timebase record length
HORizontal:MATH<x>:MAG<x>:RESolution?	Returns Math<x> Mag<x> timebase acquisition resolution
HORizontal:MATH<x>:MAG<x>:SCALE?	Returns math <x> Mag<x> timebase time per division
HORizontal:MATH<x>:MAG<x>:TOFPoint?	Returns Math<x> Mag<x> timebase time of first point
HORizontal:MATH<x>:MAG<x>:TOLPoint?	Returns Math<x> Mag<x> timebase time of last point
HORizontal:MATH<x>:MAIn:POSition?	Returns math <x> horizontal position for main timebase
HORizontal:MATH<x>:MAIn:RECORDLength?	Returns math <x> main timebase record length
HORizontal:MATH<x>:MAIn:REFPoint?	Returns math <x> main timebase reference position in percent of record
HORizontal:MATH<x>:MAIn:RESolution?	Returns math <x> main timebase acquisition resolution
HORizontal:MATH<x>:MAIn:SCALE?	Returns math <x> main timebase time per division
HORizontal:MATH<x>:MAIn:TOFPoint?	Returns math <x> main timebase time of first point
HORizontal:MATH<x>:MAIn:TOLPoint?	Returns math <x> main timebase time of last point
HORizontal:REF<x>:MAG<x>:POSition?	Returns reference<x> "Acquisition" horizontal position for Mag<x> timebase
HORizontal:REF<x>:MAG<x>:RECORDLength?	Returns reference<x> Mag<x> timebase record length
HORizontal:REF<x>:MAG<x>:RESolution?	Returns reference<x> Mag<x> timebase screen resolution
HORizontal:REF<x>:MAG<x>:SCALE?	Returns reference<x> Mag<x> timebase time per division
HORizontal:REF<x>:MAG<x>:TOFPoint?	Returns ref<x> mag<x> timebase time of first point
HORizontal:REF<x>:MAG<x>:TOLPoint?	Returns ref<x> mag<x> timebase time of last point
HORizontal:REF<x>:MAIn:POSition?	Returns reference<x> "Acquisition" horizontal position for main

	timebase
HORizontal:REF<x>:MAIn:RECORDLength?	Returns reference<x> main timebase record length
HORizontal:REF<x>:MAIn:REFPoint?	Returns reference<x> main timebase reference position in percent of record
HORizontal:REF<x>:MAIn:RESolution?	Returns reference<x> main timebase screen resolution
HORizontal:REF<x>:MAIn:SCAle?	Returns reference<x> main timebase time per division
HORizontal:REF<x>:MAIn:TOFPoint?	Returns ref<x> main timebase time of first point
HORizontal:REF<x>:MAIn:TOLPoint?	Returns ref<x> main timebase time of last point
HORizontal:TBMode	Sets the timebase mode
HORizontal:TBMode?	Returns the timebase mod
HORizontal:UNIts	Sets horizontal units
HORizontal:UNIts?	Returns horizontal units
HORizontal?	Returns all horizontal settings

Mask Command Group

Overview

Mask commands control standard masks, user-defined masks, and testing against masks. A mask is a set of polygonal regions on the screen. Every vertical line on the screen intersects the polygon in zero, one, or two places, but never in more than two places. (A vertical line that intersects a vertical mask border is counted.) You have to break up more complicated polygons into two separate masks. Unlike limit testing, the inside of a mask is the region where waveform data would not normally fall. A telecommunications standard requires up to eight of these masks. Pulse standards always have two masks. Standards with eye patterns usually have three masks, but some have four.

You use the commands in the Mask Command Group to do the following:

- Specify the waveform source to test and mask to use.
- Specify whether to use, and the size of, mask margins, which allow you to shrink or expand an existing set of polygons by a specified percentage.
- Specify whether to display a readout of hits and the mask on screen. Options also exist for autosetting the incoming waveforms to match the mask you choose.
- Select industry-standard masks that support a variety of electrical and optical communication standards.

- Define and edit your own custom mask; create an entirely new mask, or use a standard mask as a starting reference, and edit it to meet your needs.
- Enable, disable, or reset the mask counts. Once you turn on mask counting, it remains on until you explicitly turn it off.
- Set the color for the mask polygon.

Command Descriptions

Command	Description
MASK:AUTOSet:MODE	Sets mask autoset mode to AUTO or MANUAL. If AUTO is set, a mask autoset will automatically be done after a standard mask is selected; if MANUAL is set, mask autoset for a standard mask runs only if the user presses the AUTOSET button or sends the AUTOSet EXECute command.
MASK:AUTOSet:MODE?	Returns whether mask autoset mode is set to AUTO or MANUAL.
MASK:COLOr	Sets mask color
MASK:COLOr?	Returns mask color
MASK:COUNT	Clear mask counts and source data, and restart counting
MASK:COUNT?	Returns all the values for the mask count parameters
MASK:COUNT:SAMPles?	Returns the total number of sample points that have gone into mask counting
MASK:COUNT:STATE	Sets mask counting on or off
MASK:COUNT:STATE?	Returns mask counting on or off
MASK:COUNT:TOTal?	Returns total number of mask hits
MASK:COUNT:WAVeforms?	Returns the total number of waveforms that have gone into mask counting
MASK:DISPlay	Sets whether or not defined masks are displayed on the screen (ON or OFF)
MASK:DISPlay?	Returns whether or not defined masks are displayed on the screen (ON or OFF)
MASK:MARgin:PERCent	Defines the mask margin in percent
MASK:MARgin:PERCent?	Returns the mask margin in percent
MASK:MARgin:STATE	Turns mask margins on or off
MASK:MARgin:STATE?	Returns the mask margin state
MASK:MASK<x>	Delete all points in mask<x>
MASK:MASK<x>?	Returns all mask<x> parameters
MASK:MASK<x>:COUNT?	Returns number of hits in mask<x>
MASK:MASK<x>:NR_Pt ?	Returns number of points in mask<x>
MASK:MASK<x>:POInts	Defines the points in a mask in waveform coordinates
MASK:MASK<x>:POInts?	Returns the points in the specified mask in waveform coordinates
MASK:MASK<x>:POINTSPnt	Define points in a mask, in percentage coordinates, with 0,0 upper left and 100,100 lower right
MASK:MASK<x>:POINTSPnt?	Return points in a mask, in percentage coordinates, with 0,0 upper left and 100,100 lower right
MASK:SOUrce	Sets which waveform and timebase will be compared against the mask(s) when counting is turned on
MASK:SOUrce?	Returns which waveform and timebase will be compared against the mask(s) when

	counting is turned on
MASK:STANdard	Selects a standard communication mask
MASK:STANdard?	Returns the current standard communication mask
MASK:WFMDB:STATE	Sets whether a waveform database is used as a source for mask counting
MASK:WFMDB:STATE?	Returns whether a waveform database is used as a source for mask counting
MASK?	Return all mask parameters

Math Command Group

Overview

You use the commands in the Math Command Group to create and define math waveforms. You can define and display up to eight math waveforms simultaneously. You use the available math functions, such as integration, differentiation, square root, and natural logs, to define your math waveform.

Math expressions can be simple, such as C1, which specifies that a waveform should show the signal source of channel 1 with no mathematical computation. Math expressions can also be complex, consisting of 100 plus characters and comprising many sources, functions, and operators.

Math expressions require at least one source waveform. When the acquisition of a live waveform stops, so does the acquisition of any math waveforms using that waveform as a source. When a live waveform update or reference waveform is altered, math waveforms containing those waveforms as sources are also updated to reflect the changes. Also, sources must exist, but do not need to be displayed to be used in and to update math waveforms.

Command Descriptions

Command	Description
MATH<x>:DEFine	Sets math<x> definition
MATH<x>:DEFine?	Returns math<x> definition
MATH<x>:FILTer:MODE	Sets the filter mode for the specified math waveform
MATH<x>:FILTer:MODE?	Returns the selected filter mode for the specified math waveform
MATH<x>:FILTer:RISetime	Sets the risetime (bandwidth) of the math filter function
MATH<x>:FILTer:RISetime?	Returns the risetime (bandwidth) of the math filter function for the specified math waveform
MATH<x>:NUMavg	Sets the number of waveforms to average for a math waveform for the specified math waveform
MATH<x>:NUMavg?	Returns the number of waveforms to average for a math waveform
MATH<x>:POSition	Sets math vertical position
MATH<x>:POSition?	Returns math vertical position
MATH<x>:SCAle	Sets math vertical scale (per div)
MATH<x>:SCAle?	Returns math vertical scale (per div)
MATH<x>:UNITs?	Returns math units

MATH<x>:WFMLabel	Sets or queries the label associated with the specified math waveform
MATH<x>?	Returns math<x> settings

Measurement Command Group

Overview

You use the commands in the Measurement Command Group to control the automated measurement system. Up to eight automated measurements can be displayed on the screen. In the commands, these eight measurement slots are named MEAS<x>, where <x> can be 1 through 8. You use the commands to do the following:

- Obtain measurement results.
- Set and query measurement parameters. You can assign most parameters differently for each source of a measurement slot.
- Select the measurement slot (1 through 8), and turn it on and off.
- Select the waveform (Source1) to be measured (or the Source1 and Source2 waveforms for delay and other two-waveform measurements).
- View the value of the currently selected measurement.
- Clear the selected measurement and its statistics.
- Select whether the measurement displays annotations (indicating which portion of the waveform is being measured as well as reference levels for that measurement) and statistics.
- Select whether or not statistics on measurements are computed.
- Perform measurements on waveform databases.
- Set the signal type for waveform database measurements (Pulse, Eye, or RZ).
- Clear the waveform database.
- Define measurement regions using gates.
- Set slope and direction for delay measurements.
- Select a tracking method (algorithm) that is used to track the high and low value of the waveform.
- Enable tracking of the high and low values of the waveform automatically, and specify a high and/or low value (when tracking is disabled).
- Select a reference level calculation method.

- Set Hi, Mid, and Low reference values, either as percentages of the high-low range or as absolute values.
- Set measurement parameters to default values.

Command Descriptions

Command	Description
MEASUrement:ALL:VALue?	Returns all measurement values
MEASUrement:ANNOtations:STATE	Sets measurement show annotations state on or off
MEASUrement:ANNOtations:STATE?	Returns measurement show annotations state
MEASUrement:LIST	Establishes a list of defined measurements for which you want values returned.
MEASUrement:LIST?	Returns a list of defined measurements (for example, MEAS1, MEAS2)
MEASUrement:LISTValue?	Returns the values of the measurements in the list created with the MEASUrement:LIST command
MEASUrement:MEAS<x>:ALL?	Returns all measurement statistics values for the measurement specified by x
MEASUrement:MEAS<x>:EYEWIndow	Sets the percent of interval between two eye crossings centered on the middle of the region
MEASUrement:MEAS<x>:EYEWIndow?	Returns the percent of interval between two eye crossings centered on the middle of the region
MEASUrement:MEAS<x>:GATing:STATE	Sets the gating state (on or off) for the measurement specified by x
MEASUrement:MEAS<x>:GATing:STATE?	Returns the gating state (on or off) for the measurement specified by x
MEASUrement:MEAS<x>:JITter	Sets jitter-level crossing for measurement
MEASUrement:MEAS<x>:JITter?	Returns jitter-level crossing for measurement
MEASUrement:MEAS<x>:MAXimum?	Returns measurement statistics maximum value for measurement <x>
MEASUrement:MEAS<x>:MEAN?	Returns measurement statistics mean value for measurement <x>
MEASUrement:MEAS<x>:MINimum?	Returns measurement statistics minimum value for measurement <x>
MEASUrement:MEAS<x>:NOISe	Sets whether noise is measured on the high or low level of the signal
MEASUrement:MEAS<x>:NOISe?	Returns whether noise is measured on the high or low level of the signal
MEASUrement:MEAS<x>:REFLevel<x>:ABSolute:HIGH	Sets the top reference level in absolute waveform units
MEASUrement:MEAS<x>:REFLevel<x>:ABSolute:HIGH?	Returns the top reference level in absolute waveform units
MEASUrement:MEAS<x>:REFLevel<x>:ABSolute:LOW	Sets the low reference level in absolute waveform units
MEASUrement:MEAS<x>:REFLevel<x>	Returns the low reference level in

:ABSolute:LOW?	absolute waveform units
MEASUrement:MEAS<x>:REFLevel<x>:ABSolute:MID	Sets the mid reference level in absolute waveform units
MEASUrement:MEAS<x>:REFLevel<x>:ABSolute:MID?	Returns the mid reference level in absolute waveform units
MEASUrement:MEAS<x>:REFLevel<x>:METHod	Sets the method to calculate reference levels, either as a % of the high-low range or in absolute vertical units
MEASUrement:MEAS<x>:REFLevel<x>:METHod?	Returns the method used to calculate reference levels, either as a % of the high-low range or in absolute vertical units
MEASUrement:MEAS<x>:REFLevel<x>:RELative:HIGH	Sets the high reference level as a % of the high-low range
MEASUrement:MEAS<x>:REFLevel<x>:RELative:HIGH?	Returns the high reference level as a % of the high-low range
MEASUrement:MEAS<x>:REFLevel<x>:RELative:LOW	Sets the low reference level as a % of the high-low range
MEASUrement:MEAS<x>:REFLevel<x>:RELative:LOW?	Returns the low reference level as a % of the high-low range
MEASUrement:MEAS<x>:REFLevel<x>:RELative:MID	Sets the mid reference level as a % of the high-low range
MEASUrement:MEAS<x>:REFLevel<x>:RELative:MID?	Returns mid reference level as a % of the high-low range
MEASUrement:MEAS<x>:REFLevel<x>?	Returns all reference level<x> settings for measurement slot <x>
MEASUrement:MEAS<x>:SETDefault	Sets all measurement values to the instrument default settings
MEASUrement:MEAS<x>:SOURCE<x>:EDGE:DIRection	Sets the direction (forward or backward) that the instrument uses to look for the rising or falling edge
MEASUrement:MEAS<x>:SOURCE<x>:EDGE:DIRection?	Returns the direction (forward or backward) that the instrument uses to look for the rising or falling edge
MEASUrement:MEAS<x>:SOURCE<x>:EDGE:SLOPe	Sets the slope of the edges used in delay time measurements
MEASUrement:MEAS<x>:SOURCE<x>:EDGE:SLOPe?	Returns the slope of the edges used in delay time measurements
MEASUrement:MEAS<x>:SOURCE<x>:EDGE?	Returns all edge settings for the specified measurement
MEASUrement:MEAS<x>:SOURCE<x>:GATE<x>?	Returns the specified gate<x> settings for measurement <x>
MEASUrement:MEAS<x>:SOURCE<x>:GATE<x>:PCTPos	Sets gate endpoint in percent
MEASUrement:MEAS<x>:SOURCE<x>:GATE<x>:PCTPos?	Return gate endpoint in percent
MEASUrement:MEAS<x>:SOURCE<x>:GATE<x>:POS	Sets gate endpoint in waveform units
MEASUrement:MEAS<x>:SOURCE<x>:GATE<x>:POS?	Returns gate endpoint in waveform units
MEASUrement:MEAS<x>:SOURCE<x>:HILow:METHod	Sets method for calculating high / low levels
MEASUrement:MEAS<x>:SOURCE<x>:HILow:METHod?	Returns the method used to calculate the high / low levels
MEASUrement:MEAS<x>:SOURCE<x>:HILow:TRACK:HIGH:ENABLE	Sets tracking high level on or off
MEASUrement:MEAS<x>:SOURCE<x>:HILow:TRACK:HIGH:ENABLE?	Returns tracking high level on or off
MEASUrement:MEAS<x>:SOURCE<x>:HILow:TRACK:HIGH:VALue	Sets high level
MEASUrement:MEAS<x>:SOURCE<x>:HILow:TRACK:HIGH:VALue?	Returns high level

:HILow:TRACK:HIGh:VALue?	
MEASUrement:MEAS<x>:SOURCE<x>: :HILow:TRACK:LOW:ENABle	Sets tracking low level on or off
MEASUrement:MEAS<x>:SOURCE<x>: :HILow:TRACK:LOW:ENABle?	Returns tracking low level on or off
MEASUrement:MEAS<x>:SOURCE<x>: :HILow:TRACK:LOW:VALue	Sets low level
MEASUrement:MEAS<x>:SOURCE<x>: :HILow:TRACK:LOW:VALue?	Returns low level
MEASUrement:MEAS<x>:SOURCE<x>: :HILow?	Returns all high / low values for measurement<x>
MEASUrement:MEAS<x>:SOURCE<x>: :WFM	Sets the measurement source waveform, and, optionally, the timebase on which measurements are taken
MEASUrement:MEAS<x>:SOURCE<x>: :WFM?	Returns the measurement source
MEASUrement:MEAS<x>:SOURCE<x>: :WFMDB:SIGType	Sets the signal type of the waveform database for the measurement source
MEASUrement:MEAS<x>:SOURCE<x>: :WFMDB:SIGType?	Returns the signal type of the waveform database for measurement source
MEASUrement:MEAS<x>:SOURCE<x>: :WFMDB:STATE	Sets state of Use WfmDb for measurement source to on or off
MEASUrement:MEAS<x>:SOURCE<x>: :WFMDB:STATE?	Returns state of Use WfmDb for measurement source
MEASUrement:MEAS<x>:STATE	Sets the display of measurement <x> on or off
MEASUrement:MEAS<x>:STATE?	Returns the display of measurement <x> on or off
MEASUrement:MEAS<x>:STATistics: :CLEAR	Clears measurement statistics for measurement <x>
MEASUrement:MEAS<x>:STDdev?	Returns measurement statistics standard deviation value for measurement <x>
MEASUrement:MEAS<x>:TYPE	Sets the type of measurement for the specified measurement
MEASUrement:MEAS<x>:TYPE?	Returns the type of measurement for the specified measurement
MEASUrement:MEAS<x>:UNIts?	Returns the units for the specified measurement
MEASUrement:MEAS<x>:VALue?	Returns the measurement value for the specified measurement
MEASUrement:STATistics:ENABle	Sets whether or not measurement statistics are enabled (on or off)
MEASUrement:STATistics:ENABle?	Returns whether or not measurement statistics are enabled (on or off)
MEASUrement:STATistics:WEIGHTing	Sets measurement statistics weighting for all measurements
MEASUrement:STATistics:WEIGHTing?	Returns measurement statistics weighting for all measurements
MEASUrement?	Returns all measurement parameters

Miscellaneous Command Group

Overview

Miscellaneous commands do not fit into other categories. Several commands and queries are common to all 488.2–1987 devices on the GPIB bus. The 488.2–1987 standard defines these commands. The common commands begin with an asterisk (*) character.

Command Descriptions

Command	Description
*IDN?	Returns identification string
*LRN?	Returns "complete" instrument settings
*PSC	Sets the power-on clear flag. When false, registers retain their status when power is restored; when true, registers will be cleared when power is restored
*PSC?	Returns the power-on clear flag. When false, registers retain their status when power is restored; when true, registers will be cleared when power is restored
AUTOSet	Runs autosest
AUTOSet:STOP	Stops autosest
AUTOSet:TYPE	Sets autosest mode (Edge, Period, NRZ Eye, or RZ Eye)
AUTOSet:TYPE?	Returns autosest mode
AUTOSet:UNDO	Undoes autosest
DATE	Sets date (yyyy-mm-dd)
DATE?	Returns date
FACTory	Sets instrument to factory defaults.
FILESystem:READFile?	Outputs the specified file to the GPIB port with maximum file size of 10Mb
HEADer	Response Header Enable command
HEADer?	Response Header Enable query
LOCK	Sets front panel lock state
LOCK?	Returns front panel lock state
SET?	Tek Learn Mode
SYNC:TIMEOUT	Sets or queries the default synchronization timeout for commands that rely upon data production from the instrument
TIME	Sets time of day
TIME?	Returns time of day
UNLock	Unlocks front panel
UNLock?	Query unlock front panel
VERBose	Response header abbreviation control command
VERBose?	Response header abbreviation control query

Save and Recall Command Group

Overview

You use the commands in the Save and Recall Command Group to store and retrieve internal waveforms and settings. When you save a setup, you save all the settings of the instrument. When you recall a saved

setting, the instrument restores itself to the state that it was in when you originally saved that setting.

Command Descriptions

Command	Description
*RST	Returns the instrument settings to the factory defaults. This command does not affect the state of the IEEE interface, the address of the instrument, calibration data that affects device specifications, ESER setting, power on status clear flag, or stored settings.
DELEte:WAVEform	Deletes (one or all) of the stored reference waveforms from memory
EXPort	Exports a waveform, waveform database or histogram data
RECAll:SETup	Recalls saved instrument settings
RECAll:WAVEform	Recalls a stored waveform into reference location
SAVe:SETup	Saves the current instrument settings to a specified location
SAVe:WAVEform	Saves waveform in reference or file

Status and Error Command Group

Overview

You use the commands in the Status and Error command Group to determine the status of the instrument and control events. Several commands and queries used with the instrument are common to all devices on the GPIB bus. The IEEE Std 488.2–1987 defines these commands and queries. The common commands begin with an asterisk (*) character.

Command Descriptions

Command	Description
*CLS	Clear status
*ESE	Sets standard event status enable register
*ESE?	Returns standard event status enable register
*ESR?	Returns standard event status register
*OPC	Sets OPC event when all pending operations are finished.
*OPC?	Returns "1" when all current operations complete
*RST	Resets instrument
*SRE	Sets service request register
*SRE?	Returns service request register
*STB ?	Returns status byte
*WAI	Wait until all current operations complete before processing next command
ALLEv?	Return all events
BUSY?	Return scope status
DESE	Device event status enable
DESE?	Device Event status query
EVENT?	Return event code
EVMsg?	Return event code and message
EVQty?	Return number of events in queue
ID?	Tek identification query

System Command Group

Overview

You use the commands in the System Command Group to obtain information about your system, such as the serial numbers of your instrument, installed modules, and the attached probes, the hardware version of the acquisition and processor circuit boards, and the gains and impedances of attached probes.

Command Descriptions

Command	Description
SYSTem:PROPerTies:ACQHWVer?	Returns hardware version of Acquisition circuit board
SYSTem:PROPerTies:CH<x>:BANdwidth?	Returns a list of available bandwidth selections for the specified channel (optical modules); for electrical modules, returns bandwidth characteristic if applicable
SYSTem:PROPerTies:CH<x>:CAPacitance?	Where applicable, returns sampling module load capacitance of the specified channel
SYSTem:PROPerTies:CH<x>:CLKRec?	Returns list of available clock recovery selections for the specified channel
SYSTem:PROPerTies:CH<x>:DYNamic?	Returns sampling module lower and upper dynamic range limits of the specified channel
SYSTem:PROPerTies:CH<x>:EXTender?	Returns extender cable type of the specified channel
SYSTem:PROPerTies:CH<x>:FILTer?	Returns a list of available filter selections for the specified channel
SYSTem:PROPerTies:CH<x>:IMPedance?	Where applicable, returns sampling module input impedance of the specified channel
SYSTem:PROPerTies:CH<x>:MODElnum?	Returns sampling module model number per specified channel
SYSTem:PROPerTies:CH<x>:NONDestruct?	Where applicable, returns sampling module lower and upper maximum nondestructive range of the specified channel
SYSTem:PROPerTies:CH<x>:OPERating?	Where applicable, returns sampling module lower and upper operating range of specified channel
SYSTem:PROPerTies:CH<x>:PRObe :DYNamic?	Where applicable, returns the probe lower and upper dynamic range limits of the specified channel
SYSTem:PROPerTies:CH<x>:PRObe :IMPedance?	Returns impedance of probe attached to specified channel
SYSTem:PROPerTies:CH<x>:PRObe :MODElnum?	Returns probe model number of the probe attached to the specified channel
SYSTem:PROPerTies:CH<x>:PRObe :SCALE?	Returns the probe scale factor of the probe attached

	to the specified channel
SYSTem:PROPeries:CH<x>:PRObe:SERialnum?	Returns serial number of probe attached to specified channel
SYSTem:PROPeries:CH<x>:RISetime?	Where applicable, returns the sampling module risetime characteristic of the specified channel
SYSTem:PROPeries:CH<x>:SERialnum?	Returns sampling module serial number per specified channel
SYSTem:PROPeries:CH<x>:TEKPDriver?	Returns sampling module TEKPROBE driver revision number of specified channel
SYSTem:PROPeries:CH<x>:TEKPVersion?	Returns sampling module TEKPROBE version number per channel
SYSTem:PROPeries:CH<x>:WLENgth?	Returns list of available wavelength selections for the specified channel
SYSTem:PROPeries:GROup<x>:TEKPVersion?	Return's the version number of the specified TekProbe controller
SYSTem:PROPeries:MAInframe:MODEInum?	Returns mainframe model number
SYSTem:PROPeries:MAInframe:SERialnum?	Returns mainframe serial number
SYSTem:PROPeries:MAInframe:SWVersion?	Returns mainframe software version number
SYSTem:PROPeries:ONTime?	Returns on time for current power up in hours
SYSTem:PROPeries:POWerups?	Returns number of power ups
SYSTem:PROPeries:PROCHWver?	Returns hardware version of Processor circuit board
SYSTem:PROPeries:TOTalontime?	Returns the total accumulated on time in hours (across all power cycles)

TDR Command Group

Overview

You use the commands in the TDR Command Group to do the following:

- Specify TDR step channels (C1 through C8), and select the polarity for each.
- Select TDR steps.
- Enable and disable acquisition.
- Set the TDR internal clock rate.
- Preset any TDR channel.
- Set the channel TDR deskew.
- Select the channel TDR units.
- Obtain all the TDR parameters.

Command Descriptions

Command	Description
TDR:CH<x>:PRESET	Sets the instrument to predefined TDR settings for the specified TDR channel
TDR:CH<x>:STEP:DESkeW	Sets the specified channel TDR deskew (if valid type head in channel)
TDR:CH<x>:STEP:DESkeW?	Returns the TDR deskew for the specified channel
TDR:CH<x>:STEP:POLarity	Sets the TDR step polarity for the specified channel
TDR:CH<x>:STEP:POLarity?	Returns the TDR step polarity for the specified channel
TDR:CH<x>:STEP:STATE	Sets whether the TDR generator is on or off for the specified channel
TDR:CH<x>:STEP:STATE?	Returns whether the TDR generator is on or off for the specified channel
TDR:CH<x>:UNIts	Sets the TDR units for the specified channel
TDR:CH<x>:UNIts?	Returns the TDR units for the specified channel
TDR:INTRate	Sets the TDR (Internal Clock) rate; same as TRIG:INTRATE
TDR:INTRate?	Returns the TDR (Internal Clock) rate; same as TRIG:INTRATE
TDR?	Returns all TDR parameters

Trigger Command Group

Overview

You use the commands in the Trigger Command Group to control all aspects of triggering for the instrument. You use the commands to do the following:

- Set the trigger source for triggering acquisition. You can select an external event (External Direct or External Prescaler), the internal clock, or a clock recovered from the input for the trigger source, depending on your application.
- Set the internal clock rate.
- Set the trigger mode to determine whether, in the loss or absence of triggers, the instrument auto triggers (Auto mode) or stops acquiring (Normal mode).
- Set the signal level and slope (rising or falling) of the trigger. Slope is ignored for internal clock sources.
- Set the trigger level to 50% of the trigger signal amplitude.
- Set trigger holdoff, which is the time the instrument waits before arming the trigger system to accept triggers. Holdoff can help achieve stable triggering.
- Set enhanced triggering (metastability reject, high frequency triggering, and gated triggering) for improved triggering in specific instances.

- Obtain all trigger parameters.
- Obtain the trigger system status (triggered, auto mode, or FrameScan).

Command Descriptions

Command	Description
TRIGger:CH<x>::CLKRec:VALue	Sets the clock recovery value for the specified channel
TRIGger:CH<x>::CLKRec:VALue?	Returns the clock recovery value for the specified channel
TRIGger:CH<x>:CLKRec:LIST?	Returns a list of available clock recovery selections per channel
TRIGger:CLKRec:SOUrce	Selects the clock recovery channel source
TRIGger:CLKRec:SOUrce?	Returns the clock recovery channel source
TRIGger:GATEd	Turns on and off gated triggering. Requires Option GT.
TRIGger:GATEd?	Returns the status for gated triggering (on or off)
TRIGger:HIFreq	Sets high-frequency hysteresis
TRIGger:HIFreq?	Returns high-frequency hysteresis
TRIGger:HOLDoff	Sets trigger holdoff time
TRIGger:HOLDoff?	Returns trigger holdoff time
TRIGger:INTRate	Sets internal clock rate
TRIGger:INTRate?	Returns internal clock rate
TRIGger:LEVel	Sets trigger level
TRIGger:LEVel?	Returns trigger level
TRIGger:METAReject	Enables metastability rejection filter
TRIGger:METAReject?	Returns metastability rejection filter state
TRIGger:MODE	Sets trigger mode
TRIGger:MODE?	Returns trigger mode
TRIGger:SETLevel	Sets trigger level to 50% of applied signal
TRIGger:SLOpe	Sets trigger slope
TRIGger:SLOpe?	Returns trigger slope
TRIGger:SOUrce	Sets trigger source
TRIGger:SOUrce?	Returns trigger source
TRIGger:STATE?	Returns trigger system status
TRIGger?	Returns all trigger parameters

Vertical Command Group

Overview

You use the commands in the Vertical Command Group to control the vertical setup of all live (channel) waveforms for acquisition and to control the display of channel, reference, and math waveforms. This group contains commands to set up the vertical parameters for either electrical or optical signals, depending on the sampling module in use.

You can use the commands in this group to do the following:

- Enable or disable the display of any channel, math, or reference waveform.
- Set which waveform is affected by the front-panel controls.
- Set the vertical scale for each channel.
- Set the vertical position. The vertical position affects only the display position of a channel, math, or reference waveform.
- Set the offset value to shift the vertical acquisition window to match the waveform data that you want to acquire (affects only channels).
- Set deskew values to compensate for delay between channels.
- Set the units for channel waveforms. If you set this value to Auto, the instrument automatically selects the units. If you set this value to any setting other than Auto (Volt, Amp, or Watt), the instrument will apply these units to the vertical axis.
- Set the external attenuation factor (as a multiplier or as a dB value) on an acquisition channel waveform to a value matching the amount of attenuation applied externally, before the signal enters the sampling head or probe tip input.
- Set the wavelength to match the wavelength of the optical signal you are using.
- Set the type of filtering, if any, you want performed on the selected optical channel.
- Specify bandwidth for use on the selected optical channel.

Vertical Command Descriptions

Command	Description
CH<x>:BANdwidth:LIST?	Returns the bandwidths available for the specified channel
CH<x>:BANdwidth:VALue	Sets the bandwidth for the specified channel
CH<x>:BANdwidth:VALue?	Returns the bandwidth selection for the specified channel
CH<x>:DESkew	Sets the deskew time
CH<x>:DESkew?	Returns the deskew time
CH<x>:EXTAtten:MODE	Sets external attenuation mode
CH<x>:EXTAtten:MODE?	Returns external attenuation mode
CH<x>:EXTAtten:VALue	Sets the external attenuation factor (as a multiple)
CH<x>:EXTAtten:VALue?	Returns the external attenuation factor (as a multiplier)
CH<x>:FILTer:LIST?	Returns filter list for the specified channel
CH<x>:FILTer:VALue	Sets the hardware filter for the specified channel
CH<x>:FILTer:VALue?	Returns the hardware filter, if any, selected for the specified channel
CH<x>:OFFSet	Sets channel offset
CH<x>:OFFSet?	Returns channel offset setting

CH<x>:POsition	Sets channel vertical position
CH<x>:POsition?	Returns channel vertical position
CH<x>:SCAle	Sets channel vertical scale (per div)
CH<x>:SCAle?	Returns channel vertical scale (per div)
CH<x>:UNIts	Sets channel vertical units
CH<x>:UNIts?	Returns channel vertical units
CH<x>:WFMLabel	Sets or queries the label associated with the specified channel waveform
CH<x>:WLENgth:LIST?	Returns the wavelengths available for the specified channel
CH<x>:WLENgth:VALue	Sets the wavelength for the specified channel
CH<x>:WLENgth:VALue?	Returns wavelength setting for the specified channel
CH<x>?	Returns vertical parameters
MATH<x>:POsition	Sets math vertical position
MATH<x>:POsition?	Returns math vertical position
MATH<x>:SCAle	Sets math vertical scale (per div)
MATH<x>:SCAle?	Returns math vertical scale (per div)
REF <x>:POsition?	Returns reference vertical position
REF<x>:POsition	Sets reference vertical position
REF<x>:SCAle	Sets reference vertical scale (per div)
REF<x>:SCAle?	Returns reference vertical scale (per div)
REF<x>:WFMLabel	Sets or queries the label associated with the specified reference waveform
SElect:CH<x>	Turn a waveform ON/OFF (main timebase)
SElect:CH<x>?	Returns waveform ON/OFF state (main timebase)
SElect:CONTROL	Sets waveform controlled by front panel. Note: NONE may be returned by *LRN?. If this is an argument, do nothing. Also, timebase is NOT optional
SElect:CONTROL?	Returns the waveform and timebase selected for front-panel control.
SElect:MATH<x>	Turn a waveform ON/OFF (main timebase)
SElect:MATH<x>?	Returns waveform ON/OFF state (main timebase)
SElect:REF<x>	Turn a waveform ON/OFF (main timebase)
SElect:REF<x>?	Returns waveform ON/OFF state (main timebase)
SElect?	Returns information on which waveforms are ON/OFF and which waveform is the selected waveform.

Waveform Database Command Group

Overview

You use the commands in the Waveform Database Command group to view and set up a waveform database. A waveform database is a collection of sequentially acquired waveforms. Think of a waveform database as a three-dimensional array with a count dimension in addition to the usual vertical and horizontal dimensions. The count represents the

number of times a specific waveform point has been acquired or generated. Waveform database accumulation is always a dot mode accumulation (that is, no interpolation or vectoring is performed).

Waveform database count values stored in the waveform database array are unit-less with respect to absolute user units (for example, volts or seconds). They are described by the attributes of the source waveform along with the overall dimensions of the array.

The following are the dimensions of a waveform database:

- Horizontal (columns). Value is 500, which is the maximum horizontal graticule view size.
- Vertical (rows). Value is 402, which is the maximum vertical graticule view size in pixels, plus one row each for the overrange (OR) and the underrange (UR) counts for each column.
- Count (weights or density). Value is 32 bits.

Use waveform databases for measurements, histogram calculations and display, mask testing, and generating a density-style graded display. If the source is a displayed waveform database, then the mask testing, histogram calculations, and measurements will use the waveform database.

You can use the commands in this group to do the following:

- Set the source to which the waveform database is assigned.
- Enable or disable the waveform database.
- Set whether the waveform database is displayed.
- Set the signal type of the waveform database (pulse or eye).
- Set whether you want the waveform database drawn with color or intensity grading.
- Set the display emphasis for the waveform database. The value you specify sets the range of counts you want emphasized. The lowest value, 0, emphasizes bins with low counts; the highest value, 100, emphasizes bins with high counts.
- Invert the mapping function that applies colors and intensity to the waveform database to significantly emphasize the least occurring pixels.
- Clear the specified waveform database.
- Obtain all the waveform database display parameters.
- Obtain all the waveform database parameters.

Waveform Database Command Descriptions

Command	Description
WFMDB:DISPlay:EMPHasis	Sets WfmDB display emphasis
WFMDB:DISPlay:EMPHasis?	Returns WfmDB display emphasis
WFMDB:DISPlay:GRADing	Sets WfmDB grading type

WFMDB:DISPlay:GRADing?	Returns WfmDB grading type
WFMDB:DISPlay:INVert	Sets WfmDB grading inversion
WFMDB:DISPlay:INVert?	Returns WfmDB grading inversion
WFMDB:DISPlay?	Returns wWmDB display parameters
WFMDB:WFMDB<x>:CLEAR	Deletes (clears) resource of specified WfmDB
WFMDB:WFMDB<x>:DISPlay	Sets WfmDB<x> displayed
WFMDB:WFMDB<x>:DISPlay?	Returns WfmDB<x> displayed
WFMDB:WFMDB<x>:ENABLE	Enables or disables the specified waveform database
WFMDB:WFMDB<x>:ENABLE?	Returns whether the specified waveform database is enabled
WFMDB:WFMDB<x>:SOURce	Sets WfmDB<x> source
WFMDB:WFMDB<x>:SOURce?	Returns WfmDB<x> source
WFMDB:WFMDB<x>?	Returns WfmDB<x> parameters
WFMDB?	Returns all WfmDB parameters

Waveform Transfer Command Group

Overview

You use the commands in the Waveform Transfer Command Group to transfer waveform data points to and from the instrument. Waveform data points are a collection of values that define a waveform. One data value usually represents one data point in the waveform record. When working with envelope waveforms, each data value is either the minimum or the maximum of a min/max pair. Before you transfer waveform data, you must specify the data format, record length, and waveform source.

Data Formats

Acquired waveform data uses 14 or more bits to represent each data point. The number of bits used depends on the acquisition mode specified when you acquired the data. Data acquired in SAMple or ENVElope mode uses 14 bits per waveform data point. Data acquired in AVERage mode uses up to 16 bits per point.

The instrument can transfer waveform data in either ASCII or binary format. You specify the format with the DATA:ENCdg command. The instrument uses signed, 4 byte integers and floating point values; it does not support unsigned values.

ASCII data is represented by signed integer or floating point values. An example of an ASCII waveform data string may look like this:

```
:CURVE -509476864,-512163840,-511115264,-510918656,
-516161536,-484179968,-117112832,207093760,
322437120,351600640,409206784,468451328,
482934784,490668032,495517696,432668672,
482148352,483655680,493617152,495321088,
499843072,493420544,488964096,497221632, ...
```

ASCII will produce more readable and more easily formatted output than that produced by binary format. However, ASCII may require more bytes

to send the same values than it does with binary. This may reduce transmission speeds.

Binary data can be represented by signed integer or floating-point values. The defined binary formats specify the order in which the bytes are transferred. The following are the four binary formats:

- RIBinary specifies signed integer data-point representation with the most significant byte transferred first.
- SRIBinary is the same as RIBinary except that the byte order is reversed; the least significant byte is transferred first. This format is useful when transferring data to IBM-compatible PCs
- FPBinary specifies floating-point data-point representation with the most significant byte transferred first.
- SFPBinary is the same as RFBinary except that the byte order is reversed; the least significant byte is transferred first. This format is useful when transferring data to IBM-compatible PCs.

Waveform Data and Record Lengths

You can transfer multiple points for each waveform record. You can transfer a portion of the waveform or you can transfer the entire record. You can use the DATA:START and DATA:STOP commands to specify the first and last data points of the waveform record. The instrument supports record lengths of 20, 50, 100, 250, 500, 1000, 2000, and 4000 samples.

When transferring data into the instrument, you must first specify the record length of the destination waveform record. To specify the record length, use the WFMInpre:NR_Pt command. Next, specify the first data point within the waveform record. For example, when you set DATA:START to 1, data points will be stored starting with the first point in the record. The instrument will ignore the value set by DATA:STOP when reading in data. It will stop reading in data when there is no more data to read, or when it has reached the specified record length.

When transferring data from the instrument, you must specify the first and last data points in the waveform record. Setting DATA:START to 1 and DATA:STOP to the record length will always return the entire waveform.

Waveform Data Locations and Memory Allocation

The DATA:SOURce and DATA:TIMEbase commands specify the waveform source and waveform timebase when transferring a waveform from the instrument. You can only transfer one waveform at a time.

Waveforms sent to the instrument are always stored in one of the eight reference memory locations. You use the DATA:DESTination command to specify a reference memory location.

Waveform Preamble

Each waveform that you transfer has an associated waveform preamble that contains information such as the horizontal scale, the vertical scale, and other settings in effect when the waveform was created. The values returned by the WFMOutpre query commands are set by the previous

curve query. Therefore, to have a valid set of preamble and data, you must perform a CURVe? query followed by a WFMOutpre? query. Refer to the individual WFMInpre and WFMOutpre commands for more information.

Waveform Transfer Command Descriptions

Command	Description
CURVe	Transfer waveform data to the instrument (reference memory location specified by DATA:DESTination)
CURVe?	Transfers waveform data from instrument specified by the DATA:SOURce command
DATA	Sets the waveform data format and location
DATA?	Returns waveform data format and location
DATA:DESTination	Sets Destination for waveforms sent to scope
DATA:DESTination?	Returns Destination for waveforms sent to scope
DATA:ENCdg	Sets Waveform data encoding method
DATA:ENCdg?	Returns Waveform data encoding method
DATA:SOURce	Query location of waveform data transferred from the instrument by the CURVe?
DATA:SOURce?	Query location of waveform data transferred from the instrument by the CURVe?
DATA:STARt	Set starting point in waveform transfer
DATA:STARt?	Returns starting point in waveform transfer
DATA:STOP	Sets ending point in waveform transfer
DATA:STOP?	Returns ending point in waveform transfer
DATA:TIMEbase	Sets the timebase location of SOURce waveform data transferred from the instrument by the CURVe? command.
WAVFrm?	Returns data followed by corresponding outgoing preamble.
WFMInpre:BIT_Nr?	Returns Bit width of waveform points
WFMInpre:BN_Fmt	Sets Binary encoding format
WFMInpre:BN_Fmt?	Returns Binary encoding format
WFMInpre:BYT_Nr?	Returns Byte width of waveform points
WFMInpre:BYT_Or	Sets Byte order of waveform points
WFMInpre:BYT_Or?	Returns Byte order of waveform points
WFMInpre:ENCdg	Set Data encoding method
WFMInpre:ENCdg?	Returns Data encoding method
WFMInpre:NR_Pt	Sets Number of points in the curve
WFMInpre:NR_Pt?	Returns Number of points in the curve
WFMInpre:PT_Fmt	Sets Format of incoming waveform data
WFMInpre:PT_Fmt?	Returns Format of incoming waveform data
WFMInpre:WFMLabel	Sets waveform label
WFMInpre:WFMLabel?	Returns waveform label
WFMInpre:XINcr	Sets Horizontal sampling interval (time between samples)
WFMInpre:XINcr?	Returns Horizontal sampling interval (time between samples)
WFMInpre:XMULT	Sets horizontal scale in horizontal units per division
WFMInpre:XMULT?	Returns horizontal scale in horizontal units per division
WFMInpre:XOFF	Sets horizontal position in horizontal units

WFMInpre:XOFF?	Returns horizontal position in horizontal units
WFMInpre:XUNit	Sets Horizontal units
WFMInpre:XUNit?	Returns Horizontal units
WFMInpre:XZero	Sets Horizontal origin offset
WFMInpre:XZero?	Returns Horizontal origin offset (time of first point)
WFMInpre:YMUlt	Sets vertical scale factor
WFMInpre:YMUlt?	Returns Vertical scale factor (external attenuation included?)
WFMInpre:YOFF	Sets vertical offset
WFMInpre:YOFF?	Returns vertical offset (vertical position in divisions)
WFMInpre:YSCALE	Sets the vertical unit scale factor
WFMInpre:YSCALE?	Returns the vertical unit scale factor
WFMInpre:YUNit	Sets vertical units
WFMInpre:YUNit?	Returns vertical units
WFMInpre:YZero	Sets offset voltage
WFMInpre:YZero?	Returns offset voltage (Vertical offset in volts)
WFMInpre?	Returns preamble for incoming waveforms
WFMOutpre:BIT_Nr?	Returns Bit width of waveform points
WFMOutpre:BN_Fmt	Sets Binary encoding type
WFMOutpre:BN_Fmt?	Returns Binary encoding type
WFMOutpre:BYT_Nr?	Returns Byte width of waveform points
WFMOutpre:BYT_Or	Sets Byte order of waveform points
WFMOutpre:BYT_Or?	Returns Byte order of waveform points
WFMOutpre:ENCdg	Sets data encoding method
WFMOutpre:ENCdg?	Returns Data encoding method
WFMOutpre:NR_Pt?	Returns number of points in the curve
WFMOutpre:PT_Fmt?	Returns format of curve points
WFMOutpre:WFId?	Returns curve identifier
WFMOutpre:WFMLabel?	Returns the outgoing waveform label
WFMOutpre:XINcr?	Returns horizontal sampling interval
WFMOutpre:XOFF?	Returns the horizontal position in horizontal units
WFMOutpre:XUNit?	Returns the horizontal units
WFMOutpre:XZero?	Returns horizontal origin offset
WFMOutpre:YMUlt?	Returns the vertical scale factor
WFMOutpre:YOFF?	Returns the vertical offset
WFMOutpre:YSCALE?	Returns the vertical unit scale factor
WFMOutpre:YUNit?	Returns the vertical units
WFMOutpre:YZero?	Returns offset voltage
WFMOutpre?	Returns preamble for outgoing waveforms

Commands

This section lists commands and queries alphabetically and describes them and their arguments.

*CLS

This command (no query form) clears the following status data structures of the instrument:

- Event Queue
- Standard Event Status Register (SESR)
- Status Byte Register (except the MAV bit; see below)

If the *CLS command immediately follows an <EOI>, the Output Queue and MAV bit (Status Byte Register bit 4) are also cleared. MAV indicates information is in the output queue. The device clear (DCL) GPIB control message will clear the output queue and thus MAV. *CLS does not clear the output queue or MAV. (For more information about these registers and bits, and of event handling in general, see the *Status and Events Overview*, on page 337, and its subtopics.)

*CLS can suppress a service request that is to be generated by an *OPC. This will happen if a hardcopy output or single sequence acquisition operation is still being processed when the *CLS command is executed.

Group

Status and Error

Related Commands

DESE, *ESE, *ESR?, EVENT?, EVMsg?, *SRE, *STB?

Syntax

*CLS

*ESE

This command sets or queries the bits in the Event Status Enable Register (ESER). The ESER prevents events from being reported to the Status Byte Register (SBR). For a more detailed discussion of the use of these registers, see *Registers* on page 337.

Group

Status and Error

Related Commands

*CLS, DESE, *ESR?, EVENT?, EVMsg?, *SRE, *STB?

Syntax 1

*ESE <NR1>

Syntax 2

*ESE?

Argument

NR1

This is a value in the range from 0 through 255. The binary bits of the ESER are set according to this value.

The power-on default for ESER is 0 if *PSC is 1. If *PSC is 0, the ESER maintains its value through a power cycle.

Note: Setting the DESER and the ESER to the same value allows only those codes to be entered into the Event Queue and summarized on the ESB bit (bit 5) of the Status Byte Register. Use the DESE command to set the DESER. See Event Handling Sequence on page 341 for a discussion of event handling.

Example 1

*ESE 209

Sets the ESER to binary 11010001, which enables the PON, URQ, EXE, and OPC bits.

Example 2

*ESE?

This query might return the string *ESE 186, indicating that the ESER contains the binary value 10111010.

*ESR?

This is a query only command that returns the contents of the Standard Event Status Register (SESR). This query also clears the SESR, since reading the SESR clears it. For a more detailed discussion of the use of these registers, see *Registers* on page 337.

Group

Status and Error

Related Commands

ALLEv?, *CLS, DESE, *ESE, EVENT?, EVMsg?, *SRE, *STB?

Syntax

*ESR?

Example

*ESR?

This query might return the value 213, showing that the SESR contains binary 11010101.

*IDN?

This is a query only command that returns the instrument identification code.

Group

Miscellaneous

Related Commands

ID?

Syntax

*IDN?

Returns

The instrument ID in the following format:

```
TEKTRONIX,<model number>,0,CF:92.1CT FV  
:<firmware version number>
```

Example

*IDN?

This query might return the response

```
TEKTRONIX,TDS8000,0,CF:91.1CT FV:1.0.444.
```

*LRN?

This query only command returns a string listing the instrument settings, except for configuration information for the calibration values. You can use this string to return the instrument to the state it was in when you made the *LRN? query. This command is identical to the SET? query.

Group

Miscellaneous

Related Commands

HEADer, SET?, VERBose

Syntax

*LRN?

*Note: The *LRN? query always returns a string including command headers, regardless of the setting of the HEADer command. This is because the returned string is intended to be sent back to the instrument as a command string. The VERBose command can still be used normally to specify whether the returned headers should be abbreviated.*

Example

*LRN?

A partial response to this query might be the following:

```
:ACQUIRE:STATE 1;MODE SAMPLE;NUMENV 10;NUMAVG 16;  
REPET 1;STOPAFTER RUNSTOP;;DIAG:LOOP:OPTION ONCE;  
COUNT 1;;DIAG:STATE HALT;;HEADER 1;;VERBOSE 1;  
:CURSOR:FUNCTION OFF;VBARS:UNITS SECONDS;  
POSITION1 1.00E-6;POSITION2 9.00E-6;SELECT CURSOR1;
```

*OPC

This command generates the operation complete message in the Standard Event Status Register (SESR) when all pending operations finish. The *OPC? query places the ASCII character "1" into the output queue when all pending operations are finished. The *OPC? response is not available to read until all pending operations finish. For a complete discussion of

the use of these registers and the output queue, see *Registers*, on page 337, and *Queue* on page 340.

The *OPC command allows you to synchronize the operation of the instrument with your application program. For more information, see *Synchronization Methods* on page 342.

Commands that Generate an OPC Message	
Operation	Command
Automatic instrument adjustment	AUTOSet EXECute
Internal self compensation	COMPensate:ALL COMPensate:CH<x> COMPensate:DARKLev:CH<x> COMPensate:MAInframe COMPensate:OPTGAIN:CH<x>
Conditional	ACQuire:STATE ON or ACQuire:STATE RUN (when ACQuire:STOPAfter is set to CONDition)
Hardcopy output	HARDCopy START

Group

Status and Error

Related Commands

BUSY?, *WAI

Syntax 1

*OPC

Syntax 2

*OPC?

This query returns 1 when all pending operations are finished.

*PSC

This command sets or queries the power-on status flag that controls the automatic power-on handling of the DESER, SRER, and ESER registers. When *PSC is true, the DESER register is set to 255 and the SRER and ESER registers are set to 0 at power on. When *PSC is false, the current values in the DESER, SRER, and ESER registers are retained in nonvolatile memory when the instrument is powered off and are restored when the instrument is powered on.

Group

Miscellaneous

Syntax 1

*PSC <NR1>

Syntax 2

*PSC?

Argument

NR1

When this argument is 0, the power-on status clear flag is set to false. When the argument is not equal to 0, the power-on status clear flag is set to true.

Example 1

*PSC 0

This command sets the power-on status flag to false, causing the values in the DESER, SRER, and ESER registers to be retained in nonvolatile memory when the instrument is powered off and restored when it is powered on.

Example 2

*PSC?

This query might return the value 1, indicating that the power-on status clear flag is set to true.

*RST

This command resets the instrument to the factory default settings. There is no query form of this command.

The *RST command does not alter the following:

- The state of the IEEE Std 488.1-1987 interface
- The selected IEEE Std 488.1-1987 address of the instrument
- Calibration data that affect device specifications
- The Output Queue
- The Service Request Enable Register setting
- The Standard Event Status Enable Register setting
- The Power-on status clear flag setting
- Alias definitions
- Stored settings
- The *PUD? response

Group

Status and Error, Save and Recall

Related Commands

FACtory, RECALL:SETUp, SAVe:SETUp

Syntax

*RST

This command returns the instrument settings to the factory defaults.

*SRE

The *SRE (Service Request Enable) command sets and queries the bits in the Service Request Enable Register (SRER). For more information, refer to *Registers*.

Group

Status and Error

Related Commands

*CLS, DESE, *ESE, *ESR?, EVENT?, EVMSg?, FACtory, *STB?

Syntax 1

*SRE <NR1>

Syntax 2

*SRE?

Argument

NR1

This is a value in the range from 0 to 255. The binary bits of the SRER are set according to this value. Using an out-of-range value causes an execution error. The power-on default for SRER is 0 if *PSC is 1. If *PSC is 0, the SRER maintains its value throughout a power cycle.

Example 1

*SRE 48

Sets the bits in the SRER to 00110000 binary.

Example 2

*SRE?

This query might return a value of 32, showing that the bits in the SRER have the binary value 00100000.

*STB?

The *STB? (Read Status Byte) query returns the contents of the Status Byte Register (SBR) using the Master Summary Status (MSS) bit. For more information, refer to *Registers*.

Group

Status and Error

Related Commands

*CLS, DESE, *ESE, *ESR?, EVENT?, EVMSg?, FACtory, *SRE

Syntax

*STB?

Return Value

<NR1>

Example

*STB?

This query might return the value 96, showing that the SBR contains the binary value 01100000.

***WAI**

The *WAI (Wait) command (no query form) prevents the instrument from executing further commands or queries until all pending operations finish. This command allows you to synchronize the operation of the instrument with your application program. For more information, refer to *Synchronization Methods*.

Group

Status and Error

Related Commands

BUSY?, *OPC

Syntax

*WAI

ACQUIRE:CURRENTCOUNT:ACQWFMS?

This query only command returns the current count value of acquired waveforms. The target value of this count is set by the ACQUIRE:STOPAFTER:COUNT command (in conjunction with the ACQUIRE:STOPAFTER:CONDITION command). The instrument then counts up to this value. When the count reaches (or exceeds) the value, acquisition stops, and the specified StopAfter action is enabled.

Group

Acquisition

Related Commands

ACQUIRE:STOPAFTER:COUNT, ACQUIRE:STOPAFTER:CONDITION

Syntax

ACQUIRE:CURRENTCOUNT:ACQWFMS?

Returns

NR1

This is the current count value of acquired waveforms.

Example

ACQUIRE:CURRENTCOUNT:ACQWFMS?

This query might return :ACQUIRE:CURRENTCOUNT:ACQWFMS 20, indicating that currently 20 waveforms have been acquired.

ACQUIRE:CURRENTCOUNT:HISTHITS?

This query only command returns the current count value of histogram hits. The target value of this count is set by the ACQUIRE:STOPAFTER:COUNT command (in conjunction with the ACQUIRE:STOPAFTER:CONDITION command). The instrument then counts

up to this value. When the count reaches (or exceeds) this value, acquisition stops, and the specified StopAfter action is enabled.

Group

Acquisition

Related Commands

ACQUIRE:STOPAfter:COUNT, ACQUIRE:STOPAfter:CONDITION

Syntax

ACQUIRE:CURRENTcount:HISTHits?

Returns

NR1

This is the current count value of histogram hits.

Example

ACQUIRE:CURRENTcount:HISTHits?

This query might return :ACQUIRE:CURRENTCOUNT:HISTHITS
100, indicating that currently 100 histogram hits have been acquired.

ACQUIRE:CURRENTcount:HISTWfms?

This query only command returns the current count value of waveforms accumulated for histograms. The target value of this count is set by the ACQUIRE:STOPAfter:COUNT command (in conjunction with the ACQUIRE:STOPAfter:CONDITION command). The instrument then counts up to this value. When the count reaches (or exceeds) this value, acquisition stops, and the specified StopAfter action is performed.

Group

Acquisition

Related Commands

ACQUIRE:STOPAfter:COUNT, ACQUIRE:STOPAfter:CONDITION

Syntax

ACQUIRE:CURRENTcount:HISTWfms?

Returns

NR1

This is the current count value of histogram waveforms.

Example

ACQUIRE:CURRENTcount:HISTWfms?

This query might return :ACQUIRE:CURRENTCOUNT:HISTWFMS
25, indicating that currently 25 waveforms have been acquired in the histogram.

ACQUIRE:CURRENTcount:MASKHits<n>?

This query only command returns the current count value of hits in the specified mask polygon, which can be 1 through 8. The target value of

this count is set by the ACQUIRE:STOPAfter:COUNT command (in conjunction with the ACQUIRE:STOPAfter:CONDITION command). The instrument then counts up to this value. When the count reaches (or exceeds) this value, acquisition stops, and the specified StopAfter action is enabled.

Group

Acquisition

Related Commands

ACQUIRE:STOPAfter:COUNT, ACQUIRE:STOPAfter:CONDITION

Syntax

```
ACQUIRE:CURRENTcount:MASKHits<n>?
```

Returns

NR1

This is the current count value of hits for the specified mask polygon, which can be 1 through 8.

Example

```
ACQUIRE:CURRENTcount:MASKHits4?
```

This query might return :ACQUIRE:CURRENTCOUNT:MASKHITS4 300, indicating that currently 300 mask hits have been acquired in mask 4.

ACQUIRE:CURRENTcount:MASKSamples?

This query only command returns the current count value of mask samples. The target value of this count is set by the ACQUIRE:STOPAfter:COUNT command (in conjunction with the ACQUIRE:STOPAfter:CONDITION command). The instrument then counts up to this value. When the count reaches (or exceeds) this value, acquisition stops, and the specified StopAfter action is performed.

Group

Acquisition

Related Commands

ACQUIRE:STOPAfter:COUNT, ACQUIRE:STOPAfter:CONDITION

Syntax

```
ACQUIRE:CURRENTcount:MASKSamples?
```

Returns

NR1

This is the current count value of mask samples accumulated for mask testing.

Example

```
ACQUIRE:CURRENTcount:MASKSamples?
```

This query might return
:ACQUIRE:CURRENTCOUNT:MASKSAMPLES 75, indicating that
currently 75 mask samples have been acquired for mask testing.

ACQUIRE:CURRENTCOUNT:MASKTHITS?

This query only command returns the current total count value of mask hits. The target value of this count is set by the ACQUIRE:STOPAFTER:COUNT command (in conjunction with the ACQUIRE:STOPAFTER:CONDITION command). The instrument then counts up to this value. When the count reaches (or exceeds) this value, acquisition stops, and the specified StopAfter action is performed.

Group

Acquisition

Related Commands

ACQUIRE:STOPAFTER:COUNT, ACQUIRE:STOPAFTER:CONDITION

Syntax

ACQUIRE:CURRENTCOUNT:MASKTHITS?

Returns

NR1

This is the current count value of mask hits.

Example

ACQUIRE:CURRENTCOUNT:MASKTHITS?

This query might return :ACQUIRE:CURRENTCOUNT:MASKTHITS
300, indicating that currently 300 mask hits have been acquired.

ACQUIRE:CURRENTCOUNT:MASKWFMS?

This query only command returns the current count value of mask waveforms. The target value of this count is set by the ACQUIRE:STOPAFTER:COUNT command (in conjunction with the ACQUIRE:STOPAFTER:CONDITION command). The instrument then counts up to this value. When the count reaches (or exceeds) this value, acquisition stops, and the specified StopAfter action is performed.

Group

Acquisition

Related Commands

ACQUIRE:STOPAFTER:COUNT, ACQUIRE:STOPAFTER:CONDITION

Syntax

ACQUIRE:CURRENTCOUNT:MASKWFMS?

Returns

NR1

This is the current count value of waveforms accumulated for mask testing.

Example

ACQUIRE:CURRENTCOUNT:MASKWFMS?

This query might return :ACQUIRE:CURRENTCOUNT:MASKWFMS 25, indicating that currently 25 waveforms have been acquired for mask testing.

ACQUIRE:DATA:CLEAR

This command (no query form) causes an acquisition reset and clears all acquired data, clears the display, and, if active, resets FrameScan. When a clear data occurs, it has the following effects:

- Sample-mode waveform. The current waveform data is replaced by the waveform data of the next acquisition cycle when it is available.
- Average-mode waveform. The average algorithm mode resets such that the next acquisition will be a straight-through copy.
- Envelope-mode waveform. The envelope algorithm mode resets such that the next acquisition will be a straight-through copy.
- Waveform database. The contents of the database will be cleared (reset to zero) at the start of the next acquisition cycle before adding the next acquisition.
- Histogram data and statistics. The data and all statistics will be cleared immediately.
- Mask counts and statistics. Mask counts and all statistics will be cleared immediately.
- Acquisition status. The acquisition waveform count or StopAfter condition is reset and target counts are reloaded.
- Counts. Resets all counts, including number of acquired waveforms, acquisition and math average counts, conditional stop counts, and FrameScan counts (if any of these are active).
- Measurement statistics. Measurement statistics are reset.

Group

Acquisition

Syntax

ACQUIRE:DATA:CLEAR

Example

ACQUIRE:DATA:CLEAR

This command causes an acquisition reset and clears all acquired data.

ACQUIRE:MODE

This command sets or queries the acquisition mode of the instrument, which determines how the final value of the acquisition interval is generated from the many data samples. The instrument applies the

specified mode globally to all channel waveforms that it acquires. Sending this command is equivalent to selecting the Acquisition Mode in the Acquisition Setup dialog box.

Normally, the instrument takes one sample per trigger and builds a channel waveform over many successive triggers. If acquiring continues, the instrument writes over the acquired waveform with each newly acquired waveform from the same channel. You can modify this behavior by setting the instrument to use one of the three, mutually exclusive acquisition modes:

- **Sample.** Use Sample mode to see the signal in its purest form with no post processing. This is the default mode.
- **Average.** Use Average mode to reduce the apparent noise in the signal to reveal fundamental waveform behavior.
- **Envelope.** Use Envelope mode when it's important to see the variation of extremes in a waveform over time.

Group

Acquisition

Related Commands

ACQUIRE:NUMAVG

Syntax 1

ACQUIRE:MODE {SAMPLE|AVERAGE|ENVELOPE}

Syntax 2

ACQUIRE:MODE?

Arguments

- **SAMPLE**
Specifies sample mode, in which the displayed data point value is simply the first sampled value that was taken during the acquisition interval. There is no post processing of acquired samples; the instrument overwrites waveforms at each new acquisition cycle. **SAMPLE** is the default acquisition mode.
- **AVERAGE**
Specifies averaging mode, in which the resulting waveform shows an average of **SAMPLE** data points from several consecutive waveform acquisitions. The instrument processes the number of waveforms you specify into the acquired waveform, creating a running back-weighted exponential average of the input signal. The number of waveform acquisitions that go into making up the average waveform is set or queried using the **ACQUIRE:NUMAVG** command.
- **ENVELOPE**
Specifies envelope mode, in which the instrument continuously, as subsequent waveforms are acquired, retains the running minimum (Min) and maximum (Max) values in adjacent sample intervals, creating an envelope of all waveforms acquired for that channel.

Example 1

```
ACQuire:MODE ENVELOpe
```

Sets the acquisition mode to display a waveform that is an envelope of many individual waveform acquisitions.

Example 2

```
ACQuire:MODE?
```

This command might return `:ACQUIRE:MODE AVERAGE`, indicating that the displayed waveform is the average of the specified number of waveform acquisitions.

ACQuire:NUMAVg

This command sets or queries the number of waveform acquisitions that make up an averaged waveform. Sending this command is equivalent to setting the number of samples in the Acquisition Mode section of the Acquisition Setup dialog box when Average is checked for the Acquisition Mode. Use the `ACQuire:MODE` command to enable the Average mode.

Group

Acquisition

Related Commands

`ACQuire:MODE`

Syntax 1

```
ACQuire:NUMAVg <NR1>
```

Syntax 2

```
ACQuire:NUMAVg?
```

Arguments

NR1

This is the number of consecutive waveform acquisitions (from 2 to 4,096) used for averaging.

Example 1

```
ACQuire:NUMAVg 10
```

This command specifies that an averaged waveform will show the result of combining 10 separately acquired waveforms.

Example 2

```
ACQuire:NUMAVg?
```

This command might return `:ACQUIRE:NUMAVG 75`, indicating that there are 75 acquisitions specified for averaging.

ACQuire:SAVEFile:SAVEScreen

This command sets or queries the file to which a screen is saved at the completion of a StopAfter condition (when the StopAfter action is set to SAVEScreen). See the `ACQuire:STOPAfter:ACTion` command. The screen is saved in the specified file in .BMP format. This is equivalent to

selecting Print Screen to File in the Stop Action section of the Acquisition Setup dialog box and entering a file name.

Group

Acquisition

Related Commands

ACQUIRE:STOPAfter:ACTION, ACQUIRE:STOPAfter:CONDITION, ACQUIRE:STOPAfter:MODE

Syntax 1

```
ACQUIRE:SAVEFile:SAVEScreen <Qstring>
```

Syntax 2

```
ACQUIRE:SAVEFile:SAVEScreen?
```

Argument

<Qstring>

This quoted string defines the file name and path. Input the file path using the form <drive>/<dir>/<filename>. The <drive> and one or more <dir> arguments are optional. If you do not specify them, the instrument will copy the file into the current directory. The <filename> can be a Windows 95/Windows 98 long file name. Do not use wild card characters.

Example 1

```
ACQUIRE:SAVEFile:SAVEScreen "Wavetest.bmp"
```

This command specifies the file Wavetest.bmp (in the current directory) to which the screen will be saved after a StopAfter SAVEScreen condition is met.

Example 2

```
ACQUIRE:SAVEFile:SAVEScreen?
```

This query might return :ACQUIRE:SAVEFILE:SAVESCREEN "TESTFILE.BMP", indicating that the screen will be saved in TESTFILE.BMP in the current directory when the StopAfter action is enabled.

ACQUIRE:SAVEFile:SAVEWfm

This command sets or queries the file to which waveform data is saved at the completion of a StopAfter condition (when the StopAfter action is set to SAVEWaveform). See the ACQUIRE:STOPAfter:ACTION command. This is equivalent to selecting Save All Waveforms in the Stop Action section of the Acquisition Setup dialog box and entering a file name. This command sets the base file name and path used when multiple waveforms are saved. Each saved waveform has the base file name with a unique index number appended to it to prevent overwriting of the files.

Group

Acquisition

Related Commands

ACQUIRE:STOPAfter:ACTion, ACQUIRE:STOPAfter:CONDition,
ACQUIRE:STOPAfter:MODE

Syntax 1

```
ACQUIRE:SAVEFile:SAVEWfm <Qstring>
```

Syntax 2

```
ACQUIRE:SAVEFile:SAVEWfm?
```

Argument

<Qstring>

This quoted string defines the base file name and path. Input the file path using the form <drive>/<dir>/<filename>. The <drive> and one or more <dir> arguments are optional. If you do not specify them, the instrument will copy the file into the current directory. The <filename> can be a Windows 95/Windows 98 long file name. Do not use wild card characters. An index number is attached to the base filename each time this command is sent so that the file is not overwritten. For example, a file with the base name Wave.doc will be saved as Wave1.doc the first time, Wave2.doc the second time, and so on.

Example 1

```
ACQUIRE:SAVEFile:SAVEWfm "Wave.doc"
```

This command specifies the file Wave1.doc (in the current directory) to which the screen will be saved after a StopAfter SAVEWfm condition is met.

Example 2

```
ACQUIRE:SAVEFile:SAVEWfm?
```

This query might return :ACQUIRE:SAVEFILE:SAVEWFM
"WAVETST.DOC", indicating that the waveform data will be saved in WAVETST.DOC in the current directory when the StopAfter action is enabled.

ACQUIRE:STATE

This command starts or stops acquisitions or queries whether the acquisition is running or stopped. Sending this command is equivalent to pressing the front-panel RUN/STOP button. The ACQUIRE:STOPAfter:MODE and ACQUIRE:STOPAfter:CONDition commands may cause other signal events to also stop acquisition.

Group

Acquisition

Related Commands

ACQUIRE:STOPAfter:MODE, ACQUIRE:STOPAfter:CONDition

Syntax 1

```
ACQUIRE:STATE {OFF|ON|RUN|STOP|<NR1>}
```

Syntax 2

ACQUIRE:STATE?

Arguments

- OFF
Stops acquisitions.
- STOP
Stops acquisitions.
- ON
Starts acquisitions.
- RUN
Starts acquisitions.
- NR1
0 stops acquisitions; any other value starts acquisitions.

Example 1

ACQUIRE:STATE RUN

Starts acquisition of waveform data.

Example 2

ACQUIRE:STATE?

This query might return :ACQUIRE:STATE 1, indicating that the acquisition system is running.

NOTE: A query always returns a 0 or 1.

ACQUIRE:STOPAFTER:ACTION

This command sets or queries the action that the instrument performs after the acquisition is stopped when reading a conditional state. This is equivalent to making a Stop Action selection in the Acquisition Setup dialog box.

Group

Acquisition

Related Commands

ACQUIRE:SAVEFile:SAVEScreen, ACQUIRE:SAVEFile:SAVEWfm

Syntax 1

ACQUIRE:STOPAFTER:ACTION {NONE|SAVEScreen
|PRINTScreen|SAVEWaveform}

Syntax 2

ACQUIRE:STOPAFTER:ACTION?

Arguments

- NONE
Specifies to take no action when the stop after condition is met. This is the default.

- **SAVEScreen**
Specifies that on acquisition stop the file named by the ACQUIRE:SAVEFile:SAVEScreen command will be created if it does not exist or overwritten if does. The resultant file will contain a bitmap image of the display.
- **PRINTScreen**
Specifies that on acquisition stop a bitmap image of the application is sent to the default printer.
- **SAVEWaveform**
Specifies that on acquisition stop all waveforms are saved in the files specified by the ACQUIRE:SAVEFile:SAVEWfm command.

Example 1

```
ACQUIRE:STOPAfter:ACTion PRINTSCREEN
```

Sets the instrument to send a bitmap image of the application to the printer when the stop after condition is met.

Example 2

```
ACQUIRE:STOPAfter:ACTion?
```

This query might return :ACQUIRE:STOPAFTER:ACTION NONE, indicating that no action is taken when the stop after condition is met.

ACQUIRE:STOPAfter:BELL

This command sets or queries whether to sound the bell after the acquisition is complete. This is equivalent to checking Ring Bell in the Stop Action section of the Acquisition Setup dialog box.

Group

Acquisition

Syntax 1

```
ACQUIRE:STOPAfter:BELL {ON|OFF|NR1}
```

Syntax 2

```
ACQUIRE:STOPAfter:BELL?
```

Arguments

- **ON**
Turns on the bell.
- **OFF**
Turns off the bell.
- **NR1**
0 turns off the bell; any other value turns on the bell.

Example 1

```
ACQUIRE:STOPAfter:BELL ON
```

This would turn on the Stop After Bell feature.

Example 2

```
ACQUIRE:STOPAFTER:BELL?
```

This query might return `:ACQUIRE:STOPAFTER:BELL 1`, indicating that the Stop After Bell feature is on.

NOTE: A query always returns a 0 or 1.

ACQUIRE:STOPAFTER:CONDITION

This command sets or queries the StopAfter condition. The StopAfter condition qualifies a stop condition for the acquisition system. Only one StopAfter condition can be active at a given time. Each StopAfter condition identifies, directly or indirectly, a specific data element or operation such that all mutually exclusive conditions are unique and unambiguous. This command allows you to specify the condition on which to stop acquiring. The condition is valid when the ACQUIRE:STOPAFTER:MODE is set to CONDITION. This is equivalent to checking the Condition control in the Stop After section of the Acquisition Setup dialog box and selecting a condition.

Note: You must have the associated feature enabled before you can set the StopAfter condition. For example, you must turn on histograms (HISTogram:ENABLE) before you can set the HISTHits StopAfter condition.

Group

Acquisition

Related Commands

ACQUIRE:STOPAFTER:COUNT, ACQUIRE:STOPAFTER:MODE

Syntax 1

```
ACQUIRE:STOPAFTER:CONDITION {ACQWfms|HISTWaveform  
|HISTHits|MASKWaveform|MASKSample|MASK<x>Hits  
|MASKTOTalhit|FRAMecycle|AVGComp}
```

Syntax 2

```
ACQUIRE:STOPAFTER:CONDITION?
```

Arguments

- ACQWfms
Sets the instrument to stop acquiring after some specified number of raw acquisition cycles. This setting tells the instrument to count the number of Main Timebase sweeps (Mag sweeps are not counted independently) and stop acquisition after the specified number of acquisitions has been reached. Use the ACQUIRE:STOPAFTER:COUNT command to set the target number of waveforms.
- HISTWaveform
Sets the instrument to stop acquisition after a specified number of Histogram source waveforms is acquired. Use the ACQUIRE:STOPAFTER:COUNT command to set the specified number of waveforms.
- HISTHits

Sets the instrument to stop acquisition after it acquires a specified number of valid hits (that is, non-null samples) in the histogram region. This is a greater than or equal to condition because only complete records are processed. Therefore, the number of actual hits will not necessarily match your requested number of hits; the acquisition will stop when the number of hits is greater than or equal to the number of specified hits. Use the `ACQUIRE:STOPAFTER:COUNT` command to set the specified number of hits.

- `MASKWaveform`
Sets the instrument to stop acquisition after a specified number of waveforms is acquired of the Mask source waveform. Use the `ACQUIRE:STOPAFTER:COUNT` command to set the specified number of waveforms.
- `MASKSample`
Sets the instrument to stop acquisition after a greater than or equal to number of valid (that is, non-null) waveform samples are acquired of the Mask source waveform. Use the `ACQUIRE:STOPAFTER:COUNT` command to set the specified number of waveform samples.
- `MASK<x>Hits`
Sets the instrument to stop acquisition after a specified number of mask hits occur in mask number `<x>`, which can be 1 through 8. For the same reasons as `HISTHits` argument, this is also a greater than or equal to condition. Use the `ACQUIRE:STOPAFTER:COUNT` command to set the specified number of hits.
- `MASKTOTALhit`
Sets the instrument to stop acquisition after a specified number of total mask hits occurs in all masks combined. For the same reasons as the `HISTHits` argument, this is also a greater than or equal to condition. Use the `ACQUIRE:STOPAFTER:COUNT` command to set the specified total number of hits.
- `FRAMecycle`
Sets the instrument to stop acquisition after it has acquired the number of bits specified in the Scan Bits field in the Frame Scan section of the Horizontal Setup dialog box (for example, stop after one frame scan cycle). You can set the number of scan bits with the `HORIZONTAL:FRAMESCAN:SCANBITS` command.
- `AVGComp`
Sets the instrument to stop acquisition after the number of waveforms specified by the `ACQUIRE:NUMAVG` command have been acquired and averaged.

Example 1

```
ACQUIRE:STOPAFTER:CONDITION HISTHits
```

This command sets the instrument to stop acquisition after it acquires the specified number of valid hits in the histogram region.

Example 2

ACQUIRE:STOPAFTER:CONDition?

This query might return :ACQUIRE:STOPAFTER:CONDition MASK3HITS, indicating that the acquisition will be stopped after the hits in mask 3 are equal to or greater than the specified number of hits.

ACQUIRE:STOPAFTER:COUNT

This command sets or queries the target StopAfter count for the condition specified by the ACQUIRE:STOPAFTER:CONDition command. The current count for the condition must be equal to or greater than this value before acquisitions are stopped and a StopAfter action is enabled. The state of the numeric StopAfter count for each condition is kept individually so that you do not need to re-enter a count when switching between conditions. Use the appropriate ACQUIRE:CURRENTcount command to get the current count for a condition (see *Related Commands* below).

Group

Acquisition

Related Commands

ACQUIRE:STOPAFTER:Mode, ACQUIRE:STOPAFTER:CONDition, ACQUIRE:CURRENTcount:ACQWfms?, ACQUIRE:CURRENTcount:HISTWfms?, ACQUIRE:CURRENTcount:HISTHits?, ACQUIRE:CURRENTcount:MASKWfms?, ACQUIRE:CURRENTcount:MASKHits?, ACQUIRE:CURRENTcount:MASKHits<x>?, ACQUIRE:CURRENTcount:MASKSamples?

Syntax 1

ACQUIRE:STOPAFTER:COUNT <NR1>

Syntax 2

ACQUIRE:STOPAFTER:COUNT?

Argument

NR1

This is the count value that must be reached (or exceeded) before the acquisitions stop and StopAfter action can occur.

Example 1

ACQUIRE:STOPAFTER:COUNT 12

This command sets the StopAfter count for the specified condition to 12.

Example 2

ACQUIRE:STOPAFTER:COUNT?

This query might return :ACQUIRE:STOPAFTER:COUNT 5, indicating that the total count for the specified condition is 5.

ACQUIRE:STOPAFTER:MODE

This command tells the instrument when to stop taking acquisitions. The query form of this command returns the StopAfter mode. This command is the equivalent of checking Run/Stop or Condition in the Stop After section of the Acquisition Setup dialog box. (The ACQUIRE:STATE command can also be used to start or stop acquisitions.)

Group

Acquisition

Related Commands

ACQUIRE:STOPAFTER:CONDITION, ACQUIRE:STATE

Syntax 1

```
ACQUIRE:STOPAFTER:MODE {RUNSTOP|CONDITION}
```

Syntax 2

```
ACQUIRE:STOPAFTER:MODE?
```

Arguments

- `RUNSTOP`
Specifies that the run and stop state is determined by the one of the front-panel RUN/STOP controls.
- `CONDITION`
Specifies that the run and stop state of the system is determined by a set of qualifiers specified by the StopAfter Condition. These sub-states are further described in the ACQUIRE:STOPAFTER:CONDITION section. (The instrument can still be stopped unconditionally by pressing the front-panel Run/Stop button or by sending the ACQUIRE:STATE command.)

Example 1

```
ACQUIRE:STOPAFTER:MODE RUNSTOP
```

This command sets the instrument to run or stop acquisitions when the user presses the front-panel RUN/STOP button.

Example 2

```
ACQUIRE:STOPAFTER:MODE?
```

This query might return `:ACQUIRE:STOPAFTER:MODE CONDITION`, indicating that the run and stop state of the system is determined by a set of qualifiers specified by the StopAfter condition.

ACQUIRE:STOPAFTER?

This query only command returns all StopAfter parameters.

Group

Acquisition

Syntax

```
ACQUIRE:STOPAFTER?
```

Example

```
ACQuire:STOPAfter?
```

```
This query might return :ACQUIRE:STOPAFTER:MODE
RUNSTOP;BELL 0;ACTION NONE;CONDITION
ACQWFMS;COUNT 1.
```

ACQuire?

This is a query only command that returns all the current acquisition parameters.

Group

Acquisition

Syntax

```
ACQuire?
```

Example

```
ACQuire?
```

This query might return the following string for the current acquisition parameters:

```
:ACQUIRE:CURRENTCOUNT:ACQWFMS 0;HISTWFMS
0;HISTHITS 0;MASKWFMS 0;MASKSAMPLES 0;MASKTHITS
0;MASKHITS1 0;MASKHITS2 0;MASKHITS3 0;MASKHITS4
0;MASKHITS5 0;MASKHITS6 0;MASKHITS7 0;MASKHITS8
0;:ACQUIRE:MODE SAMPLE;NUMAVG
16;SAVEFILE:SAVESCREEN "";SAVEWFM
"";:ACQUIRE:STATE 1;STOPAFTER:MODE RUNSTOP;BELL
0;ACTION NONE;CONDITION ACQWFMS;COUNT 1
```

ALLEv?

This query only command causes the instrument to return all events and their messages and removes the returned events from the Event Queue. The messages are separated by commas. Use the *ESR? query to enable the events to be returned. For a complete discussion of the use of these registers, see the topics in *Status and Events* on page 337. This command is similar to repeatedly sending *EVMsg? queries to the instrument.

Group

Status and Error

Related Commands

```
*CLS, DESE, *ESE, ESR?, EVENT?, EVMsg?, EVQty, *SRE, *STB?
```

Syntax

```
ALLEve?
```

Returns

The event code and message in the following format:

```
<Event Code>,<QString>[,<Event Code>,<QString>...]
<QString>::=<Message>;[<Command>]
```

<Command> is the command that caused the error and may be returned when a command error is detected by the instrument. As much of the command will be returned as possible without exceeding the 60-character limit of the <Message> and <Command> strings combined. The command string is right justified.

Example

ALLev?

This query might return the string :ALLEV 2225, "Measurement Error, No waveform to measure;", 420, "Query UNTERMINATED;".

AUTOSet

This command (no query form) causes the instrument to adjust its vertical, horizontal, and trigger controls to provide a stable display of the selected waveform. Sending this command is equivalent to pressing the front-panel AUTOSSET button.

Note: If the currently selected waveform is a mask source, a mask autoset will be performed.

Group

Miscellaneous

Related Commands

AUTOSet:TYPE

Syntax

AUTOSet EXECute

Argument

EXEcute

This argument autosets the currently selected waveform.

Example

AUTOSet EXECute

Autosets the currently selected waveform.

AUTOSet:STOP

This command (no query form) aborts an autoset that was initiated with the AUTOSet command.

Group

Miscellaneous

Syntax

AUTOSet : STOP

Example

AUTOSet : STOP

AUTOSet:TYPE

This command sets or queries the default mode used by the AUTOSet command to perform nonmask AUTOSet operations. Using the :TYPE argument, you can bias the autose operation for display of either a waveform edge, period, or eye, centered in the graticule. Sending this command is equivalent to selecting a mode in the Autose properties dialog box that is displayed when you select Define Autose from the Utilities menu.

Note. When performing MASK:AUTOSet operations, the currently defined predefined mask standard (selected with the MASK:STANDARD command) drives Autose execution, not the AUTOSet:TYPE command setting. However, when using a user-defined mask, you still might want to use the AUTOSet and AUTOSet:TYPE command, since the MASK:AUTOSet command is unable to obtain autose parameters from a user-defined mask standard.

Group

Miscellaneous

Related Commands

AUTOSet

Syntax 1

AUTOSet:TYPE {EDGE|PERIOD|EYE|RZ}

Syntax 2

AUTOSet:TYPE?

Arguments

- EDGE
Sets subsequent autose commands to configure the instrument to display a rising edge of the signal connected to the currently selected channel in the center 20% of the graticule.
- PERIOD
Sets subsequent autose commands to configure the instrument to display 2 to 3 periods of the signal connected to the currently selected channel centered in the graticule.
- EYE
Sets subsequent autose commands to configure the instrument to display one bit (two eye crossings) horizontally centered across approximately 70% of the graticule (7 divisions) and vertically centered across approximately 60% of the graticule (6 divisions). Use the Eye argument for NRZ waveforms.
- RZ
Sets subsequent autose commands to configure the instrument to display one bit (two rising edges) horizontally centered across approximately 60% of the graticule (6 divisions) and vertically centered across approximately 50% of the graticule (5 divisions).

Example 1

```
AUTOSet:TYPE EDGE
```

This command sets the default Autoset mode to EDGE.

Example 2

```
AUTOSet:TYPE?
```

This query might return :AUTOSET:TYPE RZ, indicating that the default Autoset mode is RZ.

AUTOSet:UNDO

This command (no query form) returns the parameters changed by an AUTOSet command to their previous states. This command is invalidated the first time you modify any instrument state parameter.

Group

Miscellaneous

Related Commands

AUTOSet

Syntax

```
AUTOSet:UNDO
```

Example 1

```
AUTOSet:UNDO
```

BUSY?

This is a query only command that returns the status of the instrument. This command allows you to synchronize the operation of the instrument with your application program. See *Synchronization Methods* on page 342 for more detailed information.

Group

Status and error

Related Commands

*OPC, *WAI

Syntax

```
BUSY?
```

Returns

```
<NR1>
```

If 0 is returned, it means that the instrument is not busy processing a command whose execution time is extensive. These commands are listed in the table below.

If 1 is returned, it means that the instrument is busy processing one of the commands listed in the table below.

Commands that Affect BUSY? Response	
Operation	Command
Automatic instrument adjustment	AUTOSet EXECute
Internal self compensation	COMPensate:ALL COMPensate:CH<x> COMPensate:DARKLev:CH<x> COMPensate:MAInframe COMPensate:OPTGAIN:CH<x>
Conditional	ACQuire:STATE ON or ACQuire:STATE RUN (when ACQuire:STOPAfter is set to CONDition)
Hardcopy output	HARDCopy START

Example

BUSY?

This query might return 1, indicating that the instrument is busy.

CALibrate:DATE:CH<x>?

Group

Calibration

Syntax

CALibrate:DATE:CH<x>?

Example

CALibrate:DATE:CH1?

This query might return :CALIBRATE:DATE:CH1 15 JAN 00 16:25, indicating that the last calibration update for the CH1 sampling module was done on January 15, 2000, at 4:25 PM.

CALibrate:DATE:MAInframe?

This query only command returns the date and time of the last calibration information update for the mainframe.

Group

Calibration

Syntax

CALibrate:DATE:MAInframe?

Example

CALibrate:DATE:MAInframe?

This query might return :CALIBRATE:DATE:MAINFRAME 15 JAN 00 16:25, indicating that the last calibration update for the mainframe was done on January 15, 2000, at 4:25 PM.

CALibrate:DCCALibrator

This command sets or queries the value of the DC Calibrator voltage.

Group

Calibration

Syntax 1

```
CALibrate:DCCALibrator <NR2>
```

Syntax 2

```
CALibrate:DCCALibrator?
```

Argument

NR2

This is the value to which you want to set the DC Calibrator voltage. The range for this value is from -1.25 VDC through $+1.25$ VDC.

Example 1

```
CALibrate:DCCALibrator 0.5
```

This command sets the DC Calibrator voltage to 0.5 V.

Example 2

```
CALibrate:DCCALibrator?
```

This query might return `:CALIBRATE:DCCALIBRATOR 5.000000000000E-001`, indicating that the DC Calibrator voltage is set to 0.5 V.

CALibrate:HOSTInfo:CH<x>?

This query only command returns the mainframe channel, model number, and serial number in which the sampling module channel was located during the last calibration information update.

Group

Calibration

Syntax

```
CALibrate:HOSTInfo:CH<x>?
```

Example

```
CALibrate:HOSTInfo:CH2?
```

This query might return `:CALIBRATE:HOSTINFO:CH2 "TDS8000,B010235,CH4"`, indicating that the sampling module currently in channel 2 was installed in channel 4 of the TDS8000 mainframe, serial number B010235 during the last calibration information update.

CALibrate:LOCK:STATus?

This is a query only command that returns the status of the calibration information hardware lock switch.

Group

Calibration

Syntax

CALibrate:LOCK:STATus?

Example

CALibrate:LOCK:STATus?

This query might return :CALibrate:LOCK:STATus 1, indicating that the calibration information is protected and cannot be updated.

CALibrate:STATus:CH<x>?

This is a query only command that returns the current calibration status for the sampling module channel.

Group

Calibration

Syntax

CALibrate:STATus:CH<x>?

Returns

May return PASS, DEFAULTS, or WARMUP.

Example

CALibrate:STATus:CH1?

This query might return :CALIBRATE:STATUS:CH1 PASS, indicating that the calibration status of the sampling module in channel 1 is PASS.

CALibrate:STATus:MAInframe?

This is a query only command that returns the current calibration status for the mainframe.

Group

Calibration

Syntax

CALibrate:STATus:MAInframe?

Returns

May return PASS, DEFAULTS, or WARMUP.

Example

CALibrate:STATus:MAInframe?

This query might return :CALIBRATE:STATUS:MAINFRAME PASS, indicating that the calibration status of the mainframe is PASS.

CALibrate:TEMPerature:CH<x>?

This is a query only command that returns the difference (in °C) between the current sampling module channel temperature and the temperature recorded at the last calibration information update.

Group

Calibration

Syntax

```
CALibrate:TEMPerature:CH<x>?
```

Example

```
CALibrate:TEMPerature:CH2?
```

This query might return `:CALIBRATE:TEMPERATURE:CH2 1.5`, indicating that the temperature difference between the current sampling module channel temperature and the temperature recorded at the last calibration information update is 1.5 °C.

CALibrate:TEMPerature:MAInframe?

This is a query only command that returns the difference (in °C) between the current mainframe temperature and the temperature recorded at the last calibration information update.

Group

Calibration

Syntax

```
CALibrate:TEMPerature:MAInframe?
```

Example

```
CALibrate:TEMPerature:MAInframe?
```

This query might return `:CALIBRATE:TEMPERATURE:MAINFRAME -2.7`, indicating that the difference in temperature between the current mainframe temperature and the temperature recorded at the last calibration information update is -2.7 °C

CALibrate:UPDATEinfo:ALL

This command (no query form) updates the calibration information for the mainframe and all resident sampling module channels into nonvolatile memories.

Note: The calibration lock switch must be set to Unprotected (that is, a query status of 0) for the calibration information to be updated.

Group

Calibration

Syntax

```
CALibrate:UPDATEinfo:ALL
```

Example

```
CALibrate:UPDATEinfo:ALL
```

CALibrate:UPDATEinfo:CH<x>

This command (no query form) updates the calibration information in the nonvolatile memory of the sampling module. This includes the current date and time, temperature, and host information (such as current channel, location, model number, and serial number).

Note: The calibration lock switch must be set to Unprotected (that is, a query status of 0) for the calibration information to be updated.

Group

Calibration

Syntax

```
CALibrate:UPDATEinfo:CH<x>
```

Example

```
CALibrate:UPDATEinfo:CH1
```

CALibrate:UPDATEinfo:MAInframe

This command (no query form) updates the calibration information in the nonvolatile memory of the mainframe. This includes the current date, time, and temperature.

Note: The calibration lock switch must be set to Unprotected for the calibration information to be updated.

Group

Calibration

Syntax

```
CALibrate:UPDATEinfo:MAInframe
```

Example

```
CALibrate:UPDATEinfo:MAInframe
```

CH<x>:BANdwidth:LIST?

This query-only command returns a list of the available bandwidths for the specified channel. The channel is specified by x, which can be 1 through 8. (Generally, bandwidth selections are available only to optical sampling modules in CH 1 or CH 2.) The returned list contains the actual bandwidths available for the channel. The available bandwidths are dependent on the optical sampling module.

The optical modules have differing valid settings. Use the <>:LIST? query to determine the valid {Clock Recovery | Filter | Bandwidth | Wavelength} settings for your optical module. Features of optical modules are listed in the *80C0X Optical Module User Manual*. Features of currently installed optical modules can be viewed using the System Properties dialog.

To set the bandwidth for a channel, use the CH<x>:BANDwidth:VALue command.

Group

Vertical

Related Commands

CH<x>:BANDwidth:VALue

Syntax

CH<x>:BANDwidth:LIST?

Example

CH1:BANDwidth:LIST?

This query might return :CH1:BANDWIDTH:LIST
20.0000000000E+009,12.49999974400E+009, which indicates the bandwidths that are available for Channel 1 (80C01 Optical Sampling Module).

CH<x>:BANDwidth:VALue

This command sets or queries the bandwidth for the channel specified by x, which can be 1 through 8. (Generally, bandwidth selections are available only to optical sampling modules in CH 1 or CH 2.) Sending the command is the equivalent to selecting a bandwidth from the Bandwidth pulldown menu in the Signal Conditioning section of the Vertical Setup dialog box for Optical. The available bandwidths are determined by the optical sampling module.

The optical modules have differing valid settings. Use the <>:LIST? query to determine the valid {Clock Recovery | Filter | Bandwidth | Wavelength} settings for your optical module. Features of optical modules are listed in the *80C0X Optical Module User Manual*. Features of currently installed optical modules can be viewed using the System Properties dialog.

Available bandwidths include the following: 2 GHz, 12.5 GHz, 20 GHz, 30 GHz, 40 GHz, and 50 GHz.

You can use the CH<x>:BANDwidth:LIST? query to determine the available bandwidths for the specified channel.

Group

Vertical

Syntax 1

CH<x>:BANDwidth:VALue <NR3>

Syntax 2

CH<x>:BANDwidth:VALue?

Arguments

NR3

This argument is the value of the bandwidth you want to set. Use the CH<x>:BANDwidth:LIST? command to query the bandwidths available

for the specified channel. The instrument automatically selects the bandwidth nearest to the input value.

Example 1

```
CH1:BAWdwidth:VALue 2.0E+10
```

This argument sets the Channel 1 bandwidth to 20 GHz.

Example 2

```
CH2:BAWdwidth:VALue?
```

This query might return :CH2:BAWdwidth:VALUE

12.49999974400E+009, indicating that the bandwidth for Channel 1 is set to 12.5 GHz.

CH<x>:DESkew

This command sets or queries the deskew time for the channel specified by x, which can be 1 through 8. Sending this command is the equivalent to setting Deskew in the Vertical Setup dialog box for the selected channel.

You can adjust deskew to add or subtract an independent, channel-based acquisition time delay to the delay from the trigger point (the horizontal position) that is inherently common to the acquisition of all channels. This allows you to compensate for delay differences introduced between channels by external cabling with unequal delays.

Note: Setting different deskew values on dual-channel sampling modules that use a single sampling strobe (for example, the 80E02, 80E03, 80E04 sampling modules) reduces overall acquisition performance. In these instances, the acquisition must digitize each channel on a separate acquisition pass to obtain each of the signals with the desired time alignment. This multiple pass acquisition process applies to the acquisition of the channels within each active timebase.

Group

Vertical

Syntax 1

```
CH<x>:DESkew <NR3>
```

Syntax 2

```
CH<x>:DESkew?
```

Argument

NR3

This is the deskew time for this channel. The range is -0.5 ns to +100 ns with a resolution of 1 ps. Out of range values are clipped.

Example 1

```
CH7:DESkew 5.0E-9
```

This command sets the deskew time for Channel 7 to 5 ns.

Example 2

```
CH3:DESkew?
```

This query might return :CH3:DESKEW 10.00000000008E-009, indicating that the deskew time for Channel 3 is set to 10 ns.

CH<x>:EXTAtten:MODE

This command sets or queries the external attenuation mode for the channel specified by x, which can be 1 through 8.

Group

Vertical

Syntax 1

CH<x>:EXTAtten:Mode {LINear|DB}

Syntax 2

CH<x>:EXTAtten:MODE?

Arguments

- LINear
This argument sets the mode so that the attenuation value is a linear numeric multiplier, such as 15X.
- DB
This argument sets the mode so that the attenuation value is in dB.

Example 1

CH7:EXTAtten:MODE LIN

This command sets the external attenuation mode to linear for the Channel 7.

Example 2

CH3:EXTAtten:MODE?

This query might return :CH3:EXTATTEN:MODE DB, indicating that the external attenuation is set to the DB mode for Channel 3.

CH<x>:EXTAtten:VALue

This command sets a value matching the amount of attenuation applied externally, before the signal enters the specified input channel. The channel is specified by x, which can be 1 through 8. The query form returns the amount of attenuation that is set for the instrument. The instrument takes into account this external attenuation when displaying vertical readouts, measurements, and so on for this channel. This command is the equivalent to entering a value in the External Attenuation control in the External Attenuation section of the Vertical Setup dialog box.

Use the CH<x>:EXTAtten:MODE command to select whether the attenuation value is set or returned as a linear attenuation (such as 15X) or as dB attenuation (such as 10 dB).

*Note: External Attenuation (dB) = 20 * log10 (Linear) for External Attenuation (linear) > 0.*

For example, 0 dB=1X, 20 dB=10X, 40 dB=100X, and so on.

The external attenuation is set to 1 (linear) or 0 dB for all TDR sources and for all channels released as TDR sources. External attenuation is set to 1 (linear) or 0 dB when you attach an external real-time accessory, such as a probe, to the selected channel.

Group

Vertical

Related Command

CH<x>:EXTAtten:MODE

Syntax 1

CH<x>:EXTAtten:VALue <NR3>

Argument

NR3

This is the attenuation value specified as a multiplier in the range of 1.0E-6 to 1.0E+6. The default is 1.00.

Syntax 2

CH<x>:EXTAtten:VALue?

Example 1

CH7:EXTAtten:VALue 1.5E+1

This command sets the external attenuation for Channel 7 to 15X when linear is set as the external attenuation mode.

Example 2

CH3:EXTAtten:VALue?

This query might return :CH3:EXTATTEN:VALUE

10.000000000000, indicating that the external attenuation is set to 10X for Channel 3 when linear is set as the external attenuation mode.

CH<x>:FILTer:LIST?

This query only command returns a list of the filters available for the channel specified by x, which can be 1 through 8. (Generally, only optical modules in CH1 or CH2 have filter selections.) The filters available depend on the optical sampling module (see the *80C0X Optical Sampling Module User Manual*). Sending this command is the equivalent using the Filter pulldown in the Signal Conditioning section of the Optical portion of the Vertical Setup dialog box.

Use the CH<x>:FILTer:VALue command to set a filter.

Group

Vertical

Related Commands

CH<x>:FILTer:VALue

Syntax

CH<x>:FILTer:LIST?

Example

```
CH1:FILTer:LIST?
```

This query might return : CH1 : FILTER : LIST

NONE, OC12, OC48, OC192, indicating the filters available for Channel 1 when using an 80C01 Optical Sampling Module.

CH<x>:FILTer:VALue

This command sets or queries the reference-receiver filter that is applied to the channel specified by x, which can be 1 through 8. The reference-receiver filter selections require hardware support that may not be provided by your sampling module; see your 8000-series sampling module user manual to determine which filters your module supports. You can also use the CH<x>:FILTer:LIST? query to return a list of the filters available for the specified channel.

If you select a filter that your sampling module does not support, you will receive Execution Error code 2508, with error message "Selected filter is not available". (See *Messages*, on page 347, for general information on programming interface messages.)

Group

Vertical

Related Commands

```
CH<x>:FILTer:LIST?
```

Syntax 1

```
CH<x>:FILTer:VALue {NONE|OC1|OC3|OC9|OC12|OC18|OC24  
|OC36|OC48|FEC2666|OC96|OC192|FEC10664|FEC10709  
|FC1063|FC2125|FC4250|ENET1250|ENET3125|ENET9953  
|ENET10313|INFIniband}
```

Syntax 2

```
CH<x>:FILTer:VALue?
```

Arguments

- NONE
Disables reference- receiver filtering.
- OC1
Selects a reference-receiver filter for the 51.84 Mb/s bit rate, in accordance with the Sonet/SDHOC-1/STM-0 standard.
- OC3
Selects a reference-receiver filter for the 155.52 Mb/s bit rate, in accordance with the Sonet/SDHOC-3/STM-1 standard.
- OC9
Selects a reference-receiver filter for the 466.56 Mb/s bit rate, in accordance with the Sonet/SDHOC-9/STM-3 standard.
- OC12
Selects a reference-receiver filter for the 622.08 Mb/s bit rate, in

accordance with the Sonet/SDHOC-12/STM-4 standard.

- OC18
Selects a reference-receiver filter for the 933.12 Mb/s bit rate, in accordance with the Sonet/SDHOC-18/STM-6 standard.
- OC24
Selects a reference-receiver filter for the 1.24416 Gb/s bit rate, in accordance with the Sonet/SDHOC-24/STM-8 standard.
- OC36
Selects a reference-receiver filter for the 1.86624 Gb/s bit rate, in accordance with the Sonet/SDHOC-36/STM-12 standard.
- OC48
Selects a reference-receiver filter for the 2.48832 Gb/s bit rate, in accordance with the Sonet/SDHOC-48/STM-16 standard.
- FEC2666
Selects a reference-receiver filter for the 2.6660571 Gb/s bit rate, in accordance with the ITU-T G.975 Recommendation
- OC96
Selects a reference-receiver filter for the 4.97664 Gb/s bit rate, in accordance with the Sonet/SDHOC96/STM-32 standard.
- OC192
Selects a reference-receiver filter for the 9.95328 Gb/s bit rate, in accordance with the Sonet/SDHOC192/STM-64 standard.
- FEC10664
Selects a reference-receiver filter for the 10.6642 Gb/s bit rate, in accordance with the ITU-T G.975 recommendation.
- FEC10709
Selects a reference-receiver filter for the 10.709225 Gb/s bit rate, in accordance with the ITU-T G.709 draft recommendation.
- FC1063
Selects a reference-receiver filter for the 1.0625 Gb/s bit rate, in accordance with the ANSI X3.230-1994 standard.
- FC2125
Selects a reference-receiver filter for the 2.125 Gb/s bit rate, in accordance with the ANSI Fibre Channel Physical Interface (FC-PI) Rev 11 draft standard.
- FC4250
Selects a reference-receiver filter for the 4.250 Gb/s bit rate, in accordance with the ANSI Fibre Channel Physical Interface (FC-PI) Rev 11 draft standard.
- ENET1250
Selects a reference-receiver filter for the 1.250 Gb/s bit rate, in

accordance with the IEEE 802.3 standard.

- ENET3125
Selects a reference-receiver filter for the 3.125 Gb/s bit rate, in accordance with the IEEE P802.ae draft standard.
- ENET9953
Selects a reference-receiver filter for the 9.9533 Gb/s bit rate, in accordance with the IEEE P802.ae draft standard.
- ENET10313
Selects a reference-receiver filter for the 10.313 Gb/s bit rate, in accordance with the IEEE P802.ae draft standard.
- INFIniband
Selects a reference-receiver filter for the 2.500 Gb/s bit rate, in accordance with the InfiniBand standard.

Example 1

```
CH1:FILTer:VALue NONe
```

This command disables the filtering for Channel 1.

Example 2

```
CH2:FILTer:VALue?
```

This query might return :CH2:FILTER:VALUE OC12, indicating that the OC12 filter is enabled for Channel 2.

CH<x>:OFFSet

This command sets or queries the vertical offset for the specified channel. The channel is specified by x, which can be 1 through 8. Setting an offset with this command is the equivalent to entering a value in the Offset control in the Channel section of the Vertical Setup dialog box or adjusting the front-panel Vertical OFFSET knob.

Channel offset adjusts the vertical acquisition window (moves the DC level around which the signal is sampled) for the selected channel. Visualize offset as scrolling the acquisition window towards the top of a large signal (or one with a positive DC bias) for increased offset values and scrolling towards the bottom for decreased offset values. Optimal vertical accuracy (of the entire signal) is obtained when the offset is set to the average DC bias of the input signal (that is, when it centers the signal around the input dynamic range of the sampling module).

The range and resolution of offset values for a given channel is dependent on multiple factors: the sampling module type (specifically, its input dynamic range), the probe type (if attached), the external attenuation factor, the selected units (if TDR is active), and the scale.

For more information on how offset ranges are determined, refer to the topic Vertical Offset in the online help for your instrument.

Group

Vertical

Related Commands

CH<x>:POSition

Syntax 1

CH<x>:OFFSet <NR3>

Syntax 2

CH<x>:OFFSet?

Argument

NR3

This is the offset value for the specified channel; the range is ± 1.6 V.

Example 1

CH4:OFFSet 2.0E-3

This sets the offset for Channel 4 to 2 mV.

Example 2

CH3:OFFSet?

This query might return :CH3:OFFSET 0.100000000000, indicating that the offset for Channel 3 is set to 100 mV.

CH<x>:POSition

This command sets or queries the vertical position of the specified channel. The channel is specified by x, which can be 1 through 8. Sending this command is the equivalent to setting Position in the Setup section of the Vertical Setup dialog box or adjusting the front-panel Vertical POSITION knob.

Increasing the position value of a waveform causes the waveform to move up, and decreasing the position value causes the waveform to move down. Position adjusts only the display position of a channel, math, or reference waveform.

Group

Vertical

Related Commands

CH<x>:OFFSet

Syntax 1

CH<x>:POSition <NR3>

Syntax 2

CH<x>:POSition?

Argument

<NR3>

This is the position value in divisions from the center graticule. The range is ± 5 divisions for channels and ± 1000 divisions for math and reference waveforms.

Example 1

```
CH2:POSITION 1.3E+00
```

Positions the Channel 2 input signal 1.3 divisions above the center graticule.

Example 2

```
CH1:POSITION?
```

This command might return `:CH1:POSITION -2.000000000000`, indicating that the current position of Channel 1 is 2 divisions below the center graticule.

CH<x>:SCALE

This command sets or queries the vertical scale of the channel specified by *x*, which can be 1 through 8. Sending this command is the equivalent to setting a value in the Scale control in the Setup section of the Vertical Setup dialog box or adjusting the front-panel Vertical SCALE knob.

Channel scale, expressed as the per division setting, adjusts the display size for the selected channel. Similar to the scale control for reference and math waveforms, this control provides graphical scaling only; the control has no effect on the input vertical acquisition hardware.

Increasing the scale causes the waveform to be displayed smaller.

Decreasing the scale causes the waveform to be displayed larger.

The range and resolution of scale values for a given channel is dependent on multiple factors: the sampling module type (specifically, its input dynamic range), the probe type (if attached), the external attenuation factor, and the selected units (if TDR is active).

For more information on how scale ranges are determined, refer to the topic Vertical Scale in the online help for your instrument.

Channel scale changes have an effect on the allowable offset range for the channel. In general, as the vertical scale value is reduced, the amount of allowable offset increases.

For more information on how scale affects offset range, refer to the topic Vertical Offset in the online help for your instrument.

Group

Vertical

Related Commands

CH<x>:OFFSet, CH<x>:POSition

Syntax 1

```
CH<x>:SCALE <NR3>
```

Syntax 2

```
CH<x>:SCALE?
```

Argument

NR3

This is the vertical channel scale in units per division.

Example 1

```
CH4:SCALE 5.0E-01
```

This command sets the scale for Channel 4 to 500 mV per division.

Example 2

```
CH2:SCALE?
```

This query might return `:CH2:SCALE 0.020000000000`, indicating that the current scale setting of Channel 2 is 20 mV per division.

CH<x>:UNIts

This command sets or queries the units for the specified channel. The channel is specified by *x*, which can be 1 through 8. Sending this command is the equivalent to setting the Units control in the Channel section of the Vertical Setup dialog box. You can use this control to override the automatic selection of units for the selected channel. If you set this value to `AUTO`, the instrument automatically selects the units. If you set this value to `Volt`, `Watt`, or `Amp`, the instrument will apply these units to the vertical axis.

- The selections in this control are Auto, Volt, Amp, and Watt. When you change the units setting, all vertical units are reported as specified and no data transformations take place.
- For TDR waveforms, the Units control in the Vertical Setup dialog box is not active. Use the `TDR:CH<x>:UNIts` command to set and query units in TDR. The units available are Rho, Ohm, and Volt. When you change units of TDR waveforms, data transformations take place. The default is Rho.

Group

Vertical

Syntax 1

```
CH<x>:UNIts {AUTO|Volt|Watt|Amp}
```

Syntax 2

```
CH<x>:UNIts?
```

Arguments

- `AUTO`
This sets the units for the specified channel so that they are automatically determined by the instrument (depends on the probe attached to the specified channel).
- `Volt`
This sets the vertical-axis units for the specified channel to volts.
- `Watt`
This sets the vertical-axis units for the specified channel to watts.
- `Amp`
This sets the vertical-axis units for the specified channel to amperes.

Example 1

```
CH4:UNIts AUTO
```

This command sets the vertical axis units for Channel 4 so that they are determined automatically by the instrument.

Example 2

```
CH1:UNITs?
```

This query might return `:CH1:UNITS VOLT`, indicating that the vertical-axis units for Channel 1 are set to volts.

CH<x>:WFMLabel

This command sets or queries the label associated with the channel waveform specified.

Group

Vertical

Related Commands

Math<x>:WFMLabel, REF<x>:WFMLabel

Syntax 1

```
CH<x>:WFMLabel
```

Syntax 2

```
CH<x>:WFMLabel?
```

Argument

Qstring

This argument sets the label for the waveform.

Example 1

```
CH1:WFMLabel "My CH1 waveform"
```

This command sets the label for CH1 to be "My CH1 waveform," which is the label displayed with the waveform when it is displayed on screen.

Example 2

```
CH1:WFMLabel?
```

This query might return `:CH1:WFMLABEL "My CH1 waveform"` indicating that the label for channel 1 is set to "My CH1 waveform."

CH<x>:WLENgth:LIST?

This query only command returns a list of the available wavelengths for the channel specified by x, which can be 1 through 8. (Generally, only optical modules in CH1 or CH2 have wavelength selections.) The returned list contains the actual wavelengths available for the channel. Use the `CH<x>:WLENgth:VALue` command to set a value from the list.

Group

Vertical

Related Commands

CH<x>:WLENgth:VALue

Syntax

CH<x>:WLENgth:LIST?

Example

CH2:WLENgth:LIST?

This query might return :CH2:WLENLIST
FACTORY, 1550, 1310, USER, 1330, indicating the available
wavelengths for Channel 2.

CH<x>:WLENgth:VALue

This command sets or queries the wavelength for the channel specified by x, which can be 1 through 8. (Generally, only optical modules in CH1 or CH2 have filter selections.) You can use the CH<x>:WLENgth:LIST? query to determine the available wavelengths.

Group

Vertical

Related Commands

CH<x>:WLENgth:LIST?

Syntax 1

CH<x>:WLENgth:VALue <NR3> [,USER|FACTory]

Syntax 2

CH<x>:WLENgth:VALue?

Arguments

- NR3
This argument specifies the wavelength.
- USER
This keyword must follow a user-calibrated value.
- FACTory
This argument must follow a factory-calibrated value.

Example 1

CH1:WLENgth:VALue 1310

This argument sets the Channel 1 wavelength to 1310.

Example 2

CH2:WLENgth:VALue?

This query might return :CH2:WLENGTH:VALUE 1550, indicating
that the wavelength for Channel 2 is set to 1550.

CH<x>?

This is a query only command that returns the vertical parameters for the specified channel. The channel is specified by x, which can be 1 through 8.

Group

Vertical

Syntax

CH<x>?

Example

CH3?

This query might return the following:

```
:CH3:DESKEW 0.000000000000;OFFSET
0.000000000000;UNITS AUTO;FILTER:VALUE NONE;
:CH3:EXTATTEN:MODE LINEAR;VALUE 1.000000000000;
:CH3:POSITION 0.000000000000;
PTPEAK 0.700000000000;SCALE 0.700000000000
```

COMPensate:ALL

This command (no query form) compensates the mainframe and all resident sampling module channels for DC variances. Before sending this command, disconnect or terminate all sampling module inputs, and disconnect all probes.

Note: Data from a successful compensation is not automatically saved into nonvolatile user storage. Use the COMPensate:SAVE commands if you want to retain the data in nonvolatile storage.

Group

Compensation

Related Commands

COMPensate:SAVe:USER:ALL

Syntax

COMPensate:ALL

Example

COMPensate:ALL

COMPensate:CH<x>

This command (no query form) compensates the sampling module channel for DC variances. Before sending this command, disconnect or terminate all sampling module inputs, and disconnect all probes.

Note: Data from a successful compensation is not automatically saved into nonvolatile user storage. Use the COMPensate:SAVE commands if you want to retain the data in nonvolatile storage.

Group

Compensation

Related Commands

COMPensate:SAVe:USER:CH<x>

Syntax

COMPensate:CH<x>

Example

COMPensate:CH1

COMPensate:DARKLev:CH<x>

This command (no query form) compensates an optical channel by removing residual DC offsets in the entire vertical path. This provides better DC offset compensation at the current vertical settings. Before sending this command, disconnect the input to the optical channel (or turn off the optical source) so there is no optical signal (that is, it is "dark").

Group

Compensation

Syntax

COMPensate:DARKLev:CH<x>

Example

COMPensate:DARKLev:CH1

COMPensate:DATE:CH<x>?

This is a query only command that returns the date and the time of the current in-use (that is, run-time) compensation data for the sampling module channel.

Group

Compensation

Syntax

COMPensate:DATE:CH<x>?

Example

COMPensate:DATE:CH2?

This query might return :COMPENSATE:DATE:CH2 15 JAN 00
16:25.

COMPensate:DATE:MAInframe?

This is a query only command that returns the date and the time of the current in-use (that is, run-time) compensation data for the mainframe.

Group

Compensation

Syntax

COMPensate:DATE:MAInframe?

Example

COMPensate:DATE:MAInframe?

This query might return :COMPENSATE:DATE:MAINFRAME 15
JAN 00 16:25.

COMPensate:MAInframe

This command (no query form) compensates the mainframe for DC variances. Before sending this command, disconnect or terminate all sampling module inputs, and disconnect all probes.

Note: Data from a successful compensation is not automatically saved into nonvolatile user storage. Use the COMPensate:SAVE commands if you want to retain the data in nonvolatile storage.

Group

Compensation

Related Commands

COMPensate:SAVE:USER:MAInframe

Syntax

COMPensate:MAInframe

Example

COMPensate:MAInframe

COMPensate:OPTGAIN:CH<x>

This command (no query form) compensates the gain of the optical channel by comparing the given input power to an average optical power measurement. The gain correction factor and the given input wavelength are automatically stored in the nonvolatile memory of the sampling module channel. The optical signal source must be connected and configured appropriately before sending this command. You should use a signal of known optical power at the wavelength for which you are compensating.

Group

Compensation

Syntax

COMPensate:OPTGAIN:CH<x> <NR1>, <NR3>

Arguments

- NR1
This argument is the wavelength (in nm) of the input optical signal.
- NR3
This argument is the average optical power of the input optical signal.

Example

COMPensate:OPTGAIN:CH1 1000,1.0E-3

COMPensate:RECAI:FACTory:ALL

This command (no query form) recalls compensation data for the mainframe and all resident sampling module channels from their respective nonvolatile factory memories into the current, in-use (that is, run-time) compensation memory.

Group

Compensation

Syntax

COMPensate:RECAI:FACTory:ALL

Example

COMPensate:RECAI:FACTory:ALL

COMPensate:RECAI:FACTory:CH<x>

This command (no query form) recalls compensation data from the nonvolatile factory memory of the sampling module channel into its associated in-use (that is, run-time) compensation memory.

Group

Compensation

Syntax

COMPensate:RECAI:FACTory:CH<x>

Example

COMPensate:RECAI:FACTory:CH2

COMPensate:RECAI:FACTory:MAInframe

This command (no query form) recalls compensation data from the nonvolatile factory memory of the mainframe into its associated in-use (that is, run-time) compensation memory.

Group

Compensation

Syntax

COMPensate:RECAI:FACTory:MAInframe

Example

COMPensate:RECAI:FACTory:MAInframe

COMPensate:RECAI:USER:ALL

This command (no query form) recalls compensation data for the mainframe and all resident sampling module channels from their respective nonvolatile user memories into the current, in-use (that is, run-time) compensation memory.

Group

Compensation

Syntax

COMPensate:RECA11:USER:ALL

Example

COMPensate:RECA11:USER:ALL

COMPensate:RECA11:USER:CH<x>

This command (no query form) recalls compensation data from the nonvolatile user memory of the sampling module channel into its associated in-use (that is, run-time) compensation memory.

Group

Compensation

Syntax

COMPensate:RECA11:USER:CH<x>

Example

COMPensate:RECA11:USER:CH1

COMPensate:RECA11:USER:MAInframe

This command (no query form) recalls compensation data from the nonvolatile user memory of the mainframe into its associated in-use (that is, run-time) compensation memory.

Group

Compensation

Syntax

COMPensate:RECA11:USER:MAInframe

Example

COMPensate:RECA11:USER:MAInframe

COMPensate:RESults:VERBose?

This is a query only command that returns a more explanatory message than the COMPensate:ReSults query returns about the results of the last compensation execution.

Group

Compensation

Related Commands

COMPensate:RESults?

Syntax

COMPensate:RESults:VERBose?

Example

COMPensate:RESults:VERBose?

This query might return : COMPENSATE:RESULTS:VERBOSE
COMP COMPLETED, NO FAILURES.

COMPensate:RESults?

This is a query only command that returns an abbreviated status about the results of the last compensation execution. Any result other than PASS generally indicates a failure. For a more detailed message about the results of the last compensation execution, use the COMPensate:RESults:VERBose? query.

Group

Compensation

Syntax

COMPensate:RESults?

Example

COMPensate:RESults?

This query might return : COMPENSATE:RESULTS PASS, indicating that the compensation was successful.

COMPensate:SAVe:USER:ALL

This command (no query form) saves the volatile run-time compensation data for the mainframe and all resident sampling module channels into their respective nonvolatile user memories.

Group

Compensation

Syntax

COMPensate:SAVe:USER:ALL

Example

COMPensate:SAVe:USER:ALL

COMPensate:SAVe:USER:CH<x>

This command (no query form) saves the volatile run-time compensation data for the sampling module channel into the nonvolatile user memory of the sampling module channel. The channel is specified by x, which can be 1 through 8.

Group

Compensation

Syntax

COMPensate:SAVe:USER:CH<x>

Example

COMPensate:SAVe:USER:CH2

COMPensate:SAVe:USER:MAInframe

This command (no query form) saves the volatile run-time compensation data for the mainframe into the nonvolatile user memory of the mainframe.

Group

Compensation

Syntax

COMPensate:SAVe:USER:MAInframe

Example

COMPensate:SAVe:USER:MAInframe

COMPensate:STATus:CH<x>?

This is a query only command that returns the current compensation status for the sampling module channel. Possible responses are DEFAULTS, WARMUP, FAIL, PASS, and COMPREQ.

Group

Compensation

Syntax

COMPensate:STATus:CH<x>?

Example

COMPensate:STATus:CH1?

This query might return :COMPENSATE:STATUS:CH1 COMPREQ, indicating that the warm-up period for the instrument has elapsed, but the current compensation temperature delta is greater than desired, and the instrument should be compensated again.

COMPensate:STATus:MAInframe?

This is a query only command that returns the current compensation status for the mainframe. Possible responses are DEFAULTS, WARMUP, FAIL, PASS, and COMPREQ.

Group

Compensation

Syntax

COMPensate:STATus:MAInframe?

Example

COMPensate:STATus:MAInframe?

This query might return :COMPENSATE:STATUS:MAINFRAME PASS, indicating that the current compensation data should allow the instrument to meet operating specifications.

COMPensate:TEMPerature:CH<x>?

This query only command returns the difference (in °C) between the current temperature of the sampling module channel and the associated temperature currently residing in the in-use run-time compensation memory.

Group

Compensation

Syntax

COMPensate:TEMPerature:CH<x>?

Example

COMPensate:TEMPerature:CH1?

This query might return :COMPENSATE:TEMPERATURE:CH1 1.5

COMPensate:TEMPerature:MAInframe?

This query only command returns the difference (in °C) between the current temperature of the mainframe and the associated temperature currently residing in the in-use run-time compensation memory.

Group

Compensation

Syntax

COMPensate:TEMPerature:MAInframe?

Example

COMPensate:TEMPerature:MAInframe?

This query might return

:COMPENSATE:TEMPERATURE:MAINFRAME 2.7.

CURSor:CURSor<x>:COLOR

This command sets or queries the color of the cursor specified by x, which can be 1 or 2. (This command is the same as the DISPLAY:COLor:CURSOR command.) This is equivalent to setting Color in the Cursor 1 or Cursor 2 section of the Cursor Setup dialog box. The available colors are listed in the following table.

Available Cursor Colors		
Example	Name	Index Number
	Black	0
	Blue	1
	Aqua	2
	Lime	3
	Fuchsia	4
	Red	5
	Yellow	6
	White	7
	Navy	8
	Teal	9
	Green	10
	Purple	11
	Maroon	12
	Olive	13
	Gray	14
	Silver	15

Group

Cursor

Related Commands

DISPlay:COLor:CURSOR

Syntax 1

CURSor:CURSOR<x>:COLOR <NR1>

Syntax 2

CURSor:CURSOR<x>:COLOR?

Argument

NR1

NR1 is an integer in the range of 0 through 15 representing a color as defined in the above table.

Example 1

CURSor:CURSOR2:COLOR 5

This command sets the color of Cursor 2 to red.

Example 2

CURSor:CURSOR1:COLOR?

This query might return :CURSOR:CURSOR1:COLOR 9, indicating that the color of Cursor 1 is Teal

CURSor:CURSor<x>:SOUrce

This command sets or queries which waveform is associated with the specified cursor. The cursor is specified by x, which can be 1 or 2. This command can optionally set the target timebase. This is equivalent to selecting a waveform (and timebase) in the Source control for the Cursor 1 or Cursor 2 section of the Cursor Setup dialog box. If you do not set the timebase, the default is Main for both cursors.

Group

Cursor

Syntax 1

```
CURSor:CURSOR<x>:SOUrce {CH<x>|MATH<x>|REF<x>}  
[ , {MAIN|MAG1|MAG2} ]
```

Syntax 2

```
CURSor:CURSOR<x>:SOUrce?
```

Arguments

- CH<x>
This argument selects a channel waveform as the source for the specified cursor. The range for x is 1 through 8.
- MATH<x>
This argument selects a math waveform as the source for the specified cursor. The range for x is 1 through 8.
- REF<x>
This argument selects a reference waveform as the source for the specified cursor. The range for x is 1 through 8.
- MAIn
This optional argument selects Main as the timebase for the specified cursor display.
- MAG1
This optional argument selects MAG1 as the timebase for the specified cursor display.
- MAG2
This optional argument selects MAG2 as the timebase for the specified cursor display.

Example 1

```
CURSor:CURSOR2:SOUrce CH8,MAG1
```

This command associates Cursor 2 with the channel 8 waveform and the MAG1 timebase.

Example 2

```
CURSor:CURSOR1:SOUrce?
```

This query might return `:CURSOR:CURSOR1:SOURCE REF2,MAIN` indicating that Cursor 1 is associated with the REF2 waveform and the Main timebase.

CURSor:FUNction

This command sets or queries cursor type. Cursors are attached to the selected waveform. Sending this command is equivalent to setting Function in the Cursor Setup dialog box.

Group

Cursor

Related Command

SElect:CONTROL

Syntax 1

```
CURSor:FUNction {HBArS|OFF|VBArS|WAVEforms}
```

Syntax 2

```
CURSor:FUNction?
```

Arguments

- **HBArS**
Enables horizontal bar cursors, which provide traditional vertical unit readouts for Cursor 1 (bar1), Cursor 2 (bar2), and the Δ between them.
- **OFF**
Removes the cursors from the display.
- **VBArS**
Enables vertical bar cursors, which provide traditional horizontal unit readouts for Cursor 1 (bar1), Cursor 2 (bar2), the Δ between them, and $1/\Delta t$ (frequency when the horizontal unit is time).
- **WAVEforms**
Enables the waveform cursors, which provide both horizontal unit readouts and vertical unit readouts for Cursor 1 and Cursor 2, which are constrained to valid data points of the selected waveform.

Example 1

```
CURSOR:FUNCTION VBARS
```

This command enables the vertical bar type cursors.

Example 2

```
CURSOR:FUNCTION?
```

This query might return `:CURSOR:FUNCTION HBARS`, indicating that the horizontal bar cursors are enabled.

CURSor:HBARS:DELTA?

This query only command returns the difference between the two horizontal bar cursors.

Group

Cursor

Related Commands

CURSor:FUNCtion

Syntax

CURSor:HBARS:DELTA?

Returns

NR3

Example

CURSOR:HBARS:DELTA?

This command might return :CURSOR:HBARS:DELTA -
3.00813008130E-003 for the difference between the two horizontal
bar cursors.

CURSor:HBARS:POStion<x>

This command sets or queries the position of a horizontal bar cursor, which is constrained to be visible in the selected timebase. (Use the CURSor:FUNCtion command to set the cursor function to horizontal bars.) The cursor is specified by x, which can be 1 or 2. This is equivalent to setting a value in the Position control in the Cursor 1 or Cursor 2 sections of the Cursor Setup dialog box (when Horizontal Bars is selected in the Function section).

Group

Cursor

Related Commands

CURSor:FUNCtion

Syntax 1

CURSor:HBARS:POStion<x> <NR3>

Syntax 2

CURSor:HBARS:POStion<x>?

Argument

NR3

This argument specifies the cursor position relative to zero for the source waveform.

Example 1

CURSOR:HBARS:POStion1 3.0E-3

Positions Cursor 1 at 3 mV units above the zero level of the source waveform.

Example 2

```
CURSor:HBARs:POSition2?
```

This command might return `:CURSOR:HBARS:POSITION2 -1.96476964770E-003`, indicating that Cursor 2 is approximately 1.965 mV below the zero level of the source waveform.

CURSor:HBARs?

This query only command returns the current settings for the horizontal bar cursors.

Group

Cursor

Syntax

```
CURSor:HBARs?
```

Example

```
CURSor:HBARs?
```

This command might return

```
:CURSOR:HBARS:DELTA -4.01084010840E-003;  
POSITION1 2.01897018970E-003;  
POSITION2 -1.99186991870E-003.
```

CURSor:SELEct

This command sets or queries which cursor is active for front-panel control. The active cursor is displayed as a solid line and can be moved using the front-panel general-purpose knob. The unselected cursor is displayed as a dashed line. This command is equivalent to clicking in the Position control box in the Cursor 1 or Cursor 2 section of the Cursor Setup dialog box.

Group

Cursor

Syntax 1

```
CURSor:SELEct {CURSOR1|CURSOR2|NONE}
```

Syntax 2

```
CURSor:SELEct?
```

Arguments

- CURSOR1
Makes cursor 1 the active cursor.
- CURSOR2
Makes cursor 2 the active cursor.
- NONE

Disables cursor 1 and cursor 2 so that they cannot be moved by the front-panel general-purpose knob.

Example 1

```
CURSor:SElect CURSOR1
```

Sets cursor 1 as the active cursor, which is controllable by the front-panel general-purpose knob.

Example 2

```
CURSor:SElect?
```

This query might return `:CURSOR:SELECT CURSOR1`, indicating that cursor 1 is the active cursor and can be controlled by the front-panel general-purpose knob.

CURSor:VBArS?

This query only command returns the current settings of the vertical bar cursors.

Group

Cursor

Syntax

```
CURSor:VBArS?
```

Example

```
CURSOR:VBARS?
```

This query might return `:CURSOR:VBARS:DELTA`
`1.00601202405E-009;POSITION1 20.9968917836E-009;`
`POSITION2 22.0029038076E-009`

CURSor:VBArS:DELTA?

This query only command returns the difference between the two vertical bar cursors. This corresponds to the Δt value in the Cursors readout.

Group

Cursor

Syntax

```
CURSor:VBArS:DELTA?
```

Returns

NR3

Example

```
CURSOR:VBARS:DELTA?
```

This command might return `:CURSOR:VBARS:DELTA`
`1.65330661323E-009`, indicating the delta between the vertical bar cursors in absolute horizontal units.

CURSor:VBArS:POStion<x>

This command sets or queries the position of the specified vertical bar cursor, which is constrained to be within the displayed range. The cursor is specified by x, which can be 1 or 2. (Use the CURSor FUNction command to set the cursor function to vertical bars.) This is equivalent to entering a value in the Cursor 1 or Cursor 2 Position control in the Cursor Setup dialog box.

Group

Cursor

Related Commands

HORizontal:MAIn:TOFPoint?, HORizontal:MAG<x>:TOFPoint?,
HORizontal:MATH<x>:MAIn:TOFPoint?,,
HORizontal:MATH<x>MAG<x>:TOFPoint?,
HORizontal:REF<x>:MAIn:TOFPoint?,
HORizontal:REF<x>MAG<x>:TOFPoint?

Syntax 1

```
CURSor:VBArS:POStion<x> <NR3>
```

Syntax 2

```
CURSor:VBArS:POStion<x>?
```

Argument

NR3

This argument specifies the cursor position measured from the trigger point of the source waveform.

Example 1:

```
CURSor:VBArS:POStion2 9.0E-6
```

This command positions the cursor 2 vertical bar cursor at 9 μ s from the trigger point of the source waveform.

Example 2:

```
CURSor:VBArS:POStion1?
```

This query might return :CURSOR:VBARS:POSITION1

17.4929859719E-009, indicating that the cursor 1 vertical bar is at 17.49 ns from the trigger point of the source waveform.

CURSor:WAVeform:HDELTA?

This query-only command returns the horizontal difference between the waveform cursors. This is the absolute value of the horizontal position of the first cursor minus the horizontal position of the second cursor. This is equivalent to the waveform Δt readout value.

Group

Cursor

Syntax

```
CURSor:WAVeform:HDELTA?
```

Example

CURSor:WAVeform:HDELTA?

This query might return :CURSOR:WAVEFORM:HDELTA 1.03E-9, indicating that the time between the waveform cursors is 1.03 ns.

CURSor:WAVeform:HPOS<x>?

This query only command returns the position of the specified waveform cursor. The cursor is specified by x, which can be 1 or 2. This corresponds to the v1 or v2 (cursor 1 or cursor 2) cursor readout.

Group

Cursor

Syntax

CURSor:WAVeform:HPOS<x>?

Example

CURSor:WAVeform:HPOS1?

This query might return :CURSOR:WAVEFORM:HPOS2 0.247344970703, indicating that cursor 2 is at 247.3 mV with respect to ground on the source waveform.

CURSor:WAVeform:POSITION<x>

This command sets or queries the position of a waveform cursor, which is constrained to be visible in the selected timebase. (Use the CURSor FUNCtion command to set the cursor function to Waveform.) The cursor is specified by x, which can be 1 or 2. This is equivalent to setting a value in the Position control in the Cursor 1 or Cursor 2 sections of the Cursor Setup dialog box (when Waveform is selected in the Function section).

Group

Cursor

Related Commands

CURSor FUNCtion

Syntax 1

CURSor:WAVeform:POSITION<x> <NR3>

Syntax 2

CURSor:WAVeform:POSITION<x>?

Argument

NR3

This argument specifies the cursor position measured relative to the time of the trigger point of the source waveform.

Example 1

CURSor:WAVeform:POSITION2 9.00E-6

This command positions the cursor 2 waveform cursor at 9 μ s.

Example 2

CURSor:WAVeform:POSition2?

This query might return :CURSOR:WAVEFORM:POSITION2
51.0701402806E-009, indicating waveform cursor 1 is at 51.1 ns.

CURSor:WAVeform:VDELTA?

This query only command returns the vertical difference between the waveform cursors. This is the absolute value of the vertical position of the first cursor minus the vertical position of the second cursor. This is equivalent to the waveform Δv readout value.

Group

Cursor

Syntax

CURSor:WAVeform:VDELTA?

Example

CURSor:WAVeform:VDELTA?

This command might return CURSOR:WAVEFORM:VDELTA 1.06E-3, indicating that the voltage between the waveform cursors is 1.06 mV.

CURSor:WAVeform?

This query only command returns all of the waveform cursor parameters.

Group

Cursor

Syntax

CURSor:WAVeform?

Example

CURSor:WAVeform?

This query might return :CURSOR:WAVEFORM:HDELTA
0.487243652344;VDELTA -19.9398797595E-009;
HPOS1 0.241729736328;HPOS2 -0.245513916016;
POSITION1 31.1302605210E-009;
POSITION2 51.0701402806E-009

CURSor?

This is a query only command that returns all of the current cursor settings.

Group

Cursor

Syntax

CURSor?

Example: CURSOR?

This command might return the following as the current cursor settings:

```
:CURSOR:CURSOR1:COLOR 5;SOURCE CH3,MAIN;
:CURSOR:CURSOR2:COLOR 5;SOURCE CH3,MAIN;
:CURSOR:DIV2 0;FUNCTION WAVEFORMS;SELECT CURSOR1;
HBARS:DELTA -0.401084010840;POSITION1
0.201897018970;POSITION2 -0.199186991870;
:CURSOR:VBARS:DELTA 19.9398797595E-009;POSITION1
31.1302605210E-009;POSITION2 51.0701402806E-009;
:CURSOR:WAVEFORM:HDELTA 0.485961914062;VDELTA -
19.9398797595E-009;HPOS1 0.240936279297;HPOS2 -
0.245025634766;POSITION1 31.1302605210E-009;
POSITION2 51.0701402806E-009
```

CURVe

This query form of this command transfers waveform data from the instrument in binary or ASCII format. Use the DATA:SOURce and DATA:TIMEbase commands to specify the location (source) of the waveform data that is transferred from the instrument. Each waveform that is transferred has an associated waveform preamble that contains information such as data format and scale. Refer to the WFMOupre? query for information about the waveform preamble after the curve query command is completed. The data format is specified by the DATA:ENCdg command.

The first and last data points that are transferred are specified by the DATA:STARt and DATA:STOP commands.

The CURVe command transfers waveform data to the instrument. The data is stored in the reference memory location specified by DATA:DESTination, starting with the data point specified by the DATA:STARt command. Only one waveform can be transferred at a time. If the destination reference is not empty, the reference slot will be cleared, and the instrument will attempt to create a waveform using the provided data points. The waveform will only be displayed if the reference is displayed.

Group

Waveform Transfer

Related Commands

DATA:SOURce, DATA:TIMEbase, WFMOupre?, DATA:ENCdg, DATA:STARt, DATA:STOP, DATA:DESTination

Syntax 1

```
CURVe {<block>|<ascii>}
```

Syntax 2

```
CURVe?
```

Arguments

- block

This is the waveform data in binary format. The waveform is

formatted as: #<x><yyy><data><newline> where <x> is the number of y bytes. For example, if <yyy> = 500, then <x> = 3. <yyy> is the number of bytes to transfer including checksum.

- **ascii**

This is the waveform data in ASCII format. The format for ASCII data is <NR1>[,<NR1>...] where each <NR1> represents a data point.

Example

CURVe?

This command might return the following for ASCII data (partial):

```
:CURVE -509476864,-512163840,-511115264,-510918656,
-516161536,-484179968,-117112832,207093760,
322437120,351600640,409206784,468451328,
482934784,490668032,495517696,432668672,
482148352,483655680,493617152,495321088,
499843072,493420544,488964096,497221632,
503250944,501088256,501743616,503447552,
498139136,502857728,507248640,507117568,
503054336,506200064,505413632,502988800,
506658816,506920960,498008064,501415936,
504299520,498991104,496304128,499056640,
501612544,505806848,498794496,494206976,
414449664,-11141120,-274071552,-394330112,
-432865280,-450756608,-488439808,-500826112,...
```

DATa

This command sets or queries the format and location of the waveform data that is transferred with the CURVe command.

Group

Waveform Transfer

Related Commands

CURVe, WAVFrm?, DATa:STARt, DATa:STOP

Syntax 1

DATa {INIT|SNAP}

Syntax 2

DATa?

Arguments

- **INIT**

This argument initializes the waveform data parameters to their factory defaults.

- **SNAP**

This argument sets DATa:STARt and DATa:STOP to match the current vertical bar cursor positions.

Example 1

DATa SNAP

This command assigns the current position of the vertical bar cursors to DATA:START and DATA:STOP.

Example 2

DATA?

This query might return :DATA:DESTINATION REF1;SOURCE CH3;ENCDG ASCII;START 1;STOP 500.

DATA:DESTINATION

This command sets or queries the destination reference memory location for storing waveform data that is transferred into the instrument by the CURVe command.

Group

Waveform Transfer

Syntax 1

DATA:DESTINATION {REF<x>}

Syntax 2

DATA:DESTINATION?

Arguments

REF<x>

REF1 through REF8 are the reference memory locations where the waveform will be stored. You cannot have a channel as a destination.

Example 1

DATA:DESTINATION REF3

This command stores the incoming waveform data in Reference 3.

Example 2

DATA:DESTINATION?

This command might return :DATA:DESTINATION REF8 as the reference memory location that is currently selected.

DATA:ENCDg

This command sets or queries the format of the waveform data. This command is equivalent to setting WFMOutpre:ENCDg, WFMOutpre:BN_Fmt, and WFMOutpre:BYT_Or, as shown in the table below. Only signed, 4-byte integers and floating point values are supported. Changing the DATA:ENCDg parameter will coerce WFMOutpre formatter commands accordingly. If ASCII is selected, the output will be formatted to floating point or signed integer, based on how the data is stored in the instrument.

DATA and WFMOUtpre Parameter Settings			
DATA:ENCdg Setting	WFMOUtpre Settings		
	:ENCdg	:BN_Fmt	:BYT_Or
ASCIi	ASC	N/A	N/A
RIBinary	BIN	RI	MSB
FPBinary	BIN	FP	MSB
SRIbinary	BIN	RI	LSB
SFPBinary	BIN	FP	LSB

Group

Waveform Transfer

Related Commands

WFMOUtpre:ENCdg, WFMOUtpre:BN_Fmt, WFMOUtpre:BYT_Or

Syntax 1

DATA:ENCdg {ASCIi|RIBinary|FPBinary|SRIbinary|SFPBinary}

Syntax 2

DATA:ENCdg?

Arguments

- ASCIi**
 This argument specifies the ASCII representation of signed integer (RIBinary) data if the data source is a live channel; otherwise, if the data source is equal to the math then the ASCII curve data is in floating point format. If this is the value at power on, the WFMOUtpre values for BN_Fmt, BYT_Or, and ENCdg are set as RI, MSB, and ASCII respectively.
- RIBinary**
 This argument specifies signed integer data-point representation with the most-significant byte transferred first.
- FPBinary**
 This argument specifies floating-point data-point representation with the most-significant byte transferred first.
- SRIbinary**
 This is the same as RIBinary except that the byte order is reversed; the least-significant byte is transferred first. This format is useful when transferring data to IBM-compatible PCs.
- SFPBinary**
 This is the same as FPBinary except that the byte order is reversed; the least-significant byte is transferred first. This format is useful when transferring data to IBM-compatible PCs.

Example 1

DATA:ENCdg RIBinary

This command sets the data-encoding format to signed integer, with the most-significant byte transferred first.

Example 2

DATA:ENCdg?

This query might return DATA:ENCDG SFPBINARY, indicating that the format of the data is floating point, with the least-significant bit transferred first.

DATA:SOURce

This command sets or queries the location of the waveform data that is transferred from the instrument by the CURVe? query. Only one source can be set at a time. Changing the source waveform does not cause the WFMOutpre interpretation commands to update. To update these commands, you must send the CURVe? command. You may also set or query the timebase associated with the waveform data transferred from the instrument using the DATA:TIMEbase command.

Group

Waveform Transfer

Related Commands

DATA:TIMEbase

Syntax 1

DATA:SOURce {CH<x>|MATH<x>|REF<x>}

Syntax 2

DATA:SOURce?

Arguments

- CH<x>
This argument selects the specified channel (1 through 8) acquisition waveform as the waveform source.
- MATH<x>
This argument selects the specified Math (1 through 8) waveform as the waveform source.
- REF<x>
This argument selects the specified Reference (1 through 8) waveform as the waveform source.

Example 1

DATA:SOURce REF2

This command specifies that the Reference 2 waveform will be transferred in the next CURVe? query.

Example 2

DATA:SOURce?

This command might return `:DATA:SOURCE REF3`, indicating that Reference 3 waveform is the source for the waveform data that is transferred using a `CURVE?` query.

DATA:START

Sets or queries the starting data point for waveform transfer. This command allows for the transfer of partial waveforms to and from the instrument.

Group

Waveform Transfer

Related Commands

`CURVe?`, `DATA:STOP`

Syntax 1

`DATA:START <NR1>`

Syntax 2

`DATA:START?`

Argument

NR1

This value ranges from 1 to the record length and is the first data point that will be transferred. Data will be transferred from this point to `DATA:STOP` or the record length, whichever is less. If this value is greater than the record length, then no data will be transferred.

When `DATA:STOP` is less than `DATA:START`, the stop value will equal `DATA:START + (DATA:START - DATA:STOP)`. For example, if `DATA:START = 30` and `DATA:STOP = 20`, then the range of data points for the waveform transfer will equal 30 through 40.

Example 1

`DATA:START 10`

This command specifies that the waveform transfer will begin with data point 10.

Example 2

`DATA:START?`

This query might return `:DATA:START 214`, indicating that 214 is the first waveform data point that will be transferred.

DATA:STOP

Sets or queries the last data point that will be transferred when using the `CURVe?` query. This allows the transfer of partial waveforms to the controller.

When using the `CURVe` command, the instrument will stop reading data when there is no more data to read or when the specified record length is reached. When the specified record length is reached, this command will be ignored.

Group

Waveform Transfer

Related Commands

CURVe?, DATA:START

Syntax 1

DATA:STOP <NR1>

Syntax 2

DATA:STOP?

Argument

NR1

This value ranges from 1 to the record length and is the last data point that will be transferred. If this value is greater than the record length, then data will be transferred up to the record length. If both DATA:START and DATA:STOP are greater than the record length, an execution error will be generated.

If you always want to transfer complete waveforms, just set DATA:START to 1 and DATA:STOP to the maximum record length.

When DATA:STOP is less than DATA:START, the stop value will equal DATA:START + (DATA:START - DATA:STOP). For example, if DATA:START = 30 and DATA:STOP = 20, then the range of data points for the waveform transfer will equal 30 through 40.

Example 1

DATA:STOP 4000

This command specifies that the waveform transfer will stop at data point 4000.

Example 2

DATA:STOP?

This query might return :DATA:STOP 500, indicating that 500 is the last data point that will be transferred.

DATA:TIMEbase

Sets or queries the DATA:SOURce associated timebase used to specify the location of the waveform data to be transferred from the instrument when using the CURVe? command. The specified timebase must be active and displayed in order to receive data.

Group

Waveform Transfer

Related Commands

CURVe?, DATA:SOURce

Syntax 1

DATA:TIMEbase {MAIn|MAG1|MAG2}

Syntax 2

DATA:TIMEbase?

Arguments

MAIn: This argument selects MAIn as the timebase for the waveform data to be transferred out by the next CURVe? command.

MAG1: This argument selects MAG1 as the timebase for the waveform data to be transferred out by the next CURVe? Command.

MAG2: This argument selects MAG2 as the timebase for the waveform data to be transferred out by the next CURVe? command.

Example

DATA:TIMEbase MAG1

This command sets the timebase for the waveform data to be transferred out to MAG1.

DATA:TIMEbase?

This command might return :DATA:TIMEbase MAIN, indicating that the timebase for the source waveform data is set to main.

DATE

This command sets or queries the date that the instrument can display.

Group

Miscellaneous

Related Commands

TIME

Syntax 1

DATE <QString>

Syntax 2

DATE?

Arguments

<QString>

This is a date in the form "yyyy-mm-dd".

- *YYYY*
This is a four-digit year number.
- *mm*
This is a two-digit month number from 01 to 12.
- *dd*
This is a two-digit day number in the month.

Note: There must a dash (-) after the yyyy and after the mm.

Example 1

DATE "2000-01-24"

This command sets the date to January 24, 2000.

Example 2

DATE?

This query might return :DATE 1999-06-01, indicating that the date is June 1, 1999.

DELEte:WAVEform

This command (no query form) deletes one or all of the stored reference waveforms from memory. The memory allocated for the reference location is then available for reallocation.

Note: A reference waveform cannot be deleted if it is a source client for some other operation, such as a histogram source, math source, measurement, or waveform database.

Group

Save and Recall

Related Commands

RECALL:WAVEform, SAVe:WAVEform

Syntax

```
DELEte:WAVEform {REF<x>|ALL}
```

Arguments

- REF<x>
Specifies one of the reference memory locations (REF1 through REF8).
- ALL
Specifies all the stored reference waveforms.

Example 1

```
DELEte:WAVEform ALL
```

Removes all the waveforms stored in reference memory.

Example 2

```
DELEte:WAVEform REF2
```

Removes the waveform stored at REF2.

DESE

This command sets or queries the bits in the Device Event Status Enable Register (DESER). The DESER is the mask that determines whether events are reported to the Standard Event Status Register (SESR) and entered into the Event Queue. For a more detailed discussion of the use of these registers, see *Registers* on page 337.

Group

Status and Error

Related Commands

*CLS, *ESE, *ESR?, EVENT?, EVMsg?, *SRE, *STB?

Syntax 1

DESE <NR1>

Syntax 2

DESE?

Argument

<NR1>

This is a value in the range from 0 through 255. The binary bits of the DESER are set according to this value. For example, DESE 209 sets the DESER to the binary value 11010001 (that is, the most significant bit in the register is set to 1, the next most significant bit to 1, the next bit to 0, and so on).

The power-on default for DESER is all bits set if *PSC is 1. If *PSC is 0, the DESER maintains its value through a power cycle.

*Note: Setting the DESER and the ESER to the same value allows only those codes to be entered into the Event Queue and summarized on the ESB bit (bit 5) of the Status Byte Register. Use the *ESE command to set the ESER.*

Example 1

DESE 209

Sets the DESER to binary 11010001, which enables the PON, URQ, EXE, and OPC bits.

Example 2

DESE?

This query might return :DESE 186, indicating that the DESER contains the binary value 10111010.

DISplay:COLor:BACKground

This command sets or queries the color of the graticule background. This is equivalent to setting the Background color in the Graticule section of the Display Setup dialog box. The default background color is black. The available background colors are listed in the following table.

Available Background Colors		
Example	Name	Index Number
	Black	0
	Blue	1
	Aqua	2
	Lime	3
	Fuchsia	4
	Red	5
	Yellow	6
	White	7
	Navy	8
	Teal	9
	Green	10
	Purple	11
	Maroon	12
	Olive	13
	Gray	14
	Silver	15

Group

DISplay Control

Syntax 1

DISplay:COLor:BACKground <NR1>

Syntax 2

DISplay:COLor:BACKground?

Argument

NR1

NR1 is an integer in the range from 0 through 15 representing a color as defined in the above table.

Example 1

DISplay:COLor:BACKground 2

This command sets the color of the graticule background to aqua.

Example 2

DISplay:COLor:BACKground?

This query might return DISPLAY:COLOR:BACKGROUND 7, indicating that the color of the graticule background is white.

DISplay:COLor:CURSOR<x>

This command sets or queries the color of the specified cursor (x), which may be 1 or 2. This is equivalent to setting Color in the Cursor 1 or

Cursor 2 section of the Cursor Setup dialog box. The available colors are listed in the following table.

Available Cursor Colors		
Example	Name	Index Number
	Black	0
	Blue	1
	Aqua	2
	Lime	3
	Fuchsia	4
	Red	5
	Yellow	6
	White	7
	Navy	8
	Teal	9
	Green	10
	Purple	11
	Maroon	12
	Olive	13
	Gray	14
	Silver	15

Group

Display Control

Related Commands

CURSor:CURSor<x>:COLOr

Syntax 1

DISplay:COLor:CURSOR<x> <NR1>

Syntax 2

DISplay:COLor:CURSOR<x>?

Argument

NR1

NR1 is an integer in the range of 0 through 15 representing a color as defined in the above table.

Example 1

DISplay:COLor:CURSOR1 6

This command sets the color of Cursor 1 to yellow.

Example 2

DISplay:COLor:CURSOR2?

This query might return :DISPLAY:COLOR:CURSOR2 9, indicating that the color of Cursor 2 is Teal.

DISplay:COLor:FOREground

This command sets or queries the color of the graticule foreground, which is the color of the graticule itself. This is equivalent to setting the Foreground color in the Graticule section of the Display Setup dialog box. The default foreground color is silver. The available foreground colors are listed in the following table.

Available Foreground Colors		
Example	Name	Index Number
	Black	0
	Blue	1
	Aqua	2
	Lime	3
	Fuchsia	4
	Red	5
	Yellow	6
	White	7
	Navy	8
	Teal	9
	Green	10
	Purple	11
	Maroon	12
	Olive	13
	Gray	14
	Silver	15

Group

Display Control

Syntax 1

```
DISplay:COLor:FOREground <NR1>
```

Syntax 2

```
DISplay:COLor:FOREground?
```

Argument

NR1

NR1 is an integer in the range of 0 through 15 representing a color as defined in the above table.

Example 1

```
DISplay:COLor:FOREground 5
```

This command sets the color of the foreground (graticule) to red.

Example 2

```
DISplay:COLor:FOREground?
```

This query might return `:DISPLAY:COLOR:FOREGROUND 7`, indicating that the color of the foreground (graticule) is white.

DISplay:COLor:HIStogram

This command sets or queries the color of the histogram data and its boundary area. (This command is the same as the HISTogram:COLOR command.) This is equivalent to setting Color in the Display Options section of the Histogram Setup dialog box. The available colors are listed in the following table.

Available Histogram Colors		
Example	Name	Index Number
	Black	0
	Blue	1
	Aqua	2
	Lime	3
	Fuchsia	4
	Red	5
	Yellow	6
	White	7
	Navy	8
	Teal	9
	Green	10
	Purple	11
	Maroon	12
	Olive	13
	Gray	14
	Silver	15

Group

Display Control

Related Commands

HISTogram:COLOR

Syntax 1

DISplay:COLor:HIStogram <NR1>

Syntax 2

DISplay:COLor:HIStogram?

Argument

NR1

NR1 is an integer in the range of 0 through 15 representing a color as defined in the above table.

Example 1

DISplay:COLor:HISTogram 12

This command sets the color of the histogram data and its boundary area to maroon.

Example 2

DISplay:COLor:HISTogram?

This query might return :DISPLAY:COLOR:HISTOGRAM 14, indicating that the color of the histogram data and its boundary is gray.

DISplay:COLor:MASK

This command sets or queries the color of the mask. (The command is the same as the MASK:COLOr command. This is equivalent to setting Color in the Options section of the Mask Setup dialog box. The available colors are listed in the following table.

Available Mask Colors		
Example	Name	Index Number
	Black	0
	Blue	1
	Aqua	2
	Lime	3
	Fuchsia	4
	Red	5
	Yellow	6
	White	7
	Navy	8
	Teal	9
	Green	10
	Purple	11
	Maroon	12
	Olive	13
	Gray	14
	Silver	15

Group

Display Control

Related Commands

MASK:COLOr

Syntax 1

DISplay:COLor:MASK <NR1>

Syntax 2

DISplay:COLor:MASK?

Argument

NR1

NR1 is an integer in the range of 0 through 15 representing a color as defined in the above table.

Example 1

```
DISplay:COLor:MASK 4
```

This command sets the color of the mask to fuchsia.

Example 2

```
DISplay:COLor:MASK?
```

This query might return `:DISPLAY:COLOR:MASK 10`, indicating that the color of the mask is green.

DISplay:COLor?

This query only command returns the colors used in the display. These include colors assigned to the following:

- Graticule background
- Graticule foreground
- Histogram
- Mask
- Cursor 1
- Cursor 2

The possible colors are listed in the following table.

Available Colors		
Example	Name	Index Number
	Black	0
	Blue	1
	Aqua	2
	Lime	3
	Fuchsia	4
	Red	5
	Yellow	6
	White	7
	Navy	8
	Teal	9
	Green	10
	Purple	11
	Maroon	12
	Olive	13
	Gray	14
	Silver	15

Group

Display Control

Syntax

DISplay:COLor?

Example

DISplay:COLor?

This query might return :DISPLAY:COLOR:BACKGROUND 0;FOREGROUND 15;CURSOR1 5;CURSOR2 5;HISTOGRAM 2;MASK 4.

DISplay:CURSReadout

This command sets or queries state of the Cursors readout. This is equivalent to toggling the Cursor readout off or on with the Cursor readout icon in the toolbar.

Group

Display Control

Syntax 1

DISplay:CURSReadout {ON|OFF|NR1}

Syntax 2

DISplay:CURSReadout?

Arguments

- ON
Enables the readout display for the Cursor function.
- OFF
Disables the readout display for the Cursor function.
- NR1
A 0 disables the Cursor readout display; any other integer enables the Cursor readout display.

Example 1

```
DISplay:CURSReadout 1
```

This command enables the Cursor readout display.

Example 2

```
DISplay:CURSReadout?
```

This query might return `:DISPLAY:CURSREADOUT 0`, indicating that the Cursor readout display is off.

NOTE: A query always returns a 0 or 1.

DISplay:GRAticule:HDIVS?

This query only command returns the number of horizontal divisions in the graticule.

Group

Display Control

Syntax

```
DISplay:GRAticule:HDIVS?
```

Example

```
DISplay:GRAticule:HDIVS?
```

This query might return `:DISPLAY:GRATICULE:HDIVS 10`, indicating that the graticule display is 10 horizontal divisions wide.

DISplay:GRAticule:STYLE

This command selects the style of graticule that is displayed. Sending the command is equivalent to setting Style in the Graticule section of the Display Setup dialog box. The following are the available graticule styles:

- Full (default)
- Crosshair
- Grid
- Frame

Group

Display Control

Syntax 1

```
DISplay:GRAticule:STYLE {FULl|CROSSHair|GRId|FRame}
```

Syntax 2

```
DISplay:GRAticule:STYLE?
```

Arguments

- `FULl`
Specifies a frame, a grid, and cross hairs.
- `CROSSHair`
Specifies a frame and cross hairs.
- `GRId`
Specifies a frame and a grid.
- `FRame`
Specifies just a frame.

Example 1

```
DISpLAY:GRATICULE:STYLE GRID
```

Sets the graticule style to display a frame and a grid.

Example 2

```
DISpLAY:GRATICULE:STYLE?
```

This query might return `:DISPLAY:GRATICULE:STYLE FULL` when all graticule elements (grid, frame, and cross hairs) are displayed.

DISplay:GRAticule:VDIVS?

This query only command returns the number of vertical divisions in the graticule.

Group

Display Control

Syntax

```
DISplay:GRAticule:VDIVS?
```

Example

```
DISplay:GRAticule:VDIVS?
```

This query might return `:DISPLAY:GRATICULE:VDIVS 10`, indicating that the graticule display is 10 vertical divisions high.

DISplay:GRAticule?

This query only command returns all the graticule parameters.

Group

Display Control

Syntax

DISplay:GRAticule?

Example

DISplay:GRAticule?

This query might return :DISPLAY:GRATICULE:STYLE FULL;
HDIVS 0.100000000000;VDIVS 0.100000000000.

DISplay:HISTReadout

This command sets or queries state of the Histogram readout. This is equivalent to toggling the Histogram readout off or on with the Histogram readout icon in the toolbar.

Group

Display Control

Syntax 1

DISplay:HISTReadout {ON|OFF|NR1}

Syntax 2

DISplay:HISTReadout?

Arguments

- ON
Enables the readout display for the Histogram function.
- OFF
Disables the readout display for the Histogram function.
- NR1
A 0 disables the Histogram readout display; any other integer enables the Histogram readout display.

Example 1

DISplay:HISTReadout 1

This command enables the Histogram readout display.

Example 2

DISplay:HISTReadout?

This query might return :DISPLAY:HISTREADOUT 0, indicating that the Histogram readout display is off.

NOTE: A query always returns a 0 or 1.

DISplay:INTERPolat

This command sets or queries the interpolation algorithm used to display any waveforms in the Main or Mag views when the record length is less than 500 points. This is equivalent to setting Interpolation in the Style section of the Display Setup dialog box.

Note: Interpolation is a display function only; the instrument does not do acquisition interpolation.

With interpolation and for high acquisition rates, the instrument increases the sample density on the waveforms it displays by calculating intermediate points for those sampled. You can set one of the following Interpolation display algorithms:

- None (default). Turns interpolation off.
- Sin (X)/X. This algorithm computes points using a curve fit between the actual values acquired. It assumes all interpolated points fall along the curve. This is useful when displaying more rounded waveforms such as sine waves. This algorithm can be used for general use, but it may introduce some overshoot or undershoot in signals with fast rise times.
- Linear. This algorithm computes points between actual acquired samples by using a straight line fit. The algorithm assumes all interpolated points fall along the straight line. Linear interpolation is useful for many waveforms such as pulse trains.

Group

Display Control

Related Commands

DISplay:STYLE

Syntax 1

```
DISplay:INTERPolat {LINear|NONE|SINX}
```

Syntax 2

```
DISplay:INTERPolat?
```

Arguments

- LINear
Specifies linear interpolation.
- NONe
Turns off the interpolation function.
- SINX
Specifies Sin (x)/x interpolation.

Example 1

```
DISplay:INTERPolat LINear
```

This command selects the linear interpolation algorithm.

Example 2

```
DISplay:INTERPolat?
```

This query might return :DISPLAY:INTERPOLAT NONE, indicating that no interpolation algorithm is selected.

DISplay:MASKReadout

This command sets or queries state of the Mask readout. This is equivalent to toggling the Mask readout off or on with the Mask readout icon in the toolbar.

Group

Display Control

Syntax 1

```
DISplay:MASKReadout {ON|OFF|NR1}
```

Syntax 2

```
DISplay:MASKReadout?
```

Arguments

- ON
Enables the readout display for the Mask function.
- OFF
Disables the readout display for the Mask function.
- NR1
A 0 disables the Mask readout display; any other integer enables the Mask readout display.

Example 1

```
DISplay:MASKReadout 1
```

This command enables the Mask readout display.

Example 2

```
DISplay:MASKReadout?
```

This query might return `:DISPLAY:MASKREADOUT 0`, indicating that the Mask readout display is off.

NOTE: A query always returns a 0 or 1.

DISplay:MEASBar

This command sets or queries whether or not the Measurement Bar is displayed. This is equivalent to checking or clearing the Measurement Bar menu item in the View menu.

Group

Display Control

Syntax 1

```
DISplay:MEASBar {ON|OFF|NR1}
```

Syntax 2

```
DISplay:MEASBar?
```

Arguments

- ON

Enables the Measurement Bar display.

- OFF

Disables the Measurement Bar display.

- NR1

A 0 disables the Measurement Bar display; any other integer enables the Measurement Bar display.

Example 1

```
DISplay:MEASBar 1
```

This command enables the Measurement Bar display.

Example 2

```
DISplay:MEASBar?
```

This query might return :DISPLAY:MEASBAR 0, indicating that the Measurement Bar display is off.

NOTE: A query always returns a 0 or 1.

DISplay:MEASReadout

This command sets or queries state of the measurement readout. This is equivalent to toggling the Measurement readout off or on with the Measurement readout icon in the toolbar.

Group

Display Control

Syntax 1

```
DISplay:MEASReadout {ON|OFF|NR1}
```

Syntax 2

```
DISplay:MEASReadout?
```

Arguments

- ON

Enables the readout display for the Measurement function.

- OFF

Disables the readout display for the Measurement function.

- NR1

A 0 disables the Measurement readout display; any other integer enables the Measurement readout display.

Example 1

```
DISplay:MEASReadout 1
```

This command enables the Measurement readout display.

Example 2

```
DISplay:MEASReadout?
```

This query might return `:DISPLAY:MEASREADOUT 0`, indicating that the Measurement readout display is off.

NOTE: A query always returns a 0 or 1.

DISplay:PERsistence

This command sets or queries the length of time that data points are displayed when variable persistence is active. This affects the display only and is equivalent to setting Time in the Style section of the Display Setup dialog box.

Group

DISplay Control

Related Commands

DISplay:STYle

Syntax 1

DISplay:PERsistence <NR3>

Syntax 2

DISplay:PERsistence?

Argument

NR3

Specifies the length, in seconds, that the waveform points are displayed on the screen. The range is 500 ms to 100 s (in increments of 100 ms from 500 ms to 1s and in 0.5 s increments from 1 s to 100 s).

Example 1

DISplay:PERsistence 3

Specifies that the waveform points are displayed on the screen for 3 seconds before they fade.

Example 2

DISplay:PERsistence?

This query might return `:DISPLAY:PERSISTENCE 0.200000000000` indicating that the persistence is set to 200 ms.

DISplay:SHOWVector

This command sets or queries the Show Vectors mode. For the Normal display style only, you can set the instrument to draw vectors between displayed waveform points. This is equivalent to selecting or clearing the Show Vectors check box in the Style section of the Display Setup dialog box.

Group

Display Control

Related Commands

DISplay:STYle

Syntax 1

```
DISplay:SHOWVector {ON|OFF|NR1}
```

Syntax 2

```
DISplay:SHOWVector?
```

Arguments

- ON
Enables the vector display.
- OFF
Disables the vector display.
- NR1
0 disables the vector display; any other integer enables the vector display.

Example 1

```
DISplay:SHOWVector ON
```

This enables the Show Vectors mode, which displays lines between the sampled (or interpolated) points.

Example 2

```
DISplay:SHOWVector?
```

This query might return `:DISPLAY:SHOWVECTOR 0`, indicating that the vector display is disabled, and the waveform is displayed as dots.

NOTE: A query always returns a 0 or 1.

DISplay:STYLE

This command sets or queries whether or not the data is displayed using persistence. Sending this command is equivalent to selecting Variable Persistence or Infinite Persistence (or neither) in the Style section of the Display Setup dialog box.

Group

Display Control

Related Commands

```
DISplay:PERSistence
```

Syntax 1

```
DISplay:STYLE {NORMal|INFPersist|VARPersist}
```

Syntax 2

```
DISplay:STYLE?
```

Arguments

- NORMal
Disables the persistence mode.
- INFPersist

Accumulates data points on the display indefinitely. The display is reset when the style or acquisition is reset.

- `VARPersist`

Leaves acquired data points on the display for a period of time specified by the `DISplay:PERSistence` command.

Example 1

```
DISplay:STYLE INFPersist
```

Sets the display to indefinitely accumulate data points on the screen.

Example 2

```
DISplay:STYLE?
```

This command might return `:DISPLAY:STYLE VARPERSIST`, indicating that the display style is set to variable persistence.

DISpLay:WFMReadout

This command sets or queries state of the Waveform readout. This is equivalent to toggling the Waveform readout off or on with the Waveform readout icon in the toolbar.

Group

Display Control

Syntax 1

```
DISplay:WFMReadout {ON|OFF|NR1}
```

Syntax 2

```
DISplay:WFMReadout?
```

Arguments

- `ON`
Enables the readout display for the Waveform function.
- `OFF`
Disables the readout display for the Waveform function.
- `NR1`
A 0 disables the Waveform readout display; any other integer enables the Waveform readout display.

Example 1

```
DISplay:WFMReadout 1
```

This command enables the Waveform readout display.

Example 2

```
DISplay:WFMReadout?
```

This query might return `:DISPLAY:WFMREADOUT 0`, indicating that the Waveform readout display is off.

NOTE: A query always returns a 0 or 1.

DISplay?

This is a query only command that returns the current display settings.

Group

Display Control

Syntax

DISplay?

Example

DISplay?

This command might return the following:

```
:DISPLAY:PERSISTENCE 0.200000000000;STYLE
NORMAL;INTERPOLAT SINX;SHOWVECTOR 1;GRATICULE:STYLE
FULL;HDIVS 1.000000000000;VDIVS
1.000000000000;:DISPLAY:COLOR:BACKGROUND 0;FOREGROUND
7;CURSOR1 5;CURSOR2 5;HISTOGRAM 2;MASK
4;:DISPLAY:MEASREADOUT 0;CURSREADOUT 0;HISTREADOUT
0;WFMREADOUT 1;MASKREADOUT 0;MEASBAR 1
```

EVENT?

This is a query only command that returns an event code from the Event Queue that provides information about the results of the last *ESR? read. EVENT? also removes the returned value from the Event Queue. For more information, see *Event Handling Sequence* on page 341.

Group

Status and Error

Related Commands

ALLev?, *CLS, DESE, *ESE, *ESR?, EVMsg?, *SRE, *STB?

Syntax

EVENT?

Example

EVENT?

This query might return the response :EVENT 110, indicating that there was an error in a command header.

EVMsg?

This is a query only command that removes a single event code from the Event Queue that is associated with the results of the last *ESR? read and returns the event code along with an explanatory message. For more information, see *Event Handling Sequence* on page 341.

Group

Status and Error

Related Commands

ALLev?, *CLS, DESE, *ESE, *ESR?, EVENT?, *SRE, *STB

Syntax

EVMsg?

Returns

The event code and message in the following format:

```
<Event Code><Comma><QString>[<Event Code><Comma>
<QString>...]<QString>::= <Message>;[<Command>]
```

where <Command> is the command that caused the error and may be returned when a command error is detected by the instrument. As much of the command will be returned as possible without exceeding the 60-character limit of the <Message> and <Command> strings combined. The command string is right justified.

Example

EVMSG?

This query might return :EVMSG 110, "Command header error".

EVQty?

This query only command returns the number of event codes that are in the Event Queue. This is useful when using the ALLEv? query, since it lets you know exactly how many events will be returned.

Group

Status and Error

Related Commands

ALLEv?, EVENT?, EVMsg?

Syntax

EVQty?

Example

EVQTY?

This query might return :EVQTY 3, indicating that there are three event codes in the Event Queue.

EXPort

This command (no query form) exports waveform data to a file as a series of comma-separated values (CSV) in ASCII text. Exporting data in this format allows you to use it with other analysis tools, such as spreadsheets or math analysis applications. Exported waveforms cannot be imported. If you intend to recall a waveform later, you should save it instead of exporting it.

Group

Save and Recall

Related Commands

Syntax

```
EXPort {CH<x>|MATH<x>|REF<x>|HIST}[ ,  
{MAIn|MAG1|MAG2}]], <filepath>
```

Arguments

- CH<x>
This argument selects a channel waveform to export. The range for x is 1 through 8.
- MATH<x>
This argument selects a math waveform to export. The range for x is 1 through 8.
- REF<x>
This argument selects a reference waveform to export. The range for x is 1 through 8.
- HIST
This argument selects histogram data to export.
- MAIn
This optional argument selects Main as the timebase for the exported waveform. This is the default timebase.
- MAG1
This optional argument selects MAG1 as the timebase for the exported waveform.
- MAG2
This optional argument selects MAG2 as the timebase for the exported waveform.
- <file path>
This is the location to which the waveform will be exported.

The <file path> is a quoted string that defines the file name and path. Input the file path using the form <drive>/<dir>/<filename>. The <filename> can be a Windows 95/Windows 98 long file name. Do not use wild card characters.

Example

```
EXPort REF2 "C:\My Documents\TDS8000\MainR2.txt"
```

FACTory

This command (no query form) resets the instrument to its factory default settings. Sending this command is equivalent to pressing the front-panel DEFAULT SETUP button or selecting Default Setup in the Utilities menu.

Executing the FACTory command does the following actions:

- Clears the Event Status Enable Register
- Clears the Service Request Enable Register
- Sets the Device Event Status Enable Register to 255
- Sets the Power On Status Clear Flag to TRUE
- Enables all Command Headers (HEADer ON)
- Clears the pending operation flag and associated operations
- Clears all references from the reference slots
- The FACtory command does not change the following:
 - The state of the GPIB (IEEE Std 488.1-1987) interface
 - The selected GPIB address
 - Data transfer settings
 - Calibration data that affects device specifications
 - Protected user data
 - Stored settings

Group

Miscellaneous

Related Commands

RECALL:SETUp, *RST, SAVe:SETUp

Syntax

FACTory

Example

FACTory

FILESystem:READFile? <file path>

Outputs the specified file to the GPIB port with maximum file size of 10Mb

Argument

- `file path`
 <file path> is a quoted string that defines the file name and path. Input the file path using the form "<drive>\dir\filename". The <filename> can be a Windows95/Windows 98 long file name. Do not use wild card characters.

Example

FILESYSTEM:READFILE? "c:\My Documents\Pi\test.txt"

HARDCopy

This command (no query form) sends a copy of the screen display followed by an EOI to the hard copy port. Sending this command is equivalent to pressing the front-panel PRINT button.

Note: This command is NOT IEEE STD 488.2-1987 compatible.

Group

Hardcopy

Related Commands

HARDCopy:FORMat

HARDCopy:FILEName

HARDCopy:INKSaver

Syntax

HARDCopy {START}

Arguments

START

Initiates a screen copy that is sent to the controller where it is redirected to a printing device.

*Note: Use the *WAI command between HARDCopy START commands to ensure that the first hardcopy task is sent to the printer before starting another.*

Example

```
HARDCOPY START
```

Starts a hardcopy.

HARDCopy:FILEName

This command immediately sends a copy of the screen display to the file specified by the command argument. The filename may include a relative path, or a fully qualified path, to any location supported by Microsoft Windows, including the local hard disk, floppy drive, and network folders.

Note. If the file you specify doesn't exist, sending this command creates it. If the file does exist, sending this command overwrites its contents.

The image-file format that your hardcopy will have depends on whether you include a file extension when you specify the file path:

- If your :FILEName argument does not include a file extension, the file extension associated with the format set by the HARDCopy:FORMat command is automatically appended and that image-file format is used. You can change the file format using the HARDCopy:FORMat command, sending it before you send the HARDCopy:FILEName command.
- If your :FILEName argument does include a file extension, the image-file associated with it is used instead. The file extension must

be one associated with one of the formats listed for the HARDCopy:FORMAt command.

Group

Hardcopy

Related Commands

HARDCopy

HARDCopy:FORMAt

HARDCopy:INKSaver

Syntax

```
HARDCopy:FILENAME <file path>
```

Argument

file path

This argument specifies the file to which the hardcopy is sent. This argument is a quoted string that defines the file name, path, and, optionally, the file format if you include a file extension (see the description above).

Note. The specified filename must be enclosed with quotation marks and wild card characters are illegal.

Example 1

```
HARDCOPY:FILENAME "C:\My Documents\tek"
```

Immediately outputs a hardcopy to the file TEK.<format>, where <format> is the image-file format set by the HARDCopy:FORMAt command, or by the optional file-name extension (see the description above).

Example 2

```
HARDCOPY:FILENAME "C:\My Documents\tek.png"
```

Immediately outputs a hardcopy to the file TEK.PNG, where PNG is image-file format set by the file-name extension included in the command argument (see the description above).

HARDCopy:FORMAt

This command selects the image-file format used with the hardcopy commands. Several image file formats are provided to support compatibility with image-processing applications and efficient utilization of disk capacity.

Syntax

```
HARDCopy:FORMAt {PNG|JPEG|BMP|TIFF|TARGA}
```

Arguments

- PNG
Sets the hardcopy format to PNG. This setting produces compressed image files between 20KB and 100KB. This format uses a lossless image compression algorithm and will always produce the smallest file size of the available formats.

- **JPEG**
Sets the hardcopy format to JPEG. This setting produces compressed image files between 60KB and 100KB. This format uses a lossy image compression algorithm.
- **BMP**
Sets the hardcopy format to BMP. This setting produces minimally compressed (RLE) image files around 1MB. This is the default image file format and is commonly supported by Microsoft Windows compatible applications.
- **TIFF**
Sets the hardcopy format to TIFF. This setting produces uncompressed image files that are typically larger than 1MB.
- **TARGA**
Sets the hardcopy format to TARGA. This setting produces minimally compressed (RLE) image files around 1MB.

Related Commands

HARDCopy:FILENAME
HARDCopy

Example

HARDCOPY:FORMAT PNG

Selects PNG as the file format to which hardcopy data is sent.

HARDCopy:INKSAVER

This command turns Ink-saver mode on and off. When Ink-saver mode is on, hardcopies are produced with a white background to conserve ink. Ink-saver mode can be used when sending hardcopy images to a printer, or when sending hardcopy images to a file using the HARDCopy:FILENAME command.

Group

Hardcopy

Related Commands

HARDCopy
HARDCopy:FORMAT
HARDCopy:FILENAME

Syntax

HARDCopy:INKSAVER {ON | OFF | 0 | 1}

Argument

{ON | OFF | 0 | 1}

This argument turns Ink-saver mode on and off

Example 1

HARDCOPY:INKSAVER ON

Turns Ink-saver mode on for subsequent hardcopy commands.

Example 2

HARDCOPY:INKSAVER?

This query will return : HARDCOPY:INKSAVER 1 if Ink-saver mode is currently on.

HEADer

This command sets and queries the Response Header Enable State that causes the instrument to either include or omit headers on query responses. This command does not affect IEEE Std 488.2-1987 Common Commands (those starting with an asterisk); these commands never return headers.

Group

Miscellaneous

Related Commands

VERBose

Syntax 1

HEADer {ON|OFF|NR1}

Syntax 2

HEADer?

Arguments

- ON
Sets the Response Header Enable State to true. This causes the instrument to include headers on applicable query responses. You can then use the query response as a command.
- OFF
Sets the Response Header Enable State to false. This causes the instrument to omit headers on query responses so that only the argument is returned.
- NR1
0 sets the Response Header Enable State to false, which disables the headers; any other integer sets the Response Header Enable State to true, which enables the headers. (A query always returns a 0 or 1.)

Example 1

HEADER OFF

This command causes the instrument to omit headers from query responses.

Example 2

HEADER?

This query might return :HEADER 1, indicating that the Response Header Enable State is on.

NOTE: A query always returns a 0 or 1.

HISTogram:BOX

Defines the left, top, right, and bottom boundaries of the histogram box in source waveform coordinates. This is equivalent to setting the Limit Controls for Left, Top, Right, and Bottom in the Histogram Setup dialog box. This command is similar to the HISTogram:BOXPcnt command, which uses percentage coordinates to define the boundaries of the histogram box.

Group

Histogram

Related Commands

HISTogram:BOXPcnt

Syntax 1

```
HISTogram:BOX <NR3> , <NR3> , <NR3> , <NR3>
```

Syntax 2

```
HISTogram:BOX?
```

Arguments

- NR3
The left position of the histogram box in source waveform coordinates.
- NR3
The top position of the histogram box in source waveform coordinates.
- NR3
The right position of the histogram box in source waveform coordinates.
- NR3
The bottom position of the histogram box in source waveform coordinates.

Example 1

```
HISTOGRAM:BOX 1.518E-006 , -2.46E-1 , 3.518E-6 ,  
-7.47E-1
```

This command defines the coordinates of the histogram box in source waveform coordinates.

Example 2

```
HISTOGRAM:BOX?
```

This query might return :HISTOGRAM:BOX 1.518000000000E-006 , -0.246000000000 , 3.518000000000E-006 , -0.747000000000.

HISistogram:BOXPcnt

Defines the left, top, right, and bottom positions of the histogram box, in percentage of screen coordinates. The upper left has the value 0, 0 and the lower right has the value 100, 100. Any value outside the range of 0 to 100 is clipped and generates an error. This command is similar to the HISistogram:BOX command, which uses waveform coordinates to define the boundaries of the histogram box.

Group

Histogram

Related Commands

HISistogram:BOX

Syntax 1

```
HISistogram:BOXPcnt <NR3> , <NR3> , <NR3> , <NR3>
```

Syntax 2

```
HISistogram:BOXPcnt?
```

Arguments

- NR3
The left position of the histogram box in percentage coordinates. The default value is 30.
- NR3
The top position of the histogram box in percentage coordinates. The default value is 25.
- NR3
The right position of the histogram box in percentage coordinates. The default value is 70.
- NR3
The bottom position of the histogram box in percentage coordinates. The default value is 75.

Example 1

```
HISistogram:BOXPcnt 35,21,72,76
```

This command defines the coordinates of a histogram box in percentage coordinates.

Example 2

```
HISistogram:BOXPcnt?
```

This query might return

```
:HISTOGRAM:BOXPCNT 30.0000000000,  
25.0000000000,70.0000000000,  
75.0000000000.
```

HISTogram:COLOR

This command sets or queries the color of the histogram data and its boundary area. (This command is the same as the DISplay:COLor:HISTogram command.) This is equivalent to setting Color in the Display Options section of the Histogram Setup dialog box. The available colors are listed in the following table.

Available Histogram Colors		
Example	Name	Index Number
	Black	0
	Blue	1
	Aqua	2
	Lime	3
	Fuchsia	4
	Red	5
	Yellow	6
	White	7
	Navy	8
	Teal	9
	Green	10
	Purple	11
	Maroon	12
	Olive	13
	Gray	14
	Silver	15

Group

Histogram

Related Commands

DISplay:COLor:HISTogram

Syntax 1

HISTogram:COLOR <NR1>

Syntax 2

HISTogram:COLOR?

Argument

NR1

NR1 is an integer in the range of 0 through 15 representing a color as defined in the above table.

Example 1

HISTogram:COLOR 12

This command sets the color of the histogram data and its boundary area to maroon.

Example 2

```
HISTogram:COLor?
```

This query might return `:HISTOGRAM:COLOR:14`, indicating that the color of the histogram data and its boundary is gray.

HISTogram:COUNT

This command clears the count and statistics for the histogram and the histogram source data. If the histogram is on, then counting restarts. This is equivalent to clicking Clear in the Source section of the Histogram Setup dialog box. There is no query form of this command.

Group

Histogram

Syntax

```
HISTogram:COUNT {RESET}
```

Example

```
HISTOGRAM:COUNT RESET
```

Clears the count and statistics for the histogram and the histogram source data.

HISTogram:DISplay

This command sets or queries whether the histogram is displayed. This is equivalent to selecting Histogram in the Display Options section of the Histogram Setup dialog box.

Group

Histogram

Syntax 1

```
HISTogram:DISplay {ON|OFF|NR1}
```

Syntax 2

```
HISTogram:DISplay?
```

Arguments

- ON
This argument displays the histogram.
- OFF
This argument disables the histogram display.
- NR1
A 0 disables the histogram display; any other value displays the histogram.

Example 1

```
HISTogram:DISplay ON
```

This command displays the histogram.

Example 2

`HISTogram:DISplay?`

This query might return `:HISTOGRAM:DISPLAY 0`, indicating that the histogram display is disabled.

NOTE: A query always returns a 0 or 1.

HISTogram:ENABle

This command sets or queries whether the histogram calculations are enabled. This is equivalent to selecting Enable Histogram in the Source section of the Histogram Setup dialog box. Sending this command will cause the histogram statistics to be displayed (but not the histogram). Use the `HISTogram:DISplay` command to control whether the histogram is displayed on screen.

Group

Histogram

Syntax 1

`HISTogram:ENABle {ON|OFF|NR1}`

Syntax 2

`HISTogram:ENABle?`

Arguments

- `ON`
This argument enables histogram calculations.
- `OFF`
This argument disables histogram calculations.
- `NR1`
A 0 disables the histogram calculations; any other value enables histogram calculations.

Example 1

`HISTogram:ENABle ON`

This command enables histogram calculations.

Example 2

`HISTogram:ENABle?`

This query might return `:HISTOGRAM:ENABLE 0`, indicating that the histogram calculations are disabled.

NOTE: A query always returns a 0 or 1.

HISTogram:MODE

Selects the type of histogram to create. This is equivalent to selecting either Vertical or Horizontal in the Source section of the Histogram Setup dialog box.

Group

Histogram

Syntax 1

```
HISTogram:MODE {HORizontal|VERTical}
```

Syntax 2

```
HISTogram:MODE?
```

Arguments

- `HORizontal`
Displays a horizontally positioned histogram that shows time distribution.
- `VERTical`
Displays a vertically positioned histogram that shows a voltage distribution (or other vertical distribution, such as amperes).

Example 1

```
HISTogram:MODE HORizontal
```

Sets the histogram mode to the horizontal display mode.

Example 2

```
HISTogram:MODE?
```

This query might return `:HISTOGRAM:MODE VERTICAL`, indicating that the vertical display mode is selected for the histogram.

HISTogram:SIZE

This command sets or queries the width or height in divisions of the histogram plot on the screen. This is equivalent to setting Size in the Display Options section of the Histogram Setup dialog box.

Group

Histogram

Syntax 1

```
HISTogram:SIZE <NR3>
```

Syntax 2

```
HISTogram:SIZE?
```

Argument

NR3

The value can vary from 1.0 to 10.0 in Horizontal mode and from 1.0 to 10.0 in Vertical mode. Resolution is to the nearest pixel.

Example 1

```
HISTogram:SIZE 2
```

This command sets the size of the histogram to 2 divisions.

Example 2

```
HISTogram:SIZE?
```

This command might return `HISTOGRAM:SIZE 4.000000000000`, indicating the histogram size is set to 4 divisions.

HISTogram:SOUrce

This command sets or queries which source will be compared against the histogram box when the histogram testing is enabled. You can also select the timebase on which to perform testing. If you do not specify a timebase, Main is the default. This is equivalent to selecting the source from the pulldown list in the Source section of the Histogram Setup dialog box. The waveform need not be displayed for histograms to run. You might want the channel displays disabled so you can see a full-screen histogram and not have waveform data confuse the display.

Group

Histogram

Syntax 1

```
HISTogram:SOUrce {CH<x>|MATH<x>|REF<x>}  
[,{MAIn|MAG1|MAG2}]
```

Syntax 2

```
HISTogram:SOUrce?
```

Argument

- `CH<x>`
This argument selects a channel waveform as the source for the histogram. The range for x is 1 through 8.
- `MATH<x>`
This argument selects a math waveform as the source for the histogram. The range for x is 1 through 8.
- `REF<x>`
This argument selects a reference waveform as the source for the histogram. The range for x is 1 through 8.
- `MAIn`
This optional argument selects Main as the timebase for the histogram display.
- `MAG1`
This optional argument selects MAG1 as the timebase for the histogram display.
- `MAG2`
This optional argument selects MAG2 as the timebase for the histogram display.

Example 1

```
HISTogram:SOUrce CH1
```

Enables the Channel 1 waveform to be compared against the histogram box. The default timebase, Main, is used for the histogram display.

Example 2

HISTogram:SOUrce?

This query might return :HISTOGRAM:SOURCE CH1,MAG1, indicating that the waveform for Channel 1 is the source for the histogram and that it is displayed using MAG1 as the timebase.

HISTogram:STATistics:HITS?

This query only command returns the total hits calculated for the histogram. This is the value that is displayed for Hits in the Histogram readout.

Group

Histogram

Syntax

HISTogram:STATistics:HITS?

Example

HISTogram:STATistics:HITS?

This query might return :HISTOGRAM:STATISTICS:HITS 6.83400000000E+003, indicating that the total hits for the histogram is 6,834.

HISTogram:STATistics:MEAN?

This query only command returns the mean value calculated for the histogram. This is the value that is displayed for Mean in the Histogram readout.

Group

Histogram

Syntax

HISTogram:STATistics:MEAN?

Example

HISTogram:STATistics:MEAN?

This query might return :HISTOGRAM:STATISTICS:MEAN 43.0000000000E-009, indicating that the mean value for the horizontal histogram is 43 ns.

HISTogram:STATistics:MEDIAN?

This query only command returns the median value calculated for the histogram. This is the value that is displayed for Median in the Histogram readout.

Group

Histogram

Syntax

HISTogram:STATistics:MEDIAN?

Example

```
HISTogram:STATistics:MEDIAN?
```

This query might return :HISTOGRAM:STATISTICS:MEDIAN
43.0000000000E-009, indicating that the median value for the
horizontal histogram is 43 ns.

HISTogram:STATistics:PEAKHits?

This query only command returns the peak hits calculated for the
histogram. This is the value that is displayed for Peak in the Histogram
readout.

Group

Histogram

Syntax

```
HISTogram:STATistics:PEAKHits?
```

Example

```
HISTogram:STATistics:PEAKHits?
```

This query might return :HISTOGRAM:STATISTICS:PEAKHITS
370.000000000, indicating that the peak hits value calculated for the
waveform is 370.

HISTogram:STATistics:PKTOPK?

This query only command returns the peak-to-peak value calculated for
the histogram. This is the value that is displayed for Pk-Pk in the
Histogram readout.

Group

Histogram

Syntax

```
HISTogram:STATistics:PK2PK?
```

Example

```
HISTogram:STATistics:PK2PK?
```

This query might return :HISTOGRAM:STATISTICS:PKTOPK
20000000000.009, indicating that the peak-to-peak value for the
horizontal histogram is 20 ns

HISTogram:STATistics:SIGMA<x>?

This query only command returns the population densities for $\pm 1\sigma$, $\pm 2\sigma$,
or $\pm 3\sigma$ value (standard deviation from the mean value) calculated for the
histogram. This is the value that is displayed for $\mu \pm 1\sigma$, $\mu \pm 2\sigma$, or $\mu \pm 3\sigma$ in
the Histogram readout.

Group

Histogram

Syntax

`HISTogram:STATistics:SIGMA<x>?`

The value for *x* can be 1, 2, or 3, indicating a query for the sigma1, sigma2, or sigma3 value.

Example

`HISTogram:STATistics:SIGMA1?`

This query might return `:HISTOGRAM:STATISTICS:SIGMA1 58.0060`, indicating that 58% of the hits fall within one standard deviation ($\mu \pm 1\sigma$) from the mean calculated for the histogram.

HISTogram:STATistics:WAVeforms?

This query only command returns the number of waveforms used in the histogram. This is the value that is displayed for Waveforms in the Histogram readout.

Group

Histogram

Syntax

`HISTogram:STATistics:WAVeforms?`

Example

`HISTogram:STATistics:WAVeforms?`

This query might return `:HISTOGRAM:STATISTICS:WAVEFORMS 2.08100000000E+003`, indicating that 2081 waveforms were used to create the histogram.

HISTogram:STATistics?

This query only command returns all histogram statistics. These are the Histogram statistics that are displayed in the Histogram readout:

- Mean
- Median
- Std Dev
- Pk-Pk
- $\mu \pm 1?$
- $\mu \pm 2?$
- $\mu \pm 3?$
- Peak
- Hits
- Waveforms

The histogram statistics (and count) can be reset with the `HISTogram:COUNt` command.

Group

Histogram

Related Commands

HISTogram:COUNT

Syntax

HISTogram:STATistics?

Example

HISTogram:STATistics?

This query might return the following:

```
:HISTOGRAM:STATISTICS:MEAN 43.0000000000E-009;MEDIAN 43.0000000000E-009;STDDEV 5.80230431544E-009;PKTOPK 20.0000000000E-009;SIGMA1 58.7064;SIGMA2 58.7064;SIGMA3 100.0000;PEAKHITS 2.43800000000E+003;HITS 490.0380000000E+003;WAVEFORMS 2.43800000000E+003
```

HISTogram:STATistics:STDdev?

This query only command returns the standard deviation value calculated for the histogram. This is the value that is displayed for Std Dev in the Histogram readout.

Group

Histogram

Syntax

HISTogram:STATistics:STDdev?

Example

HISTogram:STATistics:STDdev?

This query might return :HISTOGRAM:STATISTICS:STDDEV 5.80230767128E-009, indicating that the standard deviation value for the horizontal histogram is 5.80 ns.

HISTogram:TYPE

This command sets or queries whether the histogram is displayed linearly or logarithmically. This is equivalent to selecting Linear or Logarithmic in the Display Options section of the Histogram Setup dialog box.

Group

Histogram

Syntax 1

HISTogram:TYPE {LINEAr|LOG}

Syntax 2

HISTogram:TYPE?

Arguments

- LINEAR

This argument specifies that bin counts smaller than the maximum should be scaled linearly by dividing the bin count by the maximum bin count.

- LOG

This argument specifies that bin counts smaller than the maximum should be scaled logarithmically ($\log(\text{bin-count})$) with $\log(0)$ staying at 0 (baseline). The base of the log does not matter since logs to different bases differ only by a constant multiplier. Logarithmic scaling provides better visual detail for bins with low counts.

Example 1

```
HISTogram:TYPE LINEAR
```

This command displays the count in each bin scaled linearly.

Example 2

```
HISTogram:TYPE?
```

This query might return `:HISTOGRAM:TYPE LINEAR`, indicating that the histogram display is scaled linearly.

HISTogram:WFMDB:STATE

This command sets or queries whether the histogram counting is made on a waveform database created on the source of the histogram. This is equivalent to selecting or clearing the Use Wfm Database check box in the Source section of the Histogram Setup dialog box.

Group

Histogram

Syntax 1

```
HISTogram:WFMDB:STATE {ON|OFF|NR1}
```

Syntax 2

```
HISTogram:WFMDB:STATE?
```

Arguments

- ON

This argument enables histogram counting on a waveform database created on the source of the histogram.

- OFF

This argument disables histogram counting on a waveform database; testing is done "on the fly."

- NR1

A 0 disables the histogram counting on a waveform database; any other value enables histogram counting on a waveform database.

Example 1

```
HISTogram:WFMDB:STATE ON
```

This command enables histogram counting on a waveform database.

Example 2

```
HISTogram:WFMDB:STATE?
```

This query might return `:HISTOGRAM:WFMDB:STATE 0`, indicating that the histogram counting on a waveform database is disabled.

Note: A query always returns 0 or 1.

HISTogram?

This is a query only command that returns histogram parameters; it queries the state of all settable histogram parameters.

Group

Histogram

Syntax

```
HISTogram?
```

Example

```
HISTOGRAM?
```

This command might return

```
:HISTOGRAM:BOX 1.51800000000E-006,-24.4980000000,  
3.51800000000E-006,-74.4980000000;BOXPCNT  
30.0000000000,25.0000000000,  
7.0000000000,7.5000000000;COLOR 6;  
ENABLE 1;DISPLAY 1;TYPE LINEAR;MODE VERTICAL;  
SIZE 4.0000000000;SOURCE CH3,MAIN;  
STATISTICS:MEAN 46.9321597622E-003;  
MEDIAN 224.000000000E-003;STDDEV 227.027807252E-  
003;  
PKTOPK 500.000000000E-003;SIGMA1 636.054733146E-  
003;  
SIGMA2 636.054733146E-003;SIGMA3 1.00000000000;  
PEAKHITS 39.4280000000E+003;HITS  
185.701000000E+003;  
WAVEFORMS 924.000000000;:HISTOGRAM:WFMDB:STATE 1
```

HORizontal:BITS:BITRate

This command sets or queries the bit rate of the timebase. Sending this command is equivalent to setting a value in the Bit Rate control in the All Timebases section of the Horizontal Setup dialog box. This value is used to convert horizontal scales from seconds to bits.

If a communications standard is set by the HORizontal:BITS:STANDARD command, the bit rate is coerced to the bit rate for the specified standard.

Group

Horizontal

Related Commands

HORizontal:BITS:STANdard, HORizontal:UNIts

Syntax 1

```
HORizontal:BITS:BITRate <NR3>
```

Syntax 2

```
HORizontal:BITS:BITRate?
```

Argument

NR3

This argument is the bit rate.

Example 1

```
HORizontal:BITS:BITRate 5.0E6
```

This command sets the bit rate to 5 Mbits per second.

Example 2

```
HORizontal:BITS:BITRate?
```

This query might return :HORIZONTAL:BITS:BITRATE

2.48832000000E+009, indicating that the bit rate is set to 2.488 Gbits per second.

HORizontal:BITS:STANdard

This command sets or queries the communication standard, which determines the bit rate that is used to calculate parameters, such as horizontal position, when HORizontal:UNIts are set to the BITS selection. The seconds-to-bits conversion factors of all timebases are set in accordance with the bit rate associated with the selected communication standard. Sending this command is equivalent to selecting a communication standard for the Com Standard control in the All Timebases section of the Horizontal Setup dialog box.

Note: Setting the HORizontal:BITS:STANdard with this command sets the MASK:STANdard setting to the same argument. Also, setting the horizontal bit rate with the HORizontal:BITS:BITRate command coerces the HORizontal:BITS:STANdard setting to USERMask.

Group

Horizontal

Syntax 1

```
HORizontal:BITS:STANdard {NONE|OC1|OC3|OC9|OC12  
|OC18|OC24|OC36|OC48|FEC2666|OC192|FEC10664  
|FEC10709|OC768|FEC42657|FC133|FC266|FC531  
|FC1063|FC2125|FC4250|FC133E|FC266E|FC531E  
|FC1063E|ENET1250|ENET3125|ENET9953|ENET10313  
|INFIband|USERMask}
```

Syntax 2

```
HORizontal:BITS:STANdard?
```

Arguments

- NONE

Disables the communications standards.

- OC1
Selects the 51.84 Mb/s bit rate, in accordance with the Sonet/SDHOC-1/STM-0 standard.
- OC3
Selects the 155.52 Mb/s bit rate, in accordance with the Sonet/SDHOC-3/STM-1 standard.
- OC9
Selects the 466.56 Mb/s bit rate, in accordance with the Sonet/SDHOC-9/STM-3 standard.
- OC12
Selects the 622.08 Mb/s bit rate, in accordance with the Sonet/SDHOC-12/STM-4 standard.
- OC18
Selects the 933.12 Mb/s bit rate, in accordance with the Sonet/SDHOC-18/STM-6 standard.
- OC24
Selects the 1.24416 Gb/s bit rate, in accordance with the Sonet/SDHOC-24/STM-8 standard.
- OC36
Selects the 1.86624 Gb/s bit rate, in accordance with the Sonet/SDHOC-36/STM-12 standard.
- OC48
Selects the 2.48832 Gb/s bit rate, in accordance with the Sonet/SDHOC-48/STM-16 standard.
- FEC2666
Selects the 2.6660571 Gb/s bit rate, in accordance with the ITU-T G.975 Recommendation
- OC192
Selects the 9.95328 Gb/s bit rate, in accordance with the Sonet/SDHOC192/STM-64 standard.
- FEC10664
Selects the 10.6642 Gb/s bit rate, in accordance with the ITU-T G.975 Recommendation
- FEC10709
Selects the 10.709225 Gb/s bit rate, in accordance with the ITU-T G.709 Draft Recommendation
- OC768
Selects the 39.8131 bit rate, in accordance with the Sonet/SDHOC768/STM-256 standard.
- FEC42657

Selects the 42.6569 Gb/s bit rate, in accordance with the ITU-T G.975 Recommendation

- FC133
Selects the 132.81 Mb/s bit rate, in accordance with the ANSI X3.230-1994 standard.
- FC266
Selects the 265.6 Mb/s bit rate, in accordance with the ANSI X3.230-1994 standard.
- FC531
Selects the 531.2 Mb/s bit rate, in accordance with the ANSI X3.230-1994 standard.
- FC1063
Selects the 1062.5 Gb/s bit rate, in accordance with the ANSI X3.230-1994 standard.
- FC2125
Selects the 2125 Gb/s bit rate, in accordance with the ANSI Fibre Channel Physical Interface (FC-PI) Rev 11 draft standard.
- FC4250
Selects the 4250 Gb/s bit rate, in accordance with the ANSI Fibre Channel Physical Interface (FC-PI) Rev 11 draft standard.
- FC133E
Selects the 132.81 Mb/s bit rate, in accordance with the ANSI X3.230-1994 standard.
- FC266E
Selects the 265.6 Mb/s bit rate, in accordance with the ANSI X3.230-1994 standard.
- FC531E
Selects the 531.2 Mb/s bit rate, in accordance with the ANSI X3.230-1994 standard.
- FC1063E
Selects the 1.0625 Gb/s bit rate, in accordance with the ANSI X3.230-1994 standard.
- ENET1250
Selects the 1.250 Gb/s bit rate, in accordance with the IEEE 802.3 standard.
- ENET3125
Selects the 3.125 Gb/s bit rate, in accordance with the IEEE P802.ae draft standard.
- ENET9953
Selects the 9.95328 Gb/s bit rate, in accordance with the IEEE P802.ae draft standard.

- **ENET10313**
Selects the 10.3125 Gb/s bit rate, in accordance with the IEEE P802.ae draft standard.
- **INFIniband**
Selects the 2.500 Gb/s bit rate, in accordance with the InfiniBand standard.
- **USERMask**
Sets the bit rate in accordance with a user-defined standard.

Example 1

`HORizontal:BITS:STANdard OC192`

This command sets the bit rate to the Sonet/SDH OC-192/STM-64 standard of 9953 Mb/s.

Example 2

`HORizontal:BITS:STANdard?`

This query might return `:HORIZONTAL:BITS:STANDARD OC12`, indicating that the bit rate is set to the Sonet/SDH OC-12/STM-4 standard of 622.1 Mb/s.

HORizontal:DISTance:DIElectric

This command sets or queries the dielectric constant. This is equivalent to setting the Dielectric constant in the Distance section of the Horizontal Setup dialog box.

Group

Horizontal

Related Commands

`HORizontal:UNIts`, `HORizontal:DISTance:PVELocity`,

Syntax 1

`HORizontal:DISTance:DIElectric <NR3>`

Syntax 2

`HORizontal:DISTance:DIElectric?`

Argument

NR3

This argument is the dielectric constant of the material being tested.

HORizontal:DISTance:PVELocity

This command sets or queries the Propagation Velocity. This is equivalent to setting the Propagation Velocity in the Distance section of the Horizontal Setup dialog box.

Group

Horizontal

Related Commands

HORizontal:UNIts, HORizontal:DISTance:DIElectric

Syntax 1

HORizontal:DISTance:PVELocity <NR3>

Syntax 2

HORizontal:DISTance:PVELocity?

Argument

NR3

This argument is the propagation velocity of the material being tested.

HORizontal:EXT10MHZref:FREQ

This command sets or queries the external 10 MHz reference frequency. The command allows you to adjust the external 10 MHz reference frequency to ensure that the timebase locks when the Lock to Ext. 10 MHz mode is set using the HORizontal:TBMmode command.

Group

Horizontal

Related Commands

HORizontal:TBMmode

Syntax 1

HORizontal:EXT10MHZref <NR3>

Syntax 2

HORizontal:EXT10MHZref?

Argument

NR3

This is the external 10 MHz frequency setting. The range for this argument is $1.0E7 \pm 0.1\%$ (9.99 MHz through 10.01 MHz). The resolution is 0.1 Hz. The default is 10 MHz.

Example 1

HORizontal:EXT10MHZref 9.999E6

This command sets the horizontal external 10 MHz frequency to 9.999 MHz.

Example 2

HORizontal:EXT10MHZref?

This query might return :HORIZONTAL:EXT10MHZREF:FREQ 10.000000000E+006, indicating that the horizontal external 10 MHz frequency is set to the default value.

HORizontal:FRAMescan:AUTOPosition

This command sets or queries whether or not Auto Position is enabled when in FrameScan mode. When Auto Position is enabled, the

FrameScan mode starts scanning with an initial horizontal position specified by the start bit set by the `HORizontal:FRAMescan:STARTBit` command. Otherwise, scanning starts at the current horizontal bit location. Sending this command is equivalent to checking the Auto Position box in the FrameScan section of the Horizontal Setup dialog box.

Group

Horizontal

Related Commands

`HORizontal:FRAMescan:STARTBit`

Syntax 1

```
HORizontal:FRAMescan:AUTOPosition {ON|OFF|NR1}
```

Syntax 2

```
HORizontal:FRAMescan:AUTOPosition?
```

Argument

- ON
This argument enables Auto Position mode, which starts the scan at the start bit specified by the `HORizontal:FRAMescan:STARTBit` command.
- OFF
This argument disables Auto Position. Scanning will start at the current horizontal bit location.
- NR1
A 0 disables Auto Position; any other value enables Auto Position.

Example 1

```
HORizontal:FRAMescan:AUTOPosition 1
```

This command enables Auto Position.

Example 2

```
HORizontal:FRAMescan:AUTOPosition?
```

This query might return

```
:HORIZONTAL:FRAMESCAN:AUTOPOSITION 0, indicating that  
Auto Position is disabled.
```

NOTE: A query always returns a 0 or 1.

HORizontal:FRAMescan:RESET

This command (no query form) resets and restarts the FrameScan acquisition at the specified start bit. Sending this command is equivalent to clicking the Reset button in the FrameScan section of the Horizontal Setup dialog box. You can set the start bit with the `HORizontal:FRAMescan:STARTBit` command.

Group

Horizontal

Syntax

```
HORizontal:FRAMescan:RESET
```

Example

```
HORizontal:FRAMescan:RESET
```

This command resets and restarts the FrameScan acquisition at the specified start bit.

HORizontal:FRAMescan:SCANBits

This command sets or queries the number of bits or subframes to scan in the FrameScan mode. Sending this command is equivalent to setting a value in the Scan Bits control in the FrameScan section of the Horizontal Setup dialog box.

Scanning will begin at either the start bit specified with the HORizontal:FRAMescan:STARTBit command or the current horizontal bit location. The minimum value of bits to scan is 1 and the maximum value is $2^{20}-1$.

Group

Horizontal

Related Commands

```
HORizontal:FRAMescan:STARTBit
```

Syntax 1

```
HORizontal:FRAMescan:SCANBits <NR1>
```

Syntax 2

```
HORizontal:FRAMescan:SCANBits?
```

Argument

NR1

This argument sets the number of bits to be scanned in FrameScan mode. The range is 1 through 1,048,575 bits.

Example 1

```
HORizontal:FRAMescan:SCANBits 4000
```

This command sets the number of bits scanned in the FrameScan mode to 4000.

Example 2

```
HORizontal:FRAMescan:SCANBits?
```

This query might return :HORIZONTAL:FRAMESCAN:SCANBITS 700, indicating the number of scan bits is set to 700.

HORizontal:FRAMescan:STARTBit

This command sets or queries the bit number of the first bit scanned in the FrameScan Acquisition mode when Auto Position mode is enabled. The Start Bit value is used to help determine the Horizontal Position when FrameScan starts. The start bit setting may be a noninteger number and has a minimum value determined by the minimum hardware

insertion delay multiplied by the selected bit rate. There is no interaction with Scan Bits. Sending this command is equivalent to setting a value in the Start Bit control in the FrameScan section of the Horizontal Setup dialog box.

Group

Horizontal

Related Commands

HORizontal:FRAMescan:AUTOPosition

Syntax 1

HORizontal:FRAMescan:STARTBit <NR3>

Syntax 2

HORizontal:FRAMescan:STARTBit?

Argument

NR3

This argument specifies the starting bit location for the scan.

Example 1

HORizontal:FRAMescan:STARTBit 200

This command sets the first bit scanned to 200.

Example 2

HORizontal:FRAMescan:STARTBit?

This query might return :HORIZONTAL:FRAMESCAN:STARTBIT 45.000000000E+003, indicating that the first bit scanned in FrameScan mode when Auto Position is enabled is bit 450.

HORizontal:FRAMescan:STATE

This command sets or queries the FrameScan mode. Scanning starts as soon as you enable FrameScan. Sending this command is equivalent to checking Enabled in the FrameScan section of the Horizontal Setup dialog box.

FrameScan acquisitions allow detailed display and analysis of individual, complete waveforms or of the bit sequences leading up to a failure. This ability to identify the specific patterns that cause the failures makes using FrameScan mode superior to traditional methods of analyzing pattern-dependent failures in high bit rate communications signals.

Refer to the online help and the user manual for this instrument for additional information about FrameScan.

Group

Horizontal

Syntax 1

HORizontal:FRAMescan:STATE {ON|OFF|NR1}

Syntax 2

HORizontal:FRAMescan:STATE?

Arguments

- ON
This argument enables the FrameScan mode.
- OFF
This argument disables the FrameScan mode.
- NR1
A 0 disables the FrameScan mode; any other value enables the FrameScan mode.

Example 1

```
HORizontal:FRAMescan:STATE ON
```

This command enables the FameScan mode.

Example 2

```
HORizontal:FRAMescan:STATE?
```

This query might return `:HORIZONTAL:FRAMESCAN:STATE 0`, indicating that the FrameScan mode is currently disabled.

NOTE: A query always returns a 0 or 1.

HORizontal:MAG<x>:POSITION

This command sets or queries the horizontal position for the specified Mag timebase. The Mag timebase is specified by *x*, which can be 1 or 2. Sending this command is equivalent to selecting a Mag timebase and entering a value in the Position control in the Timebase section of the Horizontal Setup dialog box or adjusting the front-panel Horizontal POSITION control.

This command sets a delay time (or distance) for the specified Mag channel waveforms between the trigger event and the horizontal reference point for the Mag timebase, which is set with the `HORizontal:MAG<x>:REFPoint` command. The minimum position you can set is limited to one of the following settings, depending on the current hardware configuration:

- If there are no sampling modules on extender cables, the minimum horizontal position is set to 19 ns. This is the typical value, not the actual hardware minimum value (insertion delay, or the minimum time from an external trigger event to the first acquired sample).
- If there are one or more sampling modules on extender cables, then the minimum horizontal position is set to 19 ns plus the maximum delay of the extender cables. The minimum horizontal position governs the smallest horizontal position you can set. Changing the main timebase position can affect the position of each Mag timebase; however, Mag timebase positions cannot affect the main timebase position.
- Mag acquisitions are contained within the Main timebase acquisitions.

Refer to the illustration below for a diagram of the relationships of horizontal position, horizontal reference point, time of first point, and time of last point.

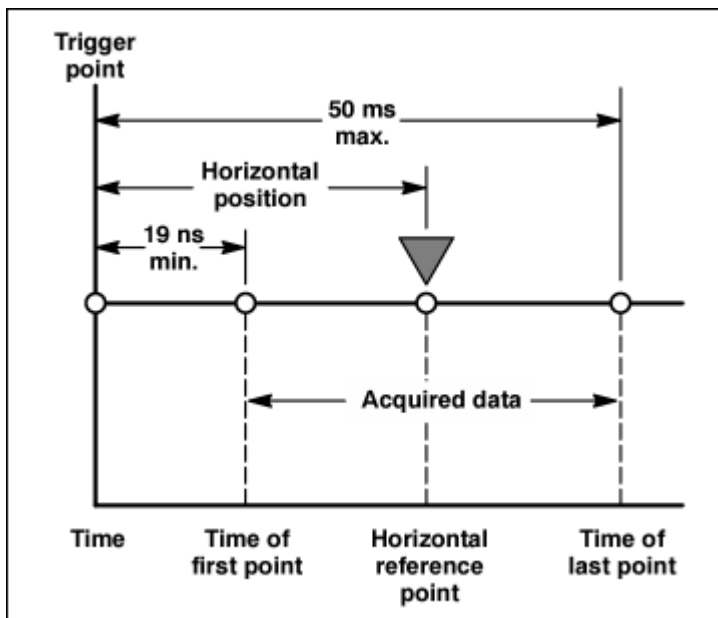

The position of the Mag timebase is constrained to be in the domain of the Main timebase. Changing the Main timebase position can affect the position of each Mag timebase, but a Mag timebase position cannot affect the Main timebase position.

Group

Horizontal

Related Commands

HORizontal:MAG<x>:REFPoint, HORizontal:MAG<x>:TOFPoint,
HORizontal:MAG<x>:TOLPoint

Syntax 1

HORizontal:MAG<x>:POSition <NR3>

Syntax 2

HORizontal:MAG<x>:POSition?

Argument

NR3

This argument is the horizontal position value for the specified Mag timebase. The range is from a typical value of 19 ns to 50 ms. The minimum value will be equal to or greater than the insertion delay (see bulleted item above).

Example 1

HORizontal:MAG1:POSition 5.0E-8

This command attempts to set the horizontal position for the Mag1 timebase to 50 ns. (If the Main timebase does not cover the time window, the Mag horizontal position will be coerced.)

Example 2

```
HORizontal:MAG2:POSition?
```

This query might return :HORIZONTAL:MAGNIFY2:POSITION 84.0000000000E-009, indicating that the horizontal position for the MAG2 timebase is set to a time of 84 ns relative to the trigger.

HORizontal:MAG<x>:RECORDLength

This command sets or queries the record length for the specified Mag timebase. The Mag timebase is specified by x, which can be 1 or 2. Sending this command is equivalent to selecting a Mag timebase and then setting a value for the Record Length control in the Timebase section of the Horizontal Setup dialog box.

The instrument displays the waveform within the 10 horizontal divisions on screen. The values you can set for record length are 20, 50, 100, 250, 500, 1000, 2000, and 4000 samples.

Record length can be constrained by the horizontal scale. The minimum sample interval is 10 fs. Therefore, (10 X Horizontal Scale)÷Record Length must be greater than or equal to 10 fs. For example, if the horizontal scale is equal to 1 ps/div, the maximum record length is 1000 points.

Group

Horizontal

Related Commands

HORizontal:MAG<x>:SCALE, HORizontal:MAG<x>:RESolution?

Syntax 1

```
HORizontal:MAG<x>:RECORDLength <NR1>
```

Syntax 2

```
HORizontal:MAG<x>:RECORDLength?
```

Argument

NR1

This argument is the record length; valid record lengths are 20, 50, 100, 250, 500, 1000, 2000, and 4000 samples.

Example 1

```
HORizontal:MAG2:RECORDLength 1000
```

This command sets the Mag 2 timebase record length to 1000 samples.

Example 2

```
HORizontal:MAG<x>:RECORDLength?
```

This query might return

:HORIZONTAL:MAGNIFY1:RECORDLENGTH 4000, indicating that the record length for the Mag 1 timebase is set to 4000 samples.

HORizontal:MAG<x>:REFPoint

This command sets or queries the horizontal reference point for the specified Mag timebase. The Mag timebase is specified by *x*, which can be 1 or 2. The horizontal reference point is the horizontal position around which the HORizontal:MAG<x>:SCALE command contracts or expands the waveform, which affects the acquired and observable horizontal window of data. Also, it represents the point that determines the horizontal position of the record from the trigger. The horizontal reference position is set as a fraction of the record; 0.5 (50% of the record) is the default.

This command is equivalent to selecting a Mag timebase and setting a value in the Horizontal Reference control in the Timebase section of the Horizontal Setup dialog box or moving the Horizontal Reference Point indicator at the top of the Mag view.

Refer to the illustration below for a diagram of the relationships of horizontal reference point, time of first point, time of last point, and horizontal position.

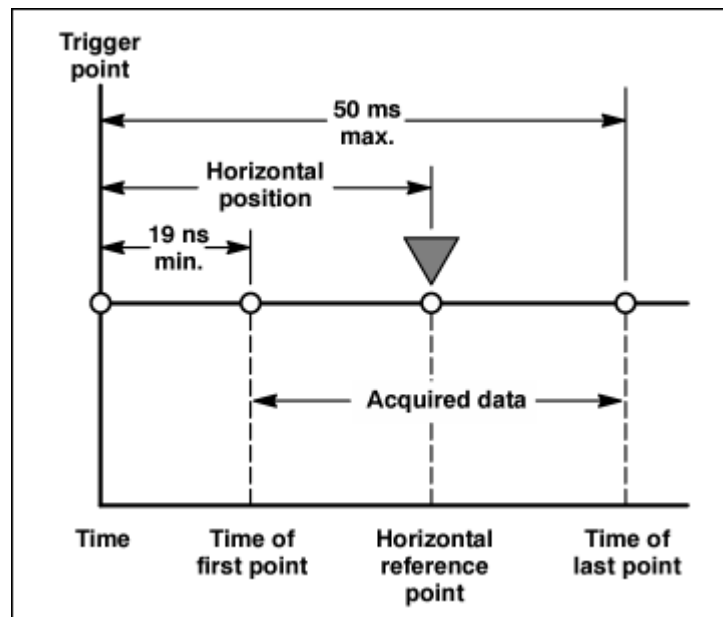

Group

Horizontal

Related Commands

HORizontal:MAG<x>:SCALE

Syntax 1

```
HORizontal:MAG<x>:REFPoint <NR2>
```

Syntax 2

```
HORizontal:MAG<x>:REFPoint?
```

Argument

NR2

This is the fraction of the record at which the horizontal reference point is set. The range is 0 through 1 (corresponding to 0% through 100% of record); the default is 0.5. The resolution is 0.01.

Example 1

```
HORizontal:MAG1:REFPoint 2.5E-1
```

This sets the horizontal reference point for the Mag1 timebase to 0.25 (25%). This is the point around which the HORizontal:MAG:SCALE command contracts or expands the waveform.

Example 2

```
HORizontal:MAG2:REFPoint?
```

This query might return :HORIZONTAL:MAGNIFY2:REFPOINT .500000000000, indicating that the horizontal reference point for the Mag2 timebase is set to 0.5 (50%), which is the default.

HORizontal:MAG<x>:RESolution?

This query only command returns the current resolution per sample of the specified Mag timebase. The Mag timebase is specified by x, which can be 1 or 2. The resolution for the selected timebase is displayed in the Resolution field in the Timebase section of the Horizontal Setup dialog box. You cannot directly set the resolution. Instead, use the HORizontal:MAG<x>:SCALE command to set the horizontal scale and the HORizontal:MAG<x>:RECORDLength command to set the record length. Resolution is displayed in horizontal units, typically time.

Group

Horizontal

Related Commands

HORizontal:MAG<x>:SCALE, HORizontal:MAG<x>:RECORDLength

Syntax

```
HORizontal:MAG<x>:RESolution?
```

Example

```
HORizontal:MAG1:RESolution?
```

This query might return :HORIZONTAL:MAGNIFY1:RESOLUTION 6.31000000000E-012, indicating that the resolution is 6.31 ps.

HORizontal:MAG<x>:SCALE

This command sets or queries the scale (time per division) for the specified Mag timebase. The Mag timebase is specified by x, which can be 1 or 2. Sending this command is equivalent to selecting a Mag timebase and adjusting the Scale control in the Timebase section of the Horizontal Setup dialog box (or adjusting the Horizontal SCALE front-panel knob).

Channel waveforms display in the Mag timebases with the horizontal scale set for the timebase. Each channel timebase, Main, Mag1, and Mag2, uses its own horizontal scale. All channel waveforms in an individual timebase share the timebase scale. The horizontal scale, together with the record length setting, determines the sample interval. Main, Mag1, and Mag2 timebase scales, positions, and record lengths (resolution) are independent of one another; however, acquisitions on Mag timebases must be totally contained within the Main timebase.

Scale can be constrained by the record length. The minimum sample interval is 10 fs. Therefore, $(10 \times \text{Horizontal Scale}) \div \text{Record Length}$ must be greater than or equal to 10 fs. For example, if the record length is equal to 4000 samples, the horizontal scale must be greater than or equal to 4 ps/div.

Group

Horizontal

Related Commands

HORizontal:MAG<x>:RECORDLength,
HORizontal:MAG<x>:RESolution, HORizontal:MAG<x>:REFPoint,
HORizontal:MAG<x>:POSition

Syntax 1

```
HORizontal:MAG<x>:SCALE <NR3>
```

Syntax 2

```
HORizontal:MAG<x>:SCALE?
```

Argument

NR3

This argument is the horizontal time per division for the specified Mag timebase. The range is 1 ps per division to 5 ms per division.

Example 1

```
HORIZONTAL:MAG1:SCALE 2E-6
```

Sets the MAG1 scale to 2 μ s per division.

Example 2

```
HORIZONTAL:MAG2:SCALE?
```

This query might return :HORIZONTAL:MAGNIFY2:SCALE
2.000000000000E-009, indicating that the Mag2 timebase is currently set to 2 ns per division.

HORizontal:MAG<x>:TOFFPoint?

This query only command returns time of first point for the specified Mag timebase, which is the time interval between the trigger point and the first point in the specified Mag timebase record (waveform). The Mag timebase is specified by x, which can be 1 or 2.

Refer to the illustration below for a diagram of the relationships of time of first point, time of last point, horizontal position, and horizontal reference point.

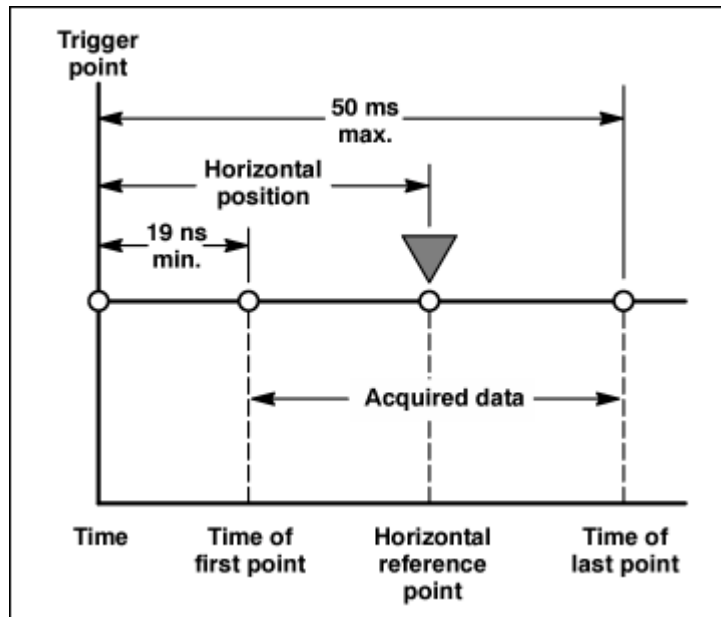

Group

Horizontal

Related Commands

HORizontal:MAG<x>:POSition, HORizontal:MAG<x>:REFPoint,
HORizontal:MAG<x>:SCALE

Syntax

HORizontal:MAG<x>:TOFPoint?

Example

HORizontal:MAG<x>:TOFPoint?

This query might return :HORIZONTAL:MAG1:TOFPOINT
50.000000000E-9, indicating that the time interval between the
trigger point and the first point in the Mag1 timebase record is 50 ns.

HORizontal:MAG<x>:TOLPoint?

This query only command returns time of last point for the specified Mag timebase, which is the time interval between the trigger point and the last point in the specified Mag timebase record (waveform).

Refer to the illustration below for a diagram of the relationships of time of last point, time of first point, horizontal position, and horizontal reference point.

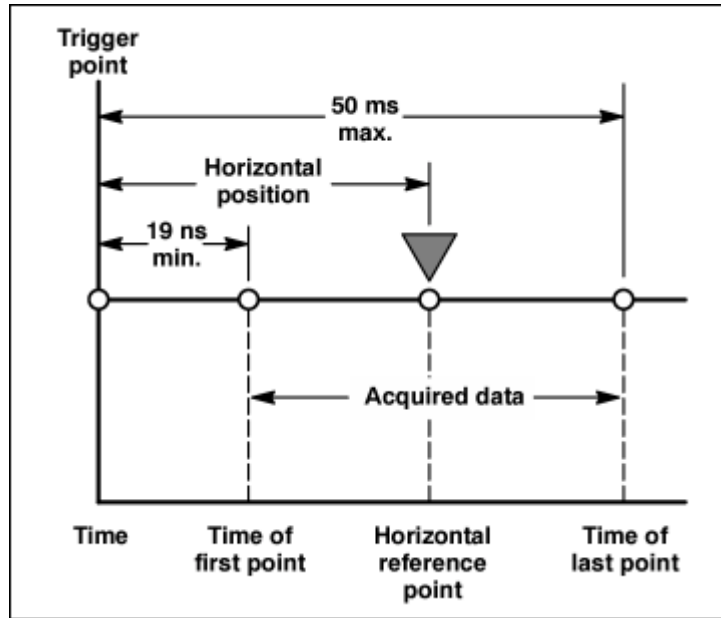

Group

Horizontal

Syntax

HORizontal:MAG<x>:TOLPoint?

Example

HORizontal:MAG2:TOLPoint?

This query might return :HORIZONTAL:MAG2:TOLPOINT
10.000000000E-3, indicating that the time interval between the trigger point and the last point in the Mag2 timebase record is 100 μ s.

HORizontal:MAG<x>:VIEW

This command sets or queries whether the specified Mag timebase is displayed. The Mag timebase is specified by x, which can be 1 or 2. Sending this command is equivalent to clicking the Mag1 or Mag2 icon located below the graticule area of the display or pressing equivalent buttons on the front panel.

Group

Horizontal

Syntax 1

HORizontal:MAG<x>:VIEW {ON|OFF|NR1}

Syntax 2

HORizontal:MAG<x>:VIEW?

Arguments

- ON
This argument turns on the view of the specified Mag timebase.

- OFF
This argument turns off the view of the specified Mag timebase.
- NR1
A 0 disables the specified Mag timebase view; any other integer enables the specified Mag timebase view.

Example 1

```
HORizontal:MAG2:VIEW ON
```

This command displays the Mag2 timebase.

Example 2

```
HORizontal:MAG1:VIEW?
```

This query might return `:HORIZONTAL:MAGNIFY1:VIEW 0`, indicating that the display of the Mag1 timebase is disabled.

NOTE: A query always returns a 0 or 1.

HORizontal:MAG<x>?

This query only command returns the timebase settings for the specified Mag timebase. The Mag timebase is specified by x, which can be 1 or 2.

Group

Horizontal

Syntax

```
HORizontal:MAG<x>?
```

Example

```
HORizontal:MAG1?
```

This query might return

```
:HORIZONTAL:MAGNIFY1:SCALE 1.05200000000E-009;
POSITION 64.0380000000E-009;RESOLUTION
5.26000000000E-012;RECORDLENGTH 2000;REFPOINT
0.00000000000;VIEW 1;
TOLPOINT 74.5580000000E-009;
TOFPOINT 64.0380000000E-009.
```

HORizontal:MAIn:POSition

This command sets or queries the horizontal position for the Main timebase. Sending this command is equivalent to selecting MainTB and entering a value in the Position control in the Timebase section of the Horizontal Setup dialog box or adjusting the front-panel Horizontal POSITION control.

This command sets a global delay time (or distance) for all channel waveforms between the trigger event and the horizontal reference point for the Main timebase, which is set with the `HORizontal:MAIn:REFPoint` command. The minimum position you can set is limited to one of two settings, depending on the current hardware configuration:

- If there are no sampling modules on extender cables, the minimum horizontal position is set to 19 ns. This is the typical value, not the actual hardware minimum value (insertion delay, or the minimum time from an external trigger event to the first acquired sample).
- If there are one or more sampling modules on extender cables, then the minimum horizontal position is set to 19 ns plus the maximum delay of the extender cables. The minimum horizontal position governs the smallest horizontal position you can set. Changing the main timebase position can affect the position of each Mag timebase; however, Mag timebase positions cannot affect the main timebase position.

Refer to the illustration below for a diagram of the relationships of horizontal position, horizontal reference point, time of first point, and time of last point.

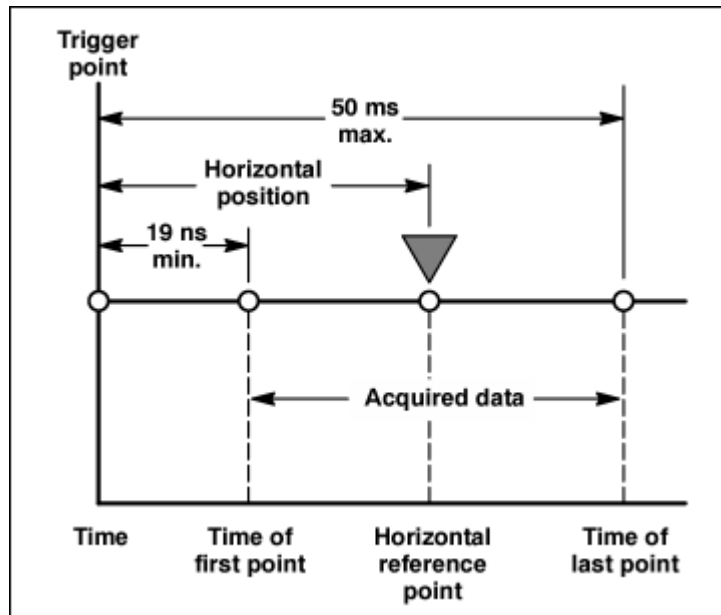

Group

Horizontal

Related Commands

HORizontal:MAIn:REFPoint, HORizontal:MAIn:TOFPoint?,
HORizontal:MAIn:TOLPoint?

Syntax 1

HORizontal:MAIN:POSition <NR3>

Syntax 2

HORizontal:MAIN:POSition?

Argument

NR3

This argument is the horizontal position value for the Main timebase. The range is from a typical value of 19 ns to 50 ms. The minimum value will be equal to or greater than the insertion delay (see bulleted item above).

Example 1

```
HORizontal:MAIN:POSition 1.0E-7
```

This command sets the horizontal position for the Main timebase to 100 ns.

Example 2

```
HORizontal:MAIN:POSition?
```

This query might return :HORIZONTAL:MAIN:POSITION 95.0000000000E-009, indicating that the horizontal position for the Main timebase is set to 95 ns.

HORizontal:MAIn:RECORDlength

This command sets or queries the record length for the Main timebase. This is equivalent to selecting MainTB and then setting a value for the Record Length control in the Timebase section of the Horizontal Setup dialog box.

The instrument displays the waveform within the 10 horizontal divisions on screen. The values you can set for record length are 20, 50, 100, 250, 500, 1000, 2000, and 4000 samples. The default is 500 samples.

Because the waveform must display within 10 horizontal divisions, not all record length settings are valid at all horizontal scales. More specifically:

- SI (sample interval) = TD (Time Duration) / RL (Record Length in samples)
- $TD = 10$ divs (window) x Horizontal scale (Time/div)
- If RL or TD vary, SI varies to accommodate up to highest sample rate.

SI is limited to its lowest value (10 fs). Record length cannot increase for certain scale values, so that SI does not decrease below the 10 fs limit.

The equation becomes:

$$\text{Max } RL = (10 \times \text{Horizontal scale}) / SI, \text{ with div } \times \text{ sec/div } \times \text{ samples/sec, which yields samples } (10 \text{ divs } \times \text{ sec/div}) / \text{Min } SI \text{ (sec/sample).}$$

For example, at 1 ps/div and 10 divisions, the record length must be ≤ 1000 .

Group

Horizontal

Related Commands

HORizontal:MAIn:SCAle, HORizontal:MAIn:RESolution

Syntax 1

`HORizontal:MAIn:RECORDlength <NR1>`

Syntax 2

`HORizontal:MAIn:RECORDlength?`

Argument

NR1

This argument is the record length; valid record lengths are 20, 50, 100, 250, 500, 1000, 2000, and 4000 samples.

Example 1

`HORizontal:MAIn:RECORDlength 500`

This command sets the record length for the Main timebase to 500 samples.

Example 2

`HORizontal:MAIn:RECORDlength?`

This query might return `:HORIZONTAL:MAIN:RECORDLENGTH 1000`, indicating that the record length for the Main timebase is set to 1000 samples.

HORizontal:MAIn:REFPoint

This command sets or queries the horizontal reference point for the Main timebase. The horizontal reference point is the horizontal position around which the `HORizontal:MAIn:SCALE` command contracts or expands the waveform, which affects the acquired and observable horizontal window of data. The horizontal reference position is set as a fraction of the record; 0.5 (50% of the record) is the default.

This command is equivalent to setting a value in the Horizontal Reference control in the Timebase section of the Horizontal Setup dialog box or moving the Horizontal Reference Point indicator at the top of the Main view.

Refer to the illustration below for a diagram of the relationships of horizontal reference point, time of first point, time of last point, and horizontal position.

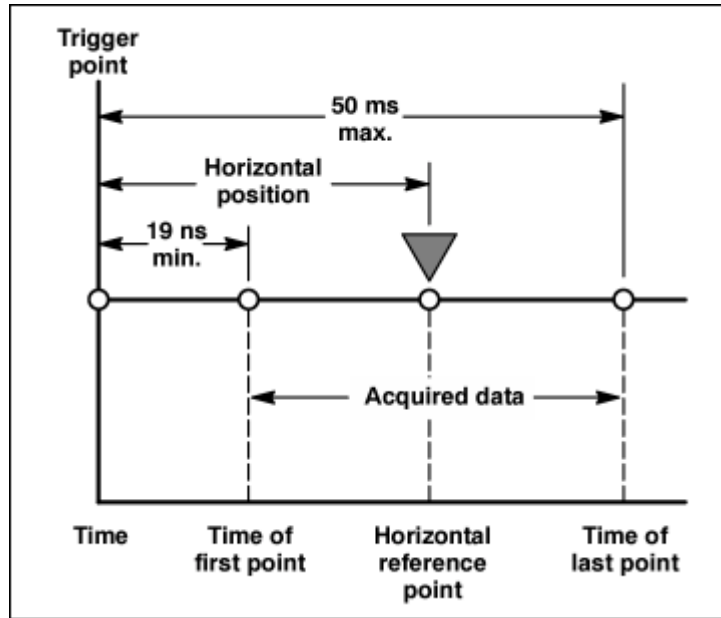

Group

Horizontal

Related Commands

HORizontal:MAIn:POSition

Syntax 1

```
HORizontal:MAIn:REFPoint <NR2>
```

Syntax 2

```
HORizontal:MAIn:REFPoint?
```

Argument

NR2

This is the fraction of the record at which the horizontal reference point is set. The range is 0 through 1 (corresponding to 0% through 100% of record); the default is 0.5. The resolution is 0.01.

Example 1

```
HORizontal:MAIn:REFPoint 2.5E-1
```

This sets the horizontal reference point for the Main timebase to 0.25 (25%). This is the point around which the HORizontal:MAIn:SCALE command contracts or expands the waveform.

Example 2

```
HORizontal:MAIn:REFPoint?
```

This query might return :HORizontal:MAIn:REFPOINT .50000000000, indicating that the horizontal reference point for the Main timebase is set to 0.5 (50%), which is the default.

HORizontal:MAIn:RESolution?

This query only command returns the current resolution per sample of the Main timebase. This value is the same as the value displayed in the Resolution field in the Timebase section of the Horizontal Setup dialog box. You cannot directly set the resolution. Instead, the use the HORizontal:MAIn:SCAle command to set the horizontal scale and the HORizontal:MAIn:RECORDLength command to set the record length. Resolution is displayed in horizontal units, typically time.

Group

Horizontal

Related Commands

HORizontal:MAIn:SCAle, HORizontal:MAIn:RECORDLength,

Syntax

```
HORizontal:MAIn:RESolution?
```

Example

```
HORizontal:MAIn:RESolution?
```

This query might return :HORIZONTAL:MAIN:RESOLUTION 25.0000000000E-012, indicating that the horizontal resolution for the Main timebase is 25 ps.

HORizontal:MAIn:SCAle

This command sets or queries the scale (time per division) for the Main timebase. Sending this command is equivalent to selecting MainTB and adjusting the Scale control in the Timebase section of the Horizontal Setup dialog box.

The horizontal scale that you set with this command is common to all channel waveforms using the Main timebase. The horizontal scale, together with the record length setting, determines the sample interval.

Group

Horizontal

Related Commands

HORizontal:MAIn:RECORDlength, HORizontal:MAIn:RESolution

Syntax 1

```
HORizontal:MAIn:SCAle <NR3>
```

Syntax 2

```
HORizontal:MAIn:SCAle?
```

Argument

NR3

This argument is the horizontal time per division for the Main timebase. The range is 1 ps per division to 5 ms per division.

Example 1

```
HORIZONTAL:MAIN:SCALE 2.0E-9
```

This command sets the main scale to 2 ns per division.

Example 2

```
HORIZONTAL:MAIN:SCALE?
```

This query might return :HORIZONTAL:MAIN:SCALE
10.0000000000E-009, indicating that the Main timebase is
currently set to 10 ns per division.

HORizontal:MAIn:TOFPoint?

This query only command returns time of first point, which is the time interval between the trigger point and the first point in a Main timebase record (waveform).

Refer to the illustration below for a diagram of the relationships of time of first point, time of last point, horizontal position, and horizontal reference point.

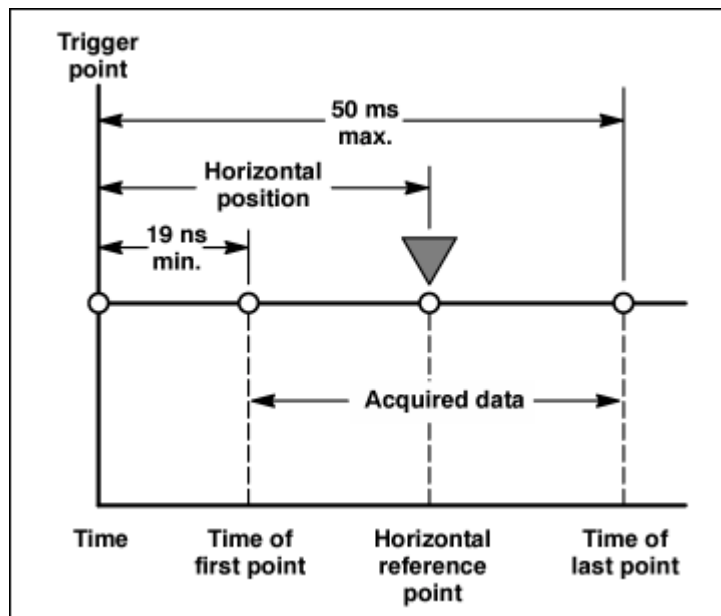

Group

Horizontal

Related Commands

HORizontal:MAIn:POSition, HORizontal:MAIn:REFPoint,
HORizontal:MAIn:SCAlE

Syntax

```
HORizontal:MAIn:TOFPoint?
```

Example

```
HORizontal:MAIn:TOFPoint?
```

This query might return :HORIZONTAL:MAIN:TOLPOINT 20.3000000000E-009, indicating that the time interval between the trigger point and the first point in the Main timebase record is 20.3 ns.

HORizontal:MAIn:TOLPoint?

This query only command returns time of last point, which is the time interval between the trigger point and the last point in a Main timebase record (waveform).

Refer to the illustration below for a diagram of the relationships of time of last point, time of first point, horizontal position, and horizontal reference point.

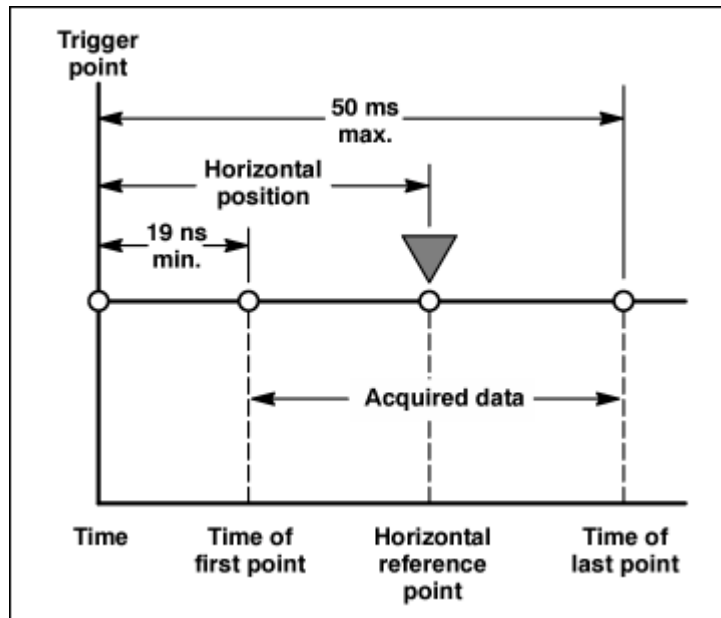

Group

Horizontal

Syntax

HORizontal:MAIn:TOLPoint?

Example

HORizontal:MAIn:TOLPoint?

This query might return :HORIZONTAL:MAIN:TOLPOINT 40.3000000000E-009, indicating that the time interval between the trigger point and the last point in the Main timebase record is 40.3 ns.

HORizontal:MAIn?

This query only command returns the settings of the main time base.

Group

Horizontal

Syntax

HORizontal:MAIn?

Example

HORIZONTAL:MAIN?

This command might return

```
:HORIZONTAL:MAIN:SCALE 2.000000000000E-009;  
POSITION 20.300000000000E-009;  
RESOLUTION 5.000000000000E-012;RECORDLENGTH 4000;  
REFPOINT 0.000000000000;  
TOLPOINT 40.300000000000E-009;  
TOFPOINT 20.300000000000E-009.
```

HORizontal:MATH<x>:MAG<x>:POSition?

This query only command returns the horizontal position of the specified math waveform using the specified Mag timebase. The math waveform is specified by x, which can be 1 through 8; the Mag timebase is specified by x, which can be 1 or 2.

Group

Horizontal

Syntax

HORizontal:MATH<x>:MAG<x>:POSition?

Example

HORizontal:MATH1:MAG2:POSition?

This query might return

```
:HORIZONTAL:MATH1:MAGNIFY2:POSITION  
19.000000000000E-009, indicating that the horizontal position of the  
Math 2 waveform using the MAG2 timebase is set to the minimum time  
of 19 ns.
```

HORizontal:MATH<x>:MAG<x>:RECORDLength?

This query only command returns the record length of the specified Mag timebase for the specified math waveform. The value of the record length can be 20, 50, 100, 250, 500, 1000, 2000, and 4000 samples. It results from normalizing the sources of a math waveform.

Group

Horizontal

Related Commands

HORizontal:MATH<x>:MAG<x>:SCALE?,
HORizontal:MATH<x>:MAG<x>:RESolution?

Syntax

HORizontal:MATH<x>:MAG<x>:RECORDLength?

Example

HORizontal:MATH5:MAG2:RECORDLength?

This query might return
:HORIZONTAL:MATH5:MAGNIFY2:RECORDLENGTH 1000,
indicating that the record length of the Mag 2 timebase is set to 1000
samples for the Math 5 waveform.

HORizontal:MATH<x>:MAG<x>:RESolution?

This query only command returns the resolution per sample of the specified Mag timebase for the specified math waveform. The math waveform is specified by x, which can be 1 through 8; the Mag timebase is specified by x, which can be 1 or 2. Resolution is displayed in horizontal units, typically time.

Group

Horizontal

Related Commands

HORizontal:MATH<x>:MAG<x>:SCALE,
HORizontal:MATH<x>:MAG<x>:RECORDLength?

Syntax

HORizontal:MATH<x>:MAG<x>:RESolution?

Example

HORizontal:MATH1:MAG1:RESolution?

This query might return
:HORIZONTAL:MATH1:MAGNIFY1:RESOLUTION
1.000000000000E-009, indicating that the resolution of the Mag1
timebase for the Math1 waveform is 1 ns.

HORizontal:MATH<x>:MAG<x>:SCALE?

This query only command returns the scale (time per division) of the specified Mag timebase for the specified math waveform. The math waveform is specified by x, which can be 1 through 8; the Mag timebase is specified by x, which can be 1 or 2.

Math waveforms derive their timebase settings from the waveform sources that define them. Math scale is inherited from the live channel source of the math waveform or the saved reference waveforms, if there are no live channel waveforms in the math expression.

Group

Horizontal

Related Commands

HORizontal:MAG<x>:RECORDlength,
HORizontal:MAG<x>:RESolution

Syntax

HORizontal:MATH<x>:MAG<x>:SCALE?

Example

HORIZONTAL:MATH2:MAG2:SCALE?

This query might return `:HORIZONTAL:MATH1:MAGNIFY1:SCALE 30.000000000000E-009`, indicating that the Mag1 timebase is currently set to 30 ns per division for the Math 1 waveform.

HORizontal:MATH<x>:MAG<x>:TOFPoint?

This query only command returns the time of first point of the specified math waveform using the specified Mag timebase. The math waveform is specified by x, which can be 1 through 8; the Mag timebase is specified by x, which can be 1 or 2. The time of first point is the time interval between the trigger point and the first point in the specified Mag timebase record (waveform).

Group

Horizontal

Related Commands

HORizontal:MATH<x>:MAG<x>:POSition?,
HORizontal:MATH<x>:MAG<x>:SCAle?

Syntax

HORizontal:MATH<x>MAG<x>:TOFPoint?

Example

HORizontal:MATH4:MAG1:TOFPoint?

This query might return

`:HORIZONTAL:MATH4:MAGNIFY1:TOFPOINT`

`50.000000000000E-009`, indicating that the time interval between the trigger point and the first point in the Math 4 waveform record using the Mag1 timebase is 50 ns.

HORizontal:MATH<x>:MAG<x>:TOLPoint

This query only command returns time of last point of the specified math waveform using the specified Mag timebase. The math waveform is specified by x, which can be 1 through 8; the Mag timebase is specified by x, which can be 1 or 2. The time of last point is the time interval between the trigger point and the last point in the specified Mag timebase record (waveform).

Group

Horizontal

Related Commands

HORizontal:MATH<x>:MAG<x>:POSition?,
HORizontal:MATH<x>:MAG<x>:SCAle?

Syntax

HORizontal:MATH<x>:MAG<x>:TOLPoint?

Example

HORizontal:MATH2:MAG2:TOLPoint?

This query might return :HORIZONTAL:MAGNIFY2:TOLPOINT 1.00000000000E-9, indicating that the time interval between the trigger point and the last point in the Math 2 waveform record using the Mag2 timebase is 1 ns.

HORizontal:MATH<x>:MAIn:POSition?

This query only command returns the horizontal position of the specified math waveform using the Main timebase. The math waveform is specified by x, which can be 1 through 8.

Group

Horizontal

Related Commands

HORizontal:MATH<x>:MAIn:REFPoint?,
HORizontal:MATH<x>:MAIn:TOFPoint?,
HORizontal:MATH<x>:MAIn:TOLPoint?

Syntax

HORizontal:MATH<x>:MAIN:POSition?

Example

HORizontal:MATH8:MAIN:POSition?

This query might return :HORIZONTAL:MATH8:MAIN:POSITION 19.00000000000E-009, indicating that the horizontal position of the Math 8 waveform using the Main timebase is set to the minimum time of 19 ns.

HORizontal:MATH<x>:MAIn:RECORDLength?

This query only command returns the record length of the Main timebase for the specified math waveform. The math waveform is specified by x, which can be 1 through 8.

Record lengths can be 20, 50, 100, 250, 500, 1000, 2000, and 4000 samples. It results from normalizing the sources of a math waveform.

Group

Horizontal

Related Commands

HORizontal:MATH<x>:MAIn:SCALE?,
HORizontal:MATH<x>:MAIn:RESolution

Syntax

HORizontal:MATH<x>:MAIn:RECORDLength?

Example

HORizontal:MATH4:MAIn:RECORDLength?

This query might return :HORIZONTAL:MATH4:MAIN:RECORDLENGTH 1000, indicating that the record length for the Main timebase is set to 1000 samples for the Math 4 waveform.

HORizontal:MATH<x>:MAIn:REFPoint?

This query only command returns the horizontal reference point of the specified math waveform using the Main timebase. The math waveform is specified by x, which can be 1 through 8. The horizontal reference point is the horizontal position around which the HORizontal:MAIn:SCAlE command contracts or expands the waveform, which affects the acquired and observable horizontal window of data. The horizontal reference position is set as a fraction of the record; 0.5 (50% of the record) is the default.

Group

Horizontal

Related Commands

HORizontal:MATH<x>:MAIn:SCAlE

Example

```
HORizontal:MATH3:MAIn:REFPoint?
```

This query might return `:HORIZONTAL:MATH3:MAIN:REFPOINT .500000000000`, indicating that the horizontal reference point for the Math 3 waveform using the Main timebase is set to 0.5 (50%).

HORizontal:MATH<x>:MAIn:RESolution?

This query only command returns the current resolution per sample of the Main timebase for the specified math waveform. The math waveform is specified by x, which can be 1 through 8. Resolution is displayed in horizontal units, typically time.

Group

Horizontal

Related Commands

HORizontal:MATH<x>:MAIn:SCAlE?,
HORizontal:MATH<x>:MAIn:RECORDLength?,

Syntax

```
HORizontal:MATH<x>:MAIn:RESolution?
```

Example

```
HORizontal:MATH2:MAIn:RESolution?
```

This query might return `:HORIZONTAL:MATH1:MAIN:RESOLUTION 1.000000000000E-009`, indicating that the Main timebase resolution is at 1 ns for the Math2 waveform.

HORizontal:MATH<x>:MAIn:SCAlE?

This query only command returns the scale (time per division) of the Main timebase for the specified math waveform. The math waveform is specified by x, which can be 1 through 8.

Group

Horizontal

Related Commands

HORizontal:MATH<x>:MAIn:RECOrdlength?,
HORizontal:MATH<x>:MAIn:RESolution?

Syntax

HORizontal:MATH<x>:MAIn:SCALE?

Example

HORizontal:MATH4:MAIn:SCALE?

This query might return :HORIZONTAL:MATH1:MAIN:SCALE
1.000000000000E-009, indicating that the Main timebase for the
Math4 waveform is set to 1 ns per division.

HORizontal:MATH<x>:MAIn:TOFPoint?

This query only command returns the time of first point of the Main timebase record, which is the time interval between the trigger point and the first point in the record, for the specified math waveform. The math waveform is specified by x, which can be 1 through 8.

Group

Horizontal

Related Commands

HORizontal:MATH<x>:MAIN:POSition?,
HORizontal:MATH<x>:MAIn:REFPoint?,
HORizontal:MATH<x>:MAIn:SCALE?

Syntax

HORizontal:MATH<x>:MAIn:TOFPoint?

Example

HORizontal:MATH3:MAIn:TOFPoint?

This query might return :HORIZONTAL:MATH3:MAIN:TOFPOINT
1.000000000000E-12, indicating that the time of first point for the
Main timebase record for the Math3 waveform is 100 ps.

HORizontal:MATH<x>:MAIn:TOLPoint?

This query only command returns the time of last point of the Main timebase record, which is the time interval between the trigger point and the last point in the record, for the specified math waveform. The math waveform is specified by x, which can be 1 through 8.

Group

Horizontal

Related Commands

HORizontal:MATH<x>:MAIN:POSition?,
HORizontal:MATH<x>:MAIn:REFPoint?,
HORizontal:MATH<x>:MAIn:SCALE?

Syntax

HORizontal:MATH<x>:MAIn:TOLPoint?

Example

HORizontal:MATH3:MAIn:TOLPoint?

This query might return :HORIZONTAL:MATH3:MAIN:TOLPOINT
36.0000000000E-009, indicating that the time of last point for the
Main timebase record for the Math3 waveform is 36 ns.

HORizontal:REF<x>:MAG<x>:POSition?

This query only command returns the horizontal position of the specified
Mag timebase for the specified Reference waveform. The Reference
waveform is specified by x, which can be 1 through 8; the Mag timebase
is specified by x, which can be 1 or 2.

Group

Horizontal

Related Commands

HORizontal:REF<x>:MAG<x>:TOFPoint?,
HORizontal:REF<x>:MAG<x>:TOLPoint?

Syntax

HORizontal:REF<x>:MAG<x>:POSition?

Example

HORizontal:REF1:MAG2:POSition?

This query might return
:HORIZONTAL:REF1:MAGNIFY2:POSITION
19.0000000000E-009, indicating that the horizontal position for
the Ref 1 waveform using the MAG2 timebase is the minimum time of
19 ns.

HORizontal:REF<x>:MAG<x>:RECORDLength?

This query only command returns the record length of the Reference
waveform specified by x, which can be 1 through 8, using the specified
Mag timebase (1 or 2). The value of the record length can be 20, 50, 100,
250, 500, 1000, 2000, and 4000 samples.

Group

Horizontal

Related Commands

HORizontal:REF<x>:MAG<x>:SCALE?,
HORizontal:REF<x>:MAG<x>:RESolution?

Syntax

`HORizontal:REF<x>:MAG<x>:RECORDLength?`

Example

`HORizontal:REF5:MAG2:RECORDLength?`

This query might return

`:HORIZONTAL:REF5:MAG2:RECORDLENGTH 1000`, indicating that the record length of the Ref 5 waveform using the Mag 2 timebase is 1000 samples.

HORizontal:REF<x>:MAG<x>:RESolution?

This query only command returns the current resolution per sample of the Reference waveform. The Reference waveform is specified by *x*, which can be 1 through 8; the Mag timebase is specified by *x*, which can be 1 or 2. Resolution is displayed in horizontal units, typically time.

Group

Horizontal

Related Commands

`HORizontal:REF<x>:MAG<x>:SCALE?`,
`HORizontal:REF<x>:MAG<x>:RECORDLength?`

Syntax

`HORizontal:REF<x>:MAG<x>:RESolution?`

Example

`HORizontal:REF1:MAG1:RESolution?`

This query might return

`:HORIZONTAL:REF1:MAGNIFY1:RESOLUTION
12.500000000000E-012`, indicating that the resolution of the Ref 1 waveform using the Mag1 timebase is 12.5 ps.

HORizontal:REF<x>:MAG<x>:SCALE?

This query only command returns the scale (time per division) of the specified Reference waveform using the specified Mag timebase. The Reference waveform is specified by *x*, which can be 1 through 8; the Mag timebase is specified by *x*, which can be 1 or 2.

Group

Horizontal

Related Commands

`HORizontal:REF<x>:MAG<x>:RECORDLength?`,
`HORizontal:REF<x>:MAG<x>:RESolution?`

Syntax

`HORizontal:REF<x>:MAG<x>:SCALE?`

Example

`HORIZONTAL:REF3:MAG2:SCALE?`

This query might return `:HORIZONTAL:REF3:MAGNIFY2:SCALE 1.00000000000E-012`, indicating that the Mag2 timebase is 100 ps per division for the Ref 3 waveform.

HORizontal:REF<x>:MAG<x>:TOFPoint?

This query only command returns time of first point of the specified Reference waveform using the specified Mag timebase. The Reference waveform is specified by x, which can be 1 through 8; the Mag timebase is specified by x, which can be 1 or 2. The time of first point is the time interval between the trigger point and the first point in the specified Mag timebase record (waveform).

Group

Horizontal

Related Commands

HORizontal:REF<x>:MAG<x>:POSition?,
HORizontal:REF<x>:MAG<x>:SCAle?

Syntax

HORizontal:REF<x>:MAG<x>:TOFPoint?

Example

HORizontal:REF1:MAG1:TOFPoint?

This query might return

`:HORIZONTAL:REF1:MAGNIFY1:TOFPOINT`

`50.0000000000E-009`, indicating that the time interval between the trigger point and the first point in the Ref 1 waveform record using the Mag1 timebase is 50 ns.

HORizontal:REF<x>:MAG<x>:TOLPoint?

This query only command returns time of last point of the specified Reference waveform using the specified Mag timebase. The Reference waveform is specified by x, which can be 1 through 8; the Mag timebase is specified by x, which can be 1 or 2. The time of last point is the time interval between the trigger point and the last point in the specified Mag timebase record (waveform).

Group

Horizontal

Related Commands

HORizontal:REF<x>:MAG<x>:POSition?,
HORizontal:REF<x>:MAG<x>:SCAle?

Syntax

HORizontal:REF<x>:MAG<x>:TOLPoint?

Example

HORizontal:REF1:MAG1:TOLPoint?

This query might return
:HORIZONTAL:REF1:MAGNIFY1:TOLPOINT
500.00000000000E-12, indicating that the time of last point of the
Ref 1 waveform record using the Mag 1 timebase is 500 ps.

HORizontal:REF<x>:MAIn:POSition?

This query only command returns the horizontal position of the specified reference waveform using the Main timebase. The reference waveform is specified by x, which can be 1 through 8.

Group

Horizontal

Related Commands

HORizontal:REF<x>:MAIn:REFPoint?,
HORizontal:REF<x>:MAIn:TOFPoint?,
HORizontal:REF<x>:MAIn:TOLPoint?

Syntax

HORizontal:REF<x>MAIN:POSition?

Example

HORizontal:REF5:MAIN:POSition?

This query might return :HORIZONTAL:REF5:MAIN:POSITION
51.36300000000E-009, indicating that the horizontal position of the
Reference 5 waveform using the Main timebase is 51.36 ns.

HORizontal:REF<x>:MAIn:RECORDLength?

This query only command returns the record length of the specified reference waveform using the Main timebase. The reference waveform is specified by x, which can be 1 through 8.

Group

Horizontal

Related Commands

HORizontal:REF<x>:MAIn:RESolution?,
HORizontal:REF<x>:MAIn:SCALE?

Syntax

HORizontal:REF<x>:MAIn:RECORDLength?

Example

HORizontal:REF7:MAIn:RECORDLength?

This query might return
:HORIZONTAL:REF7:MAIN:RECORDLENGTH 1000, indicating
that the record length of the Reference 7 waveform using the Main
timebase is 1000 samples.

HORizontal:REF<x>:MAIn:REFPoint?

This query only command returns the horizontal reference point of the specified reference waveform using the Main timebase. The reference waveform is specified by x, which can be 1 through 8.

Group

Horizontal

Related Commands

HORizontal:REF<x>:MAIn:SCALE?

Syntax

HORizontal:REF<x>:MAIn:REFPoint?

Example

HORizontal:REF1:MAIn:REFPoint?

This query might return :HORIZONTAL:REF1:MAIN:REFPOINT 5.000000000000E-001, indicating that the horizontal reference point of Reference 1 waveform using the Main timebase is set to 0.5 (50%), which is the default.

HORizontal:REF<x>:MAIn:RESolution?

This query only command returns the current resolution per sample of the specified reference waveform using the Main timebase. The reference waveform is specified by x, which can be 1 through 8. The resolution value is the same as the value displayed in the Resolution field in the Timebase section of the Horizontal Setup dialog box. The resolution is determined by the scale and record length values of the reference waveform. Resolution is displayed in horizontal units, typically time.

Group

Horizontal

Related Commands

HORizontal:REF<x>:MAIn:SCALE?,
HORizontal:REF<x>:MAIn:RECORDLength?

Syntax

HORizontal:REF<x>:MAIn:RESolution?

Example

HORizontal:REF7:MAIn:RESolution?

This query might return :HORIZONTAL:REF1:MAIN:RESOLUTION 10.000000000000E-012, indicating that the Reference 1 waveform resolution using the Main timebase is 10 ps.

HORizontal:REF<x>:MAIn:SCALE?

This query only command returns the scale (time per division) of the Main timebase for the specified reference waveform. The reference waveform is specified by x, which can be 1 through 8.

The horizontal scale that is returned with this command is unique to the specified reference waveform. The horizontal scale, together with the record length value, determines the sample interval.

Group

Horizontal

Related Commands

HORizontal:REF<x>MAIn:RECOrdlength?,
HORizontal:REF<x>:MAIn:RESolution?

Syntax

HORizontal:REF<x>:MAIn:SCAle?

Example

HORizontal:REF3:MAIn:SCAle?

This query might return :HORIZONTAL:REF3:MAIN:SCALE
2.00000000000E-009, indicating that the Main timebase is 2 ns per
division for the Reference 3 waveform.

HORizontal:REF<x>:MAIn:TOFPoint?

This query only command returns time of first point of the specified reference waveform record using the Main timebase. The time of first point is the time interval between the trigger point and the first point in the specified Reference Main timebase record.

Group

Horizontal

Related Commands

HORizontal:REF<x>MAIN:POSition?,
HORizontal:REF<x>:MAIn:REFPoint?,
HORizontal:REF<x>:MAIn:SCAle?

Syntax

HORizontal:REF<x>:MAIn:TOFPoint?

Example

HORizontal:REF1:MAIn:TOFPoint?

This query might return :HORIZONTAL:REF1:MAIN:TOFPOINT
41.36300000000E-009, indicating that the time interval between
the trigger point and the first point in the record for the Reference 1 Main
timebase record is 41.36 ns.

HORizontal:REF<x>:MAIn:TOLPoint?

This query only command returns time of last point of the specified reference record (waveform) using the Main timebase. The time of last point is the time interval between the trigger point and the last point in the specified Reference Main timebase record.

Group

Horizontal

Related Commands

HORizontal:REF<x>MAIN:POSition?,
HORizontal:REF<x>:MAin:REFPoint?,
HORizontal:REF<x>:MAIn:SCALE?

Syntax

HORizontal:REF<x>:MAin:TOLPoint?

Example

HORizontal:REF3:MAin:TOLPoint?

This query might return :HORIZONTAL:REF3:MAIN:TOLPOINT
51.300000000000E-009, indicating that the time interval between
the trigger point and the last point in the Reference 3 Main timebase
record is 51.3 ns.

HORizontal:TBMode

This command sets or queries the timebase mode. Sending this command is equivalent to making a selection in the Mode control in the All Timebases section of the Horizontal Setup dialog box.

Group

Horizontal

Syntax 1

HORizontal:TBMode {SHORTTerm|LOCKExt|LOCKInt}

Syntax 2

HORizontal:TBMode?

Arguments

- SHORTTerm
This argument enables the horizontal timebase mode, which gives the best short-term jitter.
- LOCKExt
This argument enables the Lock to Ext. 10 MHz mode, which locks the timebase to an external 10 MHz reference signal.
- LOCKInt
This argument enables the Lock to Int. 10 MHz mode, which locks the timebase to the internal 10 MHz reference signal. This mode yields exceptional long-term horizontal stability.

Example 1

HORizontal:TBMode LOCKInt

This command locks the timebase to the internal 10 MHz reference signal.

Example 2

```
HORizontal:TBMode?
```

This query might return `:HORIZONTAL:TBMODE LOCKEXT`, indicating that the timebase is locked to an external 10 MHz reference signal.

HORizontal:UNIts

This command sets or queries the horizontal units used for all timebases. The available units are seconds, bits, meters, feet, and inches. This is equivalent to selecting Seconds Bits, or Distance for Units in the All Timebases section of the Horizontal Setup dialog box. When selecting Distance for horizontal units, further options are meters, feet and inches.

Group

Horizontal

Related Commands

```
HORizontal:DIStance:DIElectric HORizontal:DIStance:PVELocity
```

Syntax 1

```
HORizontal:UNIts {S|BITS|FT|IN|M}
```

Syntax 2

```
HORizontal:UNIts?
```

Arguments

- S
This argument sets the horizontal units for all timebases to seconds.
- BITS
This argument sets the horizontal units for all timebases to bits.
- FT
This argument sets the horizontal units for all timebases to feet.
- IN
This argument sets the horizontal units for all timebases to inches.
- M
This argument sets the horizontal units for all timebases to meters.

Example 1

```
HORizontal:UNIts S
```

This command sets the horizontal units for all timebases to seconds.

Example 2

```
HORizontal:UNIts?
```

This query might return `:HORIZONTAL:UNITS BITS`, indicating that horizontal units for all timebases is set to bits.

HORizontal?

This query only command returns all settings for the horizontal commands.

Group

Horizontal

Syntax

HORizontal?

Example

HORizontal?

This command might return the following string (partial):

```
:HORIZONTAL:TBMODE LOCKINT;UNITS S;  
:BITS:STANDARD OC192;  
BITRATE 9.953280000000E+009;  
:HORIZONTAL:EXT10MHZREF:FREQ 10.0000000000E+006;  
:HORIZONTAL:MAIN:SCALE 5.0000000000E-009;  
POSITION 811630000000.009;  
RESOLUTION 12.5000000000E-012;  
RECORDLENGTH 4000;REFPOINT 1.0000000000;  
TOLPOINT 81.1630000000E-009;  
TOFPOINT 31.1630000000E-009;  
:HORIZONTAL:MAGNIFY1:SCALE 2.0000000000E-009;  
POSITION 51.1630000000E-009;  
RESOLUTION 10.0000000000E-012;  
RECORDLENGTH 2000;REFPOINT 1.0000000000;  
VIEW 1;TOLPOINT 51.1630000000E-009;  
TOFPOINT 31.1630000000E-009;  
:HORIZONTAL:MAGNIFY2:SCALE 3.3000000000E-011;  
POSITION 31.2130000000E-009;  
RESOLUTION 220.0000000000E-015;  
RECORDLENGTH 1000;REFPOINT 150.0000000000E-003;  
VIEW 0;TOLPOINT 31.4930000000E-009;  
TOFPOINT 31.1630000000E-009;...
```

ID?

This is a query only command that returns identifying information about the instrument and its firmware.

Group

Status and Error

Related Commands

*IDN?

Syntax

ID?

Returns

The instrument id in the following format:

```
TEK/<model number>,CF:92.1CT,FV:<firmware version  
number>
```

LOCK

Example

ID?

This query might return ID

TEK/TDS8000,CF:91.1CT,FV:1.0.444.

This command sets and queries the lock state of the touchscreen and the front-panel controls. There is no front-panel equivalent.

Group

Miscellaneous

Related Commands

UNLock

Syntax 1

LOCK {ALL|NONE|TOUCH|FPAnel}

Syntax 2

LOCK?

Arguments

- **ALL**
Disables all front-panel controls and the touchscreen.
- **NONE**
Enables all front-panel controls and the touchscreen. This is equivalent to the UNLock ALL command.
Note: If the instrument is in the Remote With Lockout State (RWLS), the LOCK NONE command has no effect. For more information, see ANSI/IEEE Std. 488.1-1987 Standard Digital Interface for Programmable Instrumentation, section 2.8.3 on RL State Descriptions.
- **TOUCH**
Disables the touchscreen.
- **FPAnel**
Disables the front-panel controls.

Example 1

LOCK ALL

Locks the front-panel controls and the touchscreen.

Example 2

LOCK?

This query returns :LOCK NONE when the front-panel controls and touchscreen are enabled by this command.

MASK:AUTOSet:MODE

This command sets or queries whether or not a mask autoset will automatically be done after a standard mask is selected. This is equivalent to selecting Automatic or Manual in the Autoset section of the Mask Setup dialog box.

Group

Mask

Syntax 1

```
MASK:AUTOSet:MODE {AUTO|MANual}
```

Syntax 2

```
MASK:AUTOSet:MODE?
```

Arguments

- **AUTO**
Sets the instrument to automatically run the mask autoset when a standard mask (or a user-defined mask that is derived from a standard mask) is selected from the Comm Standard section of the Mask Setup dialog box. Autoset will not run continuously; it will run once when a standard is selected.
- **MANual**
With this argument, the mask autoset algorithm for a standard mask runs only if the user presses the AUTOSET button or sends the AUTOSet EXECute command. If a standard mask (or a user-defined mask that is derived from a standard mask) is not currently selected, the mask autoset algorithm will not run, and the normal autoset will run when the user presses the AUTOSET button. Manual is the default value.

Example 1

```
MASK:AUTOset:MODE AUTO
```

Sets the instrument to automatically run autoset when a standard mask is selected from the Comm Standard section of the Mask Setup dialog box.

Example 2

```
MASK:AUTOSET:MODE?
```

This query might return :MASK:AUTOSET:MODE AUTO, indicating that mask autoset will run automatically when the user selects a standard mask from the front panel.

MASK:COLOr

This command sets or queries the color of the mask. (The command is the same as the DISplay:COLor:MASK command.) This is equivalent to setting Color in the Options section of the Mask Setup dialog box. The available colors are listed in the following table.

Commands that Generate an OPC Message	
Operation	Command
Automatic instrument adjustment	AUTOSet EXECute
Internal self compensation	COMPensate:ALL COMPensate:CH<x> COMPensate:DARKLev:CH<x> COMPensate:MAInframe COMPensate:OPTGAIN:CH<x>
Conditional	ACQuire:STATE ON or ACQuire:STATE RUN (when ACQuire:STOPAfter is set to CONDition)
Hardcopy output	HARDCopy START

Group

MASK

Related Commands

DISplay:COLor:MASK

Syntax 1

MASK:COLOr <NR1>

Syntax 2

MASK:COLOr?

Argument

NR1

NR1 is an integer in the range of 0 through 15 representing a color as defined in the above table.

Example 1

MASK:COLOr 4

This command sets the color of the mask to fuchsia.

Example 2

MASK:COLOr?

This query might return :MASK:COLOR 10, indicating that the color of the mask is green.

MASK:COUNT

This command clears the counts for the masks, clears the data source, and restarts the counting. This is equivalent to clicking Clear in the Mask Counts section of the Mask Setup dialog box. The query form of this command returns all the values for the mask count parameters.

Group

Mask

Syntax 1

MASK:COUNT {RESET}

Syntax 2

`MASK:COUNT?`

Example 1

`MASK:COUNT RESET`

This command clears the counts for the masks, clears the data source, and restarts the counting.

Example 2

`MASK:COUNT?`

This query might return `:MASK:COUNT:STATE 1;TOTAL 487641;WAVEFORMS 2887;SAMPLES 1443500.`

MASK:COUNT:SAMPLES?

This query only command returns the total number of sample points used in the count of the total number of mask hits (returned by the `MASK:COUNT:TOTAL?` query).

Group

Mask

Syntax

`MASK:COUNT:SAMPLES?`

Example

`MASK:COUNT:SAMPLES?`

This query might return `:MASK:COUNT:SAMPLES 500`, indicating that the count of mask hits is based on 500 samples.

MASK:COUNT:STATE

This command sets or queries whether or not mask counting is being done. Sending this command is equivalent to checking or clearing the Enable Mask Counts check box in the Source section of the Mask Setup dialog box.

Group

Mask

Syntax 1

`MASK:COUNT:STATE {ON|OFF|<NR1>}`

Syntax 2

`MASK:COUNT:STATE?`

Arguments

- `OFF`
This argument turns off mask counting. This is the default state.
- `ON`
This argument turns on mask counting.

- NR1

0 turns off mask counting; any other integer turns on mask counting.

Example 1

`MASK:COUNT:STATE ON`

This command turns on mask counting.

Example 2

`MASK:COUNT:STATE?`

This command might return `:MASK:COUNT:STATE 0`, indicating that mask counting is turned off.

NOTE: A query always returns a 0 or 1.

MASK:COUNT:TOTAL?

Description

This query only command returns the sum of all the hits in all the defined masks. If masks overlap (no standard masks overlap) and a hit occurs in the overlap region, the total hits will count that hit multiple times. The query returns the current value, which may be displayed in the Mask readout as Total.

Group

Mask

Syntax

`MASK:COUNT:TOTAL?`

Returns

NR1

Example

`MASK:COUNT:TOTAL?`

This query might return: `MASK:COUNT:TOTAL 20057`, indicating that the total hits in all masks is 20,057.

MASK:COUNT:WAVEforms?

Description

This query only command returns the number of waveforms that have contributed to mask counting. This value may be displayed in the Mask readout as Waveforms.

Group

Mask

Syntax

`MASK:COUNT:WAVEforms?`

Returns

NR1

Example

`MASK:COUNT:WAVEforms`

This query might return: `MASK:COUNT:WAVEFORMS 6568`

MASK:DISplay

This command sets or queries whether or not defined masks are displayed on the screen. This is useful for temporarily turning off user-defined masks without deleting them. This is equivalent to checking or clearing the Display Mask control in the Options section of the Mask Setup dialog box.

Group

Mask

Syntax 1

`MASK:DISplay {OFF|ON|<NR1>}`

Syntax 2

`MASK:DISplay?`

Arguments

- **OFF**
Removes the masks from the display; this does not turn mask counting off. This is the default value.
- **ON**
This argument displays the masks. Turning mask counting on turns this on. Selecting any standard mask turns this on.
`MASK:MASK<x>:POINTSPCNT` or `MASK:MASK<x>:POINTS` turns this on.
- **NR1**
0 turns off the mask display; any other integer turns on the mask display.

Example 1

`MASK:DISPLAY ON`

This command sets the display to show the defined masks.

Example 2

`MASK:DISPLAY?`

This command might return 1, indicating that the display shows masks.

NOTE: A query always returns a 0 or 1.

MASK:MARgin:PERCent

This command sets or queries the mask-margin percentage. (This is equivalent to setting a value in the Margin control in the Mask Margins section of the Mask Setup dialog box.) If the margin percentage would cause the masks to either go off screen or cross one another, the margin is not allowed, and the last valid margin is restored. If you set a positive

mask margin percentage, the polygon expands and the mask test will be more difficult to pass due to the expanded test area. If you set a negative mask margin percentage, the polygon shrinks and the mask test will be easier to pass due to the smaller area.

Group

Mask

Syntax 1

```
MASK:MARgin:PERCent <NR3>
```

Syntax 2

```
MASK:MARgin:PERCent?
```

Argument

NR3

This value is -90.0 to +100.0. The default is 5.

Example 1

```
MASK:MARgin:PERCent 25
```

Sets the mask margin percentage to 25.

Example 2

```
MASK:MARgin:PERCent?
```

This query might return :MASK:MARGIN:PERCENT

1.000000000000E+001, indicating that the mask margin is set to 10%.

MASK:MARgin:STATE

This command sets or queries the state of the mask margins. This is equivalent to checking or clearing the On check box in the Mask Margins section of the Mask Setup dialog box.

Group

Mask

Syntax 1

```
MASK:MARgin:STATE {ON|OFF|<NR1>}
```

Syntax 2

```
MASK:MARgin:STATE?
```

Arguments

- OFF
Turns off mask margins. The default is OFF. The currently displayed margined mask is erased and the original mask is displayed.
- ON
Turns on mask margins.
- NR1
0 turns off mask margins; any other integer turns on the selected

mask margins.

Example 1

```
MASK:MARGin:STATE ON
```

This command turns on mask margins.

Example 2

```
MASK:MARGIN:STATE?
```

This query might return :MASK:MARGIN:STATE 1, indicating that mask margins are on.

NOTE: A query always returns a 0 or 1.

MASK:MASK<x>

This command deletes all points in the mask specified by x, which can be 1 through 8. The query form of this command returns all the parameters for the specified mask.

Group

Mask

Syntax 1

```
MASK:MASK<x> {DELEte}
```

Syntax 2

```
MASK:MASK<x>?
```

Argument

DELEte

Deletes all points in the specified mask.

Example 1

```
MASK:MASK3 DELETE
```

Deletes the points in Mask 3.

Example 2

```
MASK:MASK2?
```

```
This query might return :MASK:MASK2:COUNT 973938;  
NR_PT 6;POINTS 2.41362680953E-008,1.25313281387E-  
005,  
2.80024003985E-008,-1.59147870727E-003,  
3.37463674782E-008,-1.59147870727E-003,  
3.76125015578E-008,1.25313281387E-005,  
3.37463674782E-008,1.61654129624E-003,  
2.80024003985E-008,1.61654129624E-003;  
POINTSPCNT 25.4000,49.7500,39.4000,65.7500,  
60.2000,65.7500,74.2000,49.7500,60.2000,  
33.7500,39.4000,33.7500.
```

MASK:MASK<x>:COUNT?

This query only command returns the number of hits in the specified mask. The mask is specified by <x>, which can be 1 through 8. The count will be zero unless the MASK:COUNT:STATE is ON (or was ON).

Group

Mask

Related Commands

MASK:COUNT:STATE

Syntax

MASK:MASK<x>:COUNT?

Returns

NR1

This is the number of hits in the specified mask.

Example

MASK:MASK3:COUNT?

This query might return :MASK:MASK3:COUNT 1478, indicating that the number of hits in Mask 3 is 1478.

MASK:MASK<x>:NR_PT?

This query only command returns the number of points (vertices) in the specified mask. The mask is specified by <x>, which can be 1 through 8. One use of this query is to see how many pairs a MASK:MASK<x>:POINTSPcnt or MASK:MASK<x>:POInts command will return.

Group

Mask

Related Commands

MASK:MASK<x>:POInts, MASK:MASK<x>:POINTSPcnt

Syntax

MASK:MASK<x>:NR_PT?

Returns

<NR1>

This is the number of points in the specified mask.

Example

MASK:MASK3:NR_PT?

This query might return :MASK:MASK3:NR_PT 6, indicating that Mask 3 has 6 points.

MASK:MASK<x>:POInts

This command sets or queries the points (vertices) in the specified mask in waveform coordinates. The mask is specified by <x>, which can be 1 through 8. When you send this command, any currently existing points in the mask are deleted. Each point or vertex is an xy coordinate that represents a horizontal/vertical pair in source waveform (user) units. The order of the pairs has no effect on the mask created.

If the vertical or horizontal scale or position changes after this command is executed, a query will return different values for the vertices. This is because the mask polygons remain stationary on the display, but the relationship of the internal coordinate system to the absolute user values changes.

Note: If the specified mask is undefined, a query will return 0, 0.

Group

Mask

Syntax 1

```
MASK:MASK<x>POInts <NR3>, <NR3>, <NR3>, <NR3>, [... , ...]
```

Syntax 2

```
MASK:MASK<x>POInts?
```

Argument

NR3

This is the pair of xy coordinates for a point (vertex) in the mask. Each mask polygon can have a maximum of 50 points or vertices. You must specify more than two pair of points, otherwise the mask is marked as undefined, and the points are ignored. The default is no points in the mask.

Example 1

```
MASK:MASK7:POInts -2.3e-9,44e-3,-2.5e-9,47e-3,  
1.2e-9,40e-3
```

This command defines the points in mask 7.

Example 2

```
MASK:MASK3:POInts?
```

This query might return :MASK:MASK3:POINTS
1.97664729029E-008,-5.00000000000E-001,
2.13889173040E-008,-5.00000000000E-001,
2.13843094343E-008,-3.74686717987E-001,
1.97710825489E-008,-3.74686717987E-001,
indicating the points in Mask 3.

MASK:MASK<x>:POINTSPcnt

This command sets or queries the points (vertices) in the specified mask in percentage coordinates. The mask is specified by <x>, which can be 1 through 8. Any currently existing points in the mask are deleted. The upper leftmost point is 0,0, and the lower rightmost point is 100,100.

Each mask polygon can have a maximum of 50 points or vertices. If more than 50 points are specified, an error is generated and the extra points are ignored. If any point is outside of 0...100, an error is generated, and the point is clipped to the nearest boundary. The order of the pairs has no effect on the mask created.

Note: If the specified mask is undefined, a query will return 0, 0.

Group

Mask

Syntax 1

```
MASK:MASK<x>:POINTSPcnt <NR3>, <NR3>[ , <NR3>, <NR3>, ...]
```

Syntax 2

```
MASK:MASK<x>:POINTSPcnt?
```

Argument

NR3

This is the pair of xy coordinates for a point (vertex) in the mask. You must specify more than two pair of points, otherwise the mask is marked as undefined, and the points are ignored. Resolution of the NR3 value is to the nearest pixel. 500 pixels horizontally implies 0.2% resolution; 400 pixels vertically implies 0.25% resolution. The default is no points in the mask.

Example 1

```
MASK:MASK7:POINTSPcnt 20.4,10.5,90,10.5,50,80
```

Defines the points in Mask 7.

Example 2

```
MASK:MASK7:POINTSPcnt?
```

This query might return :MASK:MASK7:POINTSPCNT
20.4000,10.5000,90.000,10.500,50.000,80.000 as the
percentage coordinates for Mask 7.

MASK:SOURce

This command sets or queries which source will be compared against the mask(s) when counting is turned on. This command can optionally set the timebase of the source. This is equivalent to selecting a waveform (and timebase) in the Source section of the Mask Setup dialog box. If you do not specify the timebase, the default is Main.

Group

Mask

Syntax 1

```
MASK:SOURce {CH(x)|MATH(X)|REF(X)}  
[ , {MAIn|MAG1|MAG2}]
```

Syntax 2

```
MASK:SOURce?
```

Arguments

- CH<x>
This argument selects a channel waveform to be compared against the specified mask. The range for x is 1 through 8.
- MATH<x>
This argument selects a math waveform to be compared against the specified mask. The range for x is 1 through 8.
- REF<x>
This argument selects a reference waveform to be compared against the specified mask. The range for x is 1 through 8.
- MAIN
This optional argument selects Main as the timebase for the specified waveform to be compared against the mask. This is the default timebase.
- MAG1
This optional argument selects MAG1 as the timebase for the specified waveform to be compared against the mask.
- MAG2
This optional argument selects MAG2 as the timebase for the specified waveform to be compared against the mask.

Example 1

```
MASK:SOURCE CH1
```

Enables CH1 to be compared against the mask. Since a timebase is not specified, the default, Main, is used.

Example 2

```
MASK:SOURCE?
```

This query might return `:MASK:SOURCE CH1,MAIN`, indicating that the Channel 1 waveform will be compared against the mask using the Main timebase.

MASK:STANDARD

This command selects a set of predefined mask polygons (hereafter referred to as a "mask") to be used for mask testing in accordance with the communications standard specified by the command argument. The query form of this command returns the current mask selected. Note the following usage rules:

- Setting the MASK:STANDARD sets the HORIZONTAL:BITS:STANDARD to the same argument, thereby setting the horizontal bit rate to the bit rate associated with the selected standard.
- Do not use the USERMASK to select a user-defined mask, rather use the MASK:MASK<X>:POINTS and/or the MASK:MASK<X>:POINTSPCNT commands to define the mask. This action coerces the MASK:STANDARD and

HORizontal:BITS:STANdard settings to USERMask. (The USERMask setting cannot be selected directly with the MASK:STANdard command, but MASK:STANdard queries will return USERMask when user-defined masks are selected.)

- When you use user-defined masks, you should set the horizontal bit rate explicitly with the HORizontal:BITS:BITRate command.
- You can use the MASK:MASK<X> commands to access the current masks, whether predefined or user defined, and their associated counters.
- If you specify user-defined masks, note that selecting one of the predefined mask standards will overwrite your user-defined masks. If your test is related to one of the predefined mask standards, you might want to first select the related predefined standard, and then only modify the masks and/or bit rate as required.
- Selecting NONE will delete all currently defined masks.
- If MASK:COUNt:STATE is ON, then mask counting starts.

Group

Mask

Syntax 1

```
MASK:STANdard {NONE|OC1|OC3|OC9|OC12|OC18|OC24  
|OC36|OC48|FEC2666|OC192|FEC10664|FEC10709|OC768  
|FEC42657|FC133|FC266|FC531|FC1063|FC2125|FC4250  
|FC133E|FC266E|FC531E|FC1063E|ENET1250|ENET3125  
|ENET9953|ENET10313|INFIniband|USERMask}
```

Syntax 2

```
MASK:STANdard?
```

Arguments

- NONE
Disables the communications standards.
- OC1
Selects the 51.84 Mb/s bit rate, in accordance with the Sonet/SDHOC-1/STM-0 standard.
- OC3
Selects the 155.52 Mb/s bit rate, in accordance with the Sonet/SDHOC-3/STM-1 standard.
- OC9
Selects the 466.56 Mb/s bit rate, in accordance with the Sonet/SDHOC-9/STM-3 standard.
- OC12
Selects the 622.08 Mb/s bit rate, in accordance with the Sonet/SDHOC-12/STM-4 standard.
- OC18

Selects the 933.12 Mb/s bit rate, in accordance with the Sonet/SDHOC-18/STM-6 standard.

- OC24
Selects the 1.24416 Gb/s bit rate, in accordance with the Sonet/SDHOC-24/STM-8 standard.
- OC36
Selects the 1.86624 Gb/s bit rate, in accordance with the Sonet/SDHOC-36/STM-12 standard.
- OC48
Selects the 2.488.32 Gb/s bit rate, in accordance with the Sonet/SDHOC-48/STM-16 standard.
- FEC2666
Selects the 2.6660571 Gb/s bit rate, in accordance with the ITU-T G.975 Recommendation
- OC192
Selects the 9.95328 Gb/s bit rate, in accordance with the Sonet/SDHOC192/STM-64 standard.
- FEC10664
Selects the 10.6642 Gb/s bit rate, in accordance with the ITU-T G.975 Recommendation
- FEC10709
Selects the 10.709225 Gb/s bit rate, in accordance with the ITU-T G.709 Draft Recommendation
- OC768
Selects the 39.8131 Gb/s bit rate, in accordance with the Sonet/SDHOC768/STM-256 standard.
- FEC42657
Selects the 42.6569 Gb/s bit rate, in accordance with the ITU-T G.975 Recommendation
- FC133
Selects the 132.81 Mb/s bit rate, in accordance with the ANSI X3.230-1994 standard.
- FC266
Selects the 265.6 Mb/s bit rate, in accordance with the ANSI X3.230-1994 standard.
- FC531
Selects the 531.2 Mb/s bit rate, in accordance with the ANSI X3.230-1994 standard.
- FC1063
Selects the 1.0625 Gb/s bit rate, in accordance with the ANSI X3.230-1994 standard.

- FC2125
Selects the 2.125 Gb/s bit rate, in accordance with the ANSI Fibre Channel Physical Interface (FC-PI) Rev 11 draft standard.
- FC4250
Selects the 4.250 Gb/s bit rate, in accordance with the ANSI Fibre Channel Physical Interface (FC-PI) Rev 11 draft standard.
- FC133E
Selects the 132.81 Mb/s bit rate, in accordance with the ANSI X3.230-1994 standard.
- FC266E
Selects the 265.6 Mb/s bit rate, in accordance with the ANSI X3.230-1994 standard.
- FC531E
Selects the 531.2 Mb/s bit rate, in accordance with the ANSI X3.230-1994 standard.
- FC1063E
Selects the 10.625 Gb/s bit rate, in accordance with the ANSI X3.230-1994 standard.
- ENET1250
Selects the 1.250 Gb/s bit rate, in accordance with the IEEE 802.3 standard.
- ENET3125
Selects the 3.125 Gb/s bit rate, in accordance with the IEEE P802.ae draft standard.
- ENET9953
Selects the 9.9533 Gb/s bit rate, in accordance with the IEEE P802.ae draft standard.
- ENET10313
Selects the 10.3125 Gb/s bit rate, in accordance with the IEEE P802.ae draft standard.
- INFIniband
Selects the 2.500 Gb/s bit rate, in accordance with the InfiniBand standard.
- USERMask
Sets the bit rate in accordance with a user-defined standard.

Example 1

`MASK:STANdard OC3`

This command selects the OC3 standard Sonet/SDH optical mask with a data rate of 155.52 Mb/s.

Example 2

`MASK:STANdard?`

This query might return `:MASK:STANDARD OC12`, indicating that the Sonet (SDH) OC12/STM-4 optical mask with a data rate of 622.08 Mb/s is selected as the current mask standard.

MASK:WFMDB:STATE

This command sets or queries whether the MASK counting is made on a waveform database. This is equivalent to selecting or clearing the Use Wfm Database check box in the Source section of the Mask Setup dialog box.

Group

MASK

Syntax 1

`MASK:WFMDB:STATE {ON|OFF|NR1}`

Syntax 2

`MASK:WFMDB:STATE?`

Arguments

- ON
This argument enables mask counting on a waveform database.
- OFF
This argument disables mask counting on a waveform database (mask counting is then performed on directly on the acquired waveform).
- NR1
A 0 disables the mask counting on a waveform database; any other value enables mask counting on a waveform database.

Example 1

`MASK:WFMDB:STATE ON`

This command enables mask counting on a waveform database.

Example 2

`MASK:WFMDB:STATE?`

This query might return `:MASK:WFMDB:STATE 0`, indicating that the mask counting on a waveform database is disabled.

NOTE: A query always returns a 0 or 1.

MASK?

This query only command returns the status of all settable mask parameters.

Group

Mask

Syntax

`MASK?`

Example

MASK?

This query might return the following:

```
:MASK:AUTOSET:MODE MANUAL;:MASK:STANDARD OC1;
COLOR 4;COUNT:STATE 1;TOTAL 238201;WAVEFORMS
1066;SAMPLES 0;:MASK:DISPLAY 1;
MARGIN:PERCENT 5.00000000000E+000;STATE 0;
:MASK:MASK1:COUNT 0;NR_PT 4;POINTS
2.11538235817E-008,4.99999988824E-003,
2.12090540685E-008,3.74686717987E-003,
4.05397138081E-008,3.74686717987E-003,
4.05949442950E-008,4.99999988824E-003;
POINTSPCNT 14.6000,0.0000,14.8000,
12.5000,84.8000,12.5000,85.0000,0.0000;
:MASK:MASK2:COUNT 238201;NR_PT 6;
POINTS 2.41362680953E-008,1.25313281387E-005,
2.80024003985E-008,-1.59147870727E-003,
3.37463674782E-008,-1.59147870727E-003,
3.76125015578E-008,1.25313281387E-005,
3.37463674782E-008,1.61654129624E-003,
2.80024003985E-008,1.61654129624E-003;
POINTSPCNT 25.4000,49.7500,39.4000,65.7500,
60.2000,65.7500,74.2000,49.7500,60.2000,33.7500,
39.4000,33.7500;:MASK:MASK3:COUNT 0;
NR_PT 4;POINTS 2.11538235817E-008,
-4.99999988824E-003,4.05949442950E-008,
-4.99999988824E-003,4.05397138081E-008,
-3.74686717987E-003,2.12090540685E-008,
-3.74686717987E-003;POINTSPCNT14.6000,
99.7500,85.0000,99.7500,84.8000,87.2500,
14.8000,87.2500;:MASK:MASK4:COUNT 0;
NR_PT 0;POINTS ;POINTSPCNT ;:MASK:MASK5:COUNT 0;
NR_PT 0;POINTS ;POINTSPCNT ;:MASK:MASK6:COUNT 0;
NR_PT 0;POINTS ;POINTSPCNT ;:MASK:MASK7:COUNT 0;
NR_PT 0;POINTS ;POINTSPCNT ;:MASK:MASK8:COUNT 0;
NR_PT 0;POINTS ;POINTSPCNT ;:MASK:SOURCE CH1,MAIN;
WFMDB:STATE 0
```

MATH<x>:DEFine

This command allows you to define new waveforms using mathematical expressions. Sending this command is equivalent to selecting a math waveform (M1 through M8) and entering a math expression in the Define Math dialog box. The query form of this command returns the math definition for the specified math waveform.

You can specify a math expression from waveforms, measurements and scalar sources, functions, operators, and numerical constants. You can define and display up to eight math waveforms simultaneously.

Math expressions can be simple, such as C1, which specifies that a waveform should show the signal source of Channel 1 with no mathematical computation. Math expressions can also be complex, consisting of 100 plus characters and comprising many sources, functions, and operands. As an example, you can enter the expression $\text{Log}(C1+C2)$, which specifies that the signals from Channels 1 and 2 are to be algebraically added, and the base 10 log of the sum is to be shown as the final math waveform.

For detailed information about constructing mathematical expressions, refer to the 8000 Series User online help for this instrument.

Group

Math

Related Commands

SElect:MATH<x>

Syntax 1

```
MATH<x>:DEFine <QString>
```

Syntax 2

```
MATH<x>:DEFine?
```

Argument

QString

This quoted string argument is the mathematical expression that defines the waveform.

Example 1

```
MATH2:DEFine "C1+C2"
```

Adds the Channel 1 waveform and Channel 2 waveform, and stores the result in Math 2.

Example 2

```
MATH1:DEFine?
```

This query might return :MATH1:DEFINE "C2*R2" as the expression that defines Math 1.

MATH<x>:FILTer:MODE

This command sets or queries the filter mode for the math waveform specified by x, which can be 1 through 8.

Group

Math

Related Commands

MATH<x>:DEFine, MATH<x>:FILTer:RISetime

Syntax 1

```
MATH<x>:FILTer:MODE {CENTERed|SHIFted}
```

Syntax 2

```
MATH<x>:FILTer:MODE?
```

Arguments

- CENTERed

This argument invokes a centered filter mode that is noncausal and uses an average that is centered on each point. This is the default.

- SHIFted

This argument invokes a shifted filter mode that is causal and forms the average for each point based only on preceding points.

Example 1

```
MATH2:FILTeR:MODE CeNTErEd
```

This command sets the filter mode to centered for the specified math waveform.

Example 2

```
MATH5:FILTeR:MODE?
```

This query might return `:MATH5:FILTER:MODE SHIFTED`, indicating that the shifted filter mode is applied to the Math 5 waveform.

MATH<x>:FILTeR:RISeTime

This command sets or queries the risetime (bandwidth) of the math filter function.

Group

Math

Syntax 1

```
MATH<x>:FILTeR:RISeTime <NR3>
```

Related Commands

MATH<x>:DEFine, MATH<x>:FILTeR:MODE

Syntax 2

```
MATH<x>:FILTeR:RISeTime?
```

Argument

NR3

This is the value of the risetime.

Example 1

```
MATH2:FILTeR:RISeTime 1.0E-12
```

This command sets the risetime of the Math 2 risetime filter to 1 ps.

Example 2

```
MATH2:FILTeR:RISeTime?
```

This query might return `:MATH2:FILTER:RISETIME 1.000000000000E-009`, indicating that the risetime of the math filter used for the Math 2 waveform is set to 1 ns.

MATH<x>:NUMavg

This command sets or queries the number of waveforms to average for a math waveform.

Group

Math

Related Commands

MATH<x>:DEFine

Syntax 1

MATH<x>:NUMavg <NR1>

Syntax 2

MATH<x>:NUMavg?

Argument

NR1

This is the number of waveforms to average for a math waveform.

Example 1

MATH4:NUMavg 25

This command sets the number of waveforms to average for the Math 4 waveform to 25.

Example 2

MATH2:NUMavg?

This query might return :MATH2:NUMAVG 15, indicating that the number of waveforms to average for the Math 2 waveform is 15.

MATH<x>:POSition

This command allows you to set or query the vertical position of the specified math waveform. The math waveform is specified by x, which can be 1 through 8. This is equivalent to specifying a math waveform in the Waveform section of the Vertical Setup dialog box and then entering a value for Position in the Setup section.

Groups

Math, Vertical

Syntax 1

MATH<x>:POSition <NR3>

Related Commands

MATH<x>:SCALE

Syntax 2

MATH<x>:POSition?

Argument

NR3

This is the desired position in divisions from the center graticule. The range is ± 1000 divisions.

Example 1

MATH2:POSition 1.3E+00

This command positions the Math 2 waveform 1.3 divisions above the center of the display.

Example 2

MATH1:POSition?

This query might return `:MATH1:POSITION -1.50000000000E+000` as the position setting for the Math 1 waveform, indicating that the waveform is positioned 1.5 divisions below the center of the display.

MATH<x>:POSition

This command allows you to set or query the vertical position of the specified math waveform. The math waveform is specified by *x*, which can be 1 through 8. This is equivalent to specifying a math waveform in the Waveform section of the Vertical Setup dialog box and then entering a value for Position in the Setup section.

Groups

Math, Vertical

Syntax 1

```
MATH<x>:POSition <NR3>
```

Related Commands

MATH<x>:SCALE

Syntax 2

```
MATH<x>:POSition?
```

Argument

NR3

This is the desired position in divisions from the center graticule. The range is ± 1000 divisions.

Example 1

```
MATH2:POSition 1.3E+00
```

This command positions the Math 2 waveform 1.3 divisions above the center of the display.

Example 2

```
MATH1:POSition?
```

This query might return `:MATH1:POSITION -1.50000000000` as the position setting for the Math 1 waveform, indicating that the waveform is positioned 1.5 divisions below the center of the display.

MATH<x>:SCALE

This command allows you to set or query the vertical scale of the math waveform specified by *x*, which can be 1 through 8. This is equivalent to specifying a math waveform in the Waveform section of the Vertical Setup dialog box and then entering a value for Scale in the Setup section.

Each waveform has its own vertical scale parameter. For a signal with constant amplitude, increasing the scale causes the waveform to be displayed smaller. Decreasing the scale causes the waveform to be displayed larger. For math waveforms, this setting controls the display only, graphically scaling these waveforms and having no effect on the acquisition hardware.

Groups

Math, Vertical

Related Commands

MATH<x>:POSition

Syntax 1

MATH<x>:SCAlE <NR3>

Syntax 2

MATH<x>:SCAlE?

Argument

NR3

This is the scale in vertical units per division. The range is 1.0E-30 to 1.0E+30.

Example 1

MATH4:SCAlE 100E-03

This command sets the Math 4 waveform scale to 100 mV per division.

Example 2

MATH1:SCAlE?

This query might return :MATH1:SCALE 1.000000000000E-001 as the scale setting for the Math 1 waveform, indicating that the current volts per division setting of the Math 1 waveform is 100 mV per division.

MATH<x>:SCAlE

This command allows you to set or query the vertical scale of the math waveform specified by x, which can be 1 through 8. This is equivalent to specifying a math waveform in the Waveform section of the Vertical Setup dialog box and then entering a value for Scale in the Setup section.

Each waveform has its own vertical scale parameter. For a signal with constant amplitude, increasing the scale causes the waveform to be displayed smaller. Decreasing the scale causes the waveform to be displayed larger. For math waveforms, this setting controls the display only, graphically scaling these waveforms and having no effect on the acquisition hardware.

Groups

Math, Vertical

Related Commands

MATH<x>:POSition

Syntax 1

MATH<x>:SCAlE <NR3>

Syntax 2

MATH<x>:SCAlE?

Argument

NR3

This is the scale in vertical units per division. The range is 1.0E-30 to 1.0E+30.

Example 1

```
MATH4:SCALE 100E-03
```

This command sets the Math 4 waveform scale to 100 mV per division.

Example 2

```
MATH1:SCALE?
```

This query might return `:MATH1:SCALE 0.100000000000` as the scale setting for the Math 1 waveform, indicating that the current volts per division setting of the Math 1 waveform is 100 mV per division.

MATH<x>:UNITs?

This query only command returns the math units for the specified math waveform. The x argument can be 1 through 8, specifying math waveforms M1 through M8. The instrument will attempt to determine the appropriate units for the result of the math expression that generates the math waveform. The default is UNDEFINED unless one of the following rules can be applied:

- If the resultant waveform is unitless, a "U" is displayed for the unit label.
- Plus (+), Minus (-), Average, Envelope, and Filter functions use the unit label of the source operands for the vertical axis readout and the horizontal axis unit label of the source operands for the horizontal axis readout. If the units for the sources are not the same, then the result is unitless.
- An integration function concatenates the vertical axis unit label and the horizontal axis label of its source operand for the vertical axis readout (for example, Vs) and the horizontal axis unit label of the source operands for the horizontal axis readout.
- A differential function concatenates the vertical axis unit label and the horizontal axis label of its source operand with a slash (/) inserted between labels (for example, V/s) and the horizontal axis unit label of the source operands for the horizontal axis readout.
- The multiply function (*) concatenates the vertical axis unit labels of its source operands for the vertical axis readout (for example, VV) and the horizontal axis unit label of the source operands for the horizontal axis readout.
- The divide function concatenates the unit labels of its source operands with a slash (/) inserted between the labels (for example, V/V) and the horizontal axis unit label of the source operands for the horizontal axis readout.

- The log, ln, sqrt, and e^x function results are unitless.

Group

Math

Syntax

MATH<x>:UNITs?

Example

MATH3:UNITs?

This query might return :MATH3:UNITs "V", indicating that the units for Math 3 waveform are volts.

MATH<x>:WFMLabel

This command sets or queries the label associated with the math waveform specified.

Group

Math

Related Commands

CH<x>:WFMLabel, REF<x>:WFMLabel

Syntax 1

MATH<x>:WFMLabel

Syntax2

MATH<x>:WFMLabel?

Argument

Qstring

This argument sets the label for the math waveform.

Example 1

MATH1:WFMLabel "My MATH1 waveform"

This command sets the label for MATH1 to be "My MATH1 waveform," which is the label displayed with the waveform when it is displayed on screen.

Example 2

MATH1:WFMLabel?

This query might return :MATH1:WFMLABEL "My MATH1 waveform," indicating that the label for the MATH1 waveform is set to "My MATH1 waveform."

MATH<x>?

This is a query only command that returns the settings for the math waveform specified by <x>, which can be 1 through 8.

Group

Math

Syntax

MATH<x>?

Example

MATH3?

This query might return :MATH3:POSITION
1.59400000000+001;
SCALE 1.00000000000-001;DEFINE "C3+C3/C3";UNITS
"V";
FILTER:RISETIME 1.00000000000-009;MODE CENTERED;
MATH3NUMAVG 2.

MEASUREMENT:ALL:VALUE?

This query only command returns all the measurement values.

Group

Measurement

Related Commands

MEASUREMENT:LISTVALUE?,

MEASUREMENT:MEAS<x>:VALUE?

Syntax

MEASUREMENT:ALL:VALUE?

Example

MEASUREMENT:ALL:VALUE?

This query might return :MEASUREMENT:ALL:VALUE
5.18798842266E-004,
1.08967389191E-010,99.10000000000E+36,
1.57041666667E-009,6.367736800021E+008,
99.10000000000E+36,4.11368599818E-001",
99.10000000000E+36 as the listing of the eight possible
measurement values.

Note: The value 99.10000000000E+36 in the returned list of values is the numeric equivalent to NAN (not a number); this value indicates that the measurement slot does not have a valid measurement defined for it.

MEASUREMENT:ANNOTATIONS:STATE

This command sets or queries whether annotations are displayed. This is equivalent to toggling the Annotations check box in the Measurement Setup dialog box. To display gates used in gated measurements, Gates must be enabled with the MEASUREMENT:MEAS<x>:GATING:STATE command.

Group

Measurement

Related Commands

MEASUREMENT:MEAS<x>:GATING:STATE

Syntax 1

MEASUREMENT:ANNOTATIONS:STATE {ON|OFF|NR1}

Syntax 2

MEASUREMENT:ANNOTATIONS:STATE?

Arguments

- ON
Enables the display of annotations.
- OFF
Disables the display of annotations.
- NR1
A 0 disables the display of annotations; any other integer enables the display of annotations.

Example 1

MEASUREMENT:ANNOTATIONS:STATE ON

This command enables the display of annotations.

Example 2

MEASUREMENT:ANNOTATIONS:STATE?

This query might return :MEASUREMENT:ANNOTATIONS:STATE 0, indicating that the display of annotations is disabled.

NOTE: A query always returns a 0 or 1.

MEASUREMENT:LIST

You use this command to establish a list of defined measurements for which you want values returned. The query form of this command returns the list of the defined measurements (for example, MEAS1, MEAS2). You can use the MEASUREMENT:LISTValue? query to get the value for each of the defined measurements in the list. There is no equivalent front-panel or user-interface application control for this feature.

Group

Measurement

Related Commands

MEASUREMENT:LISTValue?

Syntax 1

MEASUREMENT:LIST {<NR1>[, <NR1>]}

Syntax 2:

MEASUREMENT:LIST?

Argument

NR1

This argument is one of the defined measurement slots. You can create a list of up to 8 measurements (1 through 8) that correspond to Meas 1 through Meas 8.

Example 1

```
MEASUrement:LIST 1,4,5
```

This command establishes a list of 3 defined measurements (Meas 1, Meas 4, and Meas 5) for which values can be returned.

Example 2

```
MEASUrement:LIST?
```

This query might return `:MEASUREMENT:LIST 1,2`, indicating that the list consists of two measurements.

MEASUrement:LISTValue?

This query only command returns the values of the measurements in the list created with the MEASUrement:LIST command.

Group

Measurement

Related Commands

MEASUrement:LIST

Syntax

```
MEASUrement:LISTVALue?
```

Example

```
MEASUrement:LISTVALue?
```

This query might return `:MEASUREMENT:LISTVALUE 1.52587894784E-004,2.49499996255E-010`, which are the measurement values for the measurement slots defined as part of the list.

MEASUrement:MEAS<x>:ALL?

This query only command returns all the statistics for the measurement specified by x, which can be 1 through 8. Before you send this command, send the MEASUrement:STATIstics:ENABle ON command to ensure accurate measurement statistics. The following measurement values are returned:

- Maximum (see MEASUrement:MEAS<x>:MAXimum?)
- Minimum (see MEASUrement:MEAS<x>:MINimum?)
- Mean (see MEASUrement:MEAS<x>:MEAN?)
- Standard deviation (see MEASUrement:MEAS<x>:STDdev?)
- Measurement value (see MEASUrement:MEAS<x>:VALue?)

Group

Measurement

Related Commands

MEASUrement:MEAS<x>:MAXimum?,
MEASUrement:MEAS<x>:MINImum?,
MEASUrement:MEAS<x>:MEAN?,
MEASUrement:MEAS<x>:STDdev?,
MEASUrement:MEAS<x>:VALue?,
MEASUrement:STATIstics:ENABle ON

Syntax

MEASUrement:MEAS<x>:ALL?

Returns

NR3

Example

MEASUREMENT:MEAS1:ALL?

This query might return :MEASUREMENT:MEAS1:ALL
2.15759283225E-002, 2.44140631654E-003,
3.23194688283E-003, 2.67703731965E-003,
3.20434579046E-003.

MEASUrement:MEAS<x>:EYEWindow

This command sets or queries the eye aperture value. This value is the percentage of the interval between two eye crossings (centered on the middle of the eye region) within which eye measurements are taken. (See the figure below.) The interval from the first crossing to the second crossing is equivalent to 100%. Sending this command is equivalent to setting a percentage for the Aperture control in the Eye section of the Region tab in the Measurement Setup dialog box. The Eye section is displayed only if you have an eye-pattern or optical measurement defined.

Eye aperture is used for eye measurements, such as Extinction Ratio, Percent, dB, Qfactor, Eye Height and Crossing Percent.

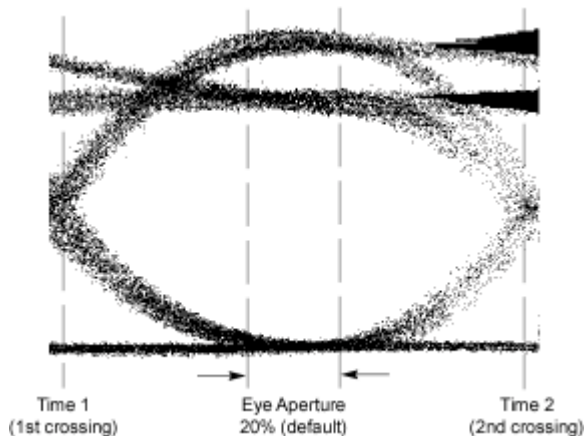

Group

Measurement

Syntax 1

```
MEASUrement:MEAS<x>:EYEWindow <NR2>
```

Syntax 2:

```
MEASUrement:MEAS<x>:EYEWindow?
```

Arguments

NR2

This argument is the percent of interval between two eye crossings centered on the middle of the region. The range is 0 to 100. The default is 20.

Example 1

```
MEASUrement:MEAS1:EYEWindow 25
```

This command sets the eye aperture (window) to 25% for Measurement 1.

Example 2

```
MEASUrement:MEAS1:EYEWindow?
```

This query might return `MEASUREMENT:MEAS1:EYEWINDOW 10`, indicating that the eye aperture is set to 10%. Measurement 1 will be taken within this region.

MEASUrement:MEAS<x>:GATing:STATE

This command sets or queries the gating state for the measurement slot specified by x, which can be 1 through 8. Sending this command is equivalent to toggling the On check box in the Gates section of the Region portion of the Measurement Setup dialog box.

A gate defines a segment of waveform data over which the measurement is performed. You can define the specified measurement using the `MEASUrement:MEAS<x>:TYPE` command. You can use the `MEASUrement:ANNOtations:STATE` command to display the gating in the graticule area.

Group

Measurement

Related Commands

```
MEASUrement:MEAS<x>:TYPE,
```

```
MEASUrement:ANNOtations:STATE
```

```
MEASUrement:MEAS:SOURCE:GATE:POS
```

```
MEASUrement:MEAS:SOURCE:GATE:PCTPos
```

Syntax 1

```
MEASUrement:MEAS<x>:GATing:STATE {ON|OFF|NR1}
```

Syntax 2:

```
MEASUrement:MEAS<x>:GATing:STATE?
```

Arguments

- ON
This argument enables the gating for the specified measurement.
- OFF
This argument disables the gating for the specified measurement.
- NR1
A 0 disables the gating for the specified measurement; any other value enables the gating for the specified measurement.

Example 1

```
MEASUREMENT:MEAS2:GATING:STATE ON
```

Enables the gating for Measurement 2.

Example 2

```
MEASUREMENT:MEAS1:GATING:STATE?
```

This query might return `MEASUREMENT:MEAS1:GATING:STATE 1`, indicating that gating is enabled for Measurement 1.

NOTE: A query always returns a 0 or 1.

MEASUREMENT:MEAS<x>:JITTER

This command sets or queries whether the jitter measurement should be made at the eye crossing of an eye pattern or at the mid reference level. Sending this command is equivalent to selecting Eye Cross or Mid Ref for the Jitter At field in the Eye section of the Region tab in the Measurement Setup dialog box. The Eye section is displayed only if you have an eye-pattern or optical measurement defined.

Group

Measurement

Syntax 1

```
MEASUREMENT:MEAS<x>:JITTER {EYECross|MIDref}
```

Syntax 2:

```
MEASUREMENT:MEAS<x>:JITTER?
```

Arguments

- EYECross
This argument causes the measurement for jitter to be taken at the eye crossing.
- MIDref
This argument causes the measurement for jitter to be taken at the mid reference level.

Example 1

```
MEASUREMENT:MEAS1:JITTER EYECross
```

This command causes the jitter measurement to be made at the eye crossing.

Example 2

MEASUrement:MEAS2:JITter?

This query might return :MEASUREMENT:MEAS2:JITTER MIDREF, indicating that Measurement 2 will measure jitter at the mid reference level.

MEASUrement:MEAS<x>:MAXimum?

Description

This query only command returns the maximum value found for the measurement slot specified by x, which can be 1 through 8, since the last statistical reset.

Group

Measurement

Related Commands

MEASUrement:MEAS<x>:ALL?

Syntax

MEASUrement:MEAS<x>:MAXimum?

Returns

NR3

Example

MEASUREMENT:MEAS3:MAXIMUM?

This query might return :MEASUREMENT:MEAS3:MAXIMUM
4.27246105395E-003, indicating that the maximum value for Meas
3 is 4.272 mV.

MEASUrement:MEAS<x>:MEAN?

This query only command returns the mean value accumulated for the measurement slot specified by x, which can be 1 through 8, since the last statistical reset.

Group

Measurement

Related Commands

MEASUrement:MEAS<x>:ALL?

Syntax

MEASUrement:MEAS<x>:MEAN?

Returns

NR3

Example

MEASUREMENT:MEAS1:MEAN?

This query might return :MEASUREMENT:MEAS1:MEAN
2.85516357276E-003, indicating that the mean value for Meas 1 is
2.855 mV.

MEASUREMENT:MEAS<x>:MINIMUM?

This query only command returns the minimum value found for the measurement slot specified by x, which can be 1 through 8, since the last statistical reset.

Group

Measurement

Related Commands

MEASUREMENT:MEAS<x>:ALL?

Syntax

MEASUREMENT:MEAS<x>:MINIMUM?

Returns

NR3

Example

MEASUREMENT:MEAS1:MINIMUM?

This query might return :MEASUREMENT:MEAS1:MINIMUM
1.92260747428E-003, indicating that the minimum value for Meas
1 is 1.923 mV.

MEASUREMENT:MEAS<x>:NOISE

This command sets or queries whether the noise measurement is made on the high or low level of the waveform. Sending this command is equivalent to selecting High or Low for the Noise At field in the Eye section of the Region tab in the Measurement Setup dialog box. The Eye section is displayed only if you have an eye-pattern or optical measurement defined.

Group

Measurement

Syntax 1

MEASUREMENT:MEAS<x>:NOISE {HIGH|LOW}

Syntax 2:

MEASUREMENT:MEAS<x>:NOISE?

Arguments

- HIGH
This argument causes the measurement for noise to be taken at the high level of the waveform.
- LOW
This argument causes the measurement for noise to be taken at the

low level of the waveform.

Example 1

```
MEASUrement:MEAS1:NOISe HIGH
```

This command causes the noise measurement to be made at the high level of the waveform for Measurement 1.

Example 2

```
MEASUrement:MEAS2:NOISe?
```

This query might return `:MEASUREMENT:MEAS2:NOISE LOW`, indicating that Measurement 2 will measure noise at the low level of the waveform.

MEASUrement:MEAS<x>:REFLevel<x>:ABSolute:HIGH

This command sets or queries the high reference level in absolute user units for the specified measurement. The measurement slot is specified by *x*, which can be 1 through 8. The reference level source is specified by *x*, which can only be 1 for this measurement (or defaults to 1 if not specified).

This absolute value is used as the high reference level when `MEASUrement:MEAS<x>:REFLevel<x>:METHod` is set to `ABSolute`. Sending this command is equivalent to selecting the `RefLevel` tab in the Measurement Setup dialog box, selecting `Absolute` in the Reference Level Calc Method section, and then entering an absolute value for `Hi` in the Reference section.

Group

Measurement

Related Commands

```
MEASUrement:MEAS<x>:REFLevel<x>:METHod
```

Syntax 1

```
MEASUrement:MEAS<x>:REFLevel<x>:ABSolute:HIGH <NR3>
```

Syntax 2

```
MEASUrement:MEAS<x>:REFLevel<x>:ABSolute:HIGH?
```

Argument

NR3

This argument is the high reference level in absolute user units. The default is 0 V.

Example 1

```
MEASUrement:MEAS3:REFLevel1:ABSolute:HIGH 2.0E-1
```

This command sets the high reference level for Measurement 3 to 200 mV.

Example 2

```
MEASUrement:MEAS2:REFLevel1:ABSolute:HIGH?
```

This query might return

```
:MEASUREMENT:MEAS2:REFLEVEL1:ABSOLUTE:HIGH  
9.00000000000E-2, indicating that the high reference level for  
Measurement 2 to is set to 90 mV.
```

MEASUrement:MEAS<x>:REFLevel<x>:ABSolute:LOW

This command sets or queries the low reference level in absolute user units for the specified measurement. The measurement slot is specified by x, which can be 1 through 8. The reference level source is specified x, which can only be 1 for this measurement (or defaults to 1 if not specified).

This absolute value is used as the low reference level when MEASUrement:MEAS<x>:REFLevel<x>:METHod is set to ABSolute. Sending this command is equivalent to selecting Absolute in the Reference Level Calc Method section of the RefLevel dialog and then entering an absolute value for Low in the Reference section of the Measurement Setup dialog box.

Group

Measurement

Related Commands

MEASUrement:MEAS<x>:REFLevel<x>:METHod

Syntax 1

```
MEASUrement:MEAS<x>:REFLevel<x>:ABSolute:LOW <NR3>
```

Syntax 2

```
MEASUrement:MEAS<x>:REFLevel<x>:ABSolute:LOW?
```

Argument

NR3

This argument is the low reference level in absolute user units. The default is 0 V.

Example 1

```
MEASUrement:MEAS3:REFLevel1:ABSolute:LOW 2.0E-2
```

This command sets the low reference level for Measurement 3 to 20 mV.

Example 2

```
MEASUrement:MEAS2:REFLevel1:ABSolute:LOW?
```

This query might return

```
:MEASUREMENT:MEAS2:REFLEVEL1:ABSOLUTE:LOW  
3.00000000000E-003, indicating that the low reference level for  
Measurement 2 to is set to 3 mV.
```

MEASUrement:MEAS<x>:REFLevel<x>:ABSolute:MID

This command sets or queries the mid reference level in absolute user units for the specified measurement. The measurement slot is specified by x, which can be 1 through 8. The reference level is specified by x (which corresponds to the Source1 or Source2 waveform) and can be 1

or 2. (You can set two different mid reference levels when taking measurements, such as phase or delay, between two source waveforms.)

This absolute value is used as the mid reference level when MEASUREMENT:MEAS<x>:REFLevel<x>:METHOD is set to ABSolute. Sending this command is equivalent to selecting ABSolute in the Reference Level Calc Method section of the RefLevel dialog and then entering an absolute value for Mid in the Reference section of the Measurement Setup dialog box.

Group

Measurement

Related Commands

MEASUREMENT:MEAS<x>:REFLevel<x>:METHOD

Syntax 1

MEASUREMENT:MEAS<x>:REFLevel<x>:ABSolute:MID <NR3>

Syntax 2

MEASUREMENT:MEAS<x>:REFLevel<x>:ABSolute:MID?

Argument

NR3

This argument is the mid reference level in absolute user units. The default is 0 V.

Example 1

MEASUREMENT:MEAS3:REFLevel2:ABSolute:MID 4.0E-2

This command sets the mid reference level for Measurement 3 on Source 2 to 40 mV.

Example 2

MEASUREMENT:MEAS2:REFLevel1:ABSolute:MID?

This query might return

:MEASUREMENT:MEAS2:REFLEVEL1:ABSOLUTE:MID
5.0000000000E-2, indicating that the mid reference level for Measurement 2 on Source 1 is set to 50 mV.

MEASUREMENT:MEAS<x>:REFLevel<x>:METHOD

This command sets or queries the method the instrument uses to calculate the reference levels for a specified measurement taken on a specified source waveform. The measurement slot is specified by x, which can be 1 through 8. The reference level is specified by x (which corresponds to the Source1 or Source2 waveform) and can be 1 or 2. Sending this command is equivalent to selecting the option button for the type of calculation in the Reference Level Calc Method section of the RefLevel dialog in the Measurement Setup dialog box.

The following diagram shows how each method calculates the High and Low reference levels.

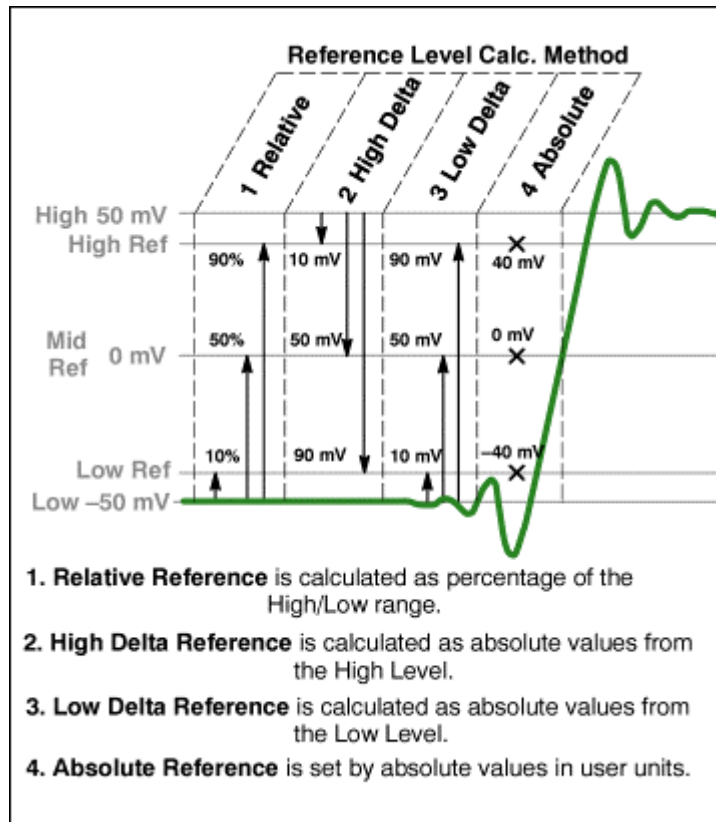

Group

Measurement

Related Commands

MEASUREMENT:MEAS<x>:REFLevel:ABSolute:HIGH,
 MEASUREMENT:MEAS<x>:REFLevel:ABSolute:LOW,
 MEASUREMENT:MEAS<x>:REFLevel:ABSolute:MID,
 MEASUREMENT:MEAS<x>:REFLevel:RELative:HIGH,
 MEASUREMENT:MEAS<x>:REFLevel:RELative:LOW,
 MEASUREMENT:MEAS<x>:REFLevel:RELative:MID

Syntax 1

MEASUREMENT:MEAS<x>:REFLevel<x>:METHOD {RELative
 |ABSolute|HIDelta|LODelta}

Syntax 2

MEASUREMENT:MEAS<x>:REFLevel<x>:METHOD?

Arguments

- RELative

This method calculates the reference levels as a percentage of the High/Low amplitude (High amplitude minus the Low amplitude). The default values are 90% for the high reference level, 10% for the low reference level, and 50% for the mid reference levels. You can set other percentages using the MEASUREMENT:MEAS<x>:REFLevel:RELative commands (see related commands above).

- **ABSolute**
This method uses reference levels set explicitly in absolute user units with the `MEASUREMENT:MEAS<x>:REFLevel:ABSolute` commands (see related commands above). This method is useful when precise values are required (for example, when you are designing to published interface specifications such as RS-232-C). The default values are 0 V for the high reference level, the low reference level, and the mid reference levels.
- **HIDelta**
This method sets the reference levels as absolute amplitude delta values from the High level.
- **LODelta**
This method sets the reference levels as absolute amplitude delta values from the Low level.

Example 1

```
MEASUREMENT:MEAS1:REFLevel1:METHOD RELative
```

This command sets the method of calculating the reference levels to relative for Measurement 1; the default values are 90% for the high reference level, 50% for the mid reference level, and 10% for the low reference level.

Example 2

```
MEASUREMENT:MEAS8:REFLevel1:METHOD?
```

This query might return

```
:MEASUREMENT:MEAS8:REFLEVEL1:METHOD ABSOLUTE,
```

indicating the reference levels used are set to absolute values in user units.

MEASUREMENT:MEAS<x>:REFLevel<x>:RELative:HIGH

This command sets or queries the percent of the High/Low range that the instrument uses to calculate the high reference level for the specified measurement, where 100% is equal to the High/Low range. The measurement slot is specified by `x`, which can be 1 through 8. The reference level source is specified `x`, which can only be 1 for this measurement (or defaults to 1 if not specified).

This percentage is used to calculate the high reference level when `MEASUREMENT:MEAS<x>:REFLevel<x>:METHOD` is set to `RELative`. Sending this command is equivalent to selecting `Relative` in the `Reference Level Calc Method` section of the `RefLevel` dialog and then entering a percentage for `Hi` in the `Reference` section of the `Measurement Setup` dialog box.

Group

Measurement

Related Commands

```
MEASUREMENT:MEAS<x>:REFLevel<x>:METHOD
```

Syntax 1

MEASUrement:MEAS<x>:REFLevel<x>:RELative:HIGH <NR2>

Syntax 2

MEASUrement:MEAS<x>:REFLevel<x>:RELative:HIGH?

Argument

NR2

This argument can be from 0 to 100 (percent) and is the high reference level. The default is 90 (percent).

Example 1

MEASUrement:MEAS3:REFLevel1:RELative:HIGH 95

This command sets the high reference level for Measurement 3 to 95% of the High/Low range.

Example 2

MEASUrement:MEAS2:REFLevel1:RELative:HIGH?

This query might return

:MEASUREMENT:MEAS2:REFLEVEL1:PERCENT:HIGH
9.000000000000E+001, indicating that the high reference level for Measurement 2 to is set to 90% (the default value) of the High/Low range.

MEASUrement:MEAS<x>:REFLevel<x>:RELative:LOW

This command sets or queries the percent of the High/Low range that the instrument uses to calculate the low reference level for the specified measurement, where 100% is equal to the High/Low range. The measurement slot is specified by x, which can be 1 through 8. The reference level source is specified x, which can only be 1 for this measurement (or defaults to 1 if not specified).

This percentage is used to calculate the low reference level when MEASUrement:MEAS<x>:REFLevel<x>:METHod is set to RELative. Sending this command is equivalent to selecting Relative in the Reference Level Calc Method section of the RefLevel dialog and then entering a percentage for Low in the Reference section of the Measurement Setup dialog box.

Group

Measurement

Related Commands

MEASUrement:MEAS<x>:REFLevel<x>:METHod

Syntax 1

MEASUrement:MEAS<x>:REFLevel<x>:RELative:LOW <NR2>

Syntax 2

MEASUrement:MEAS<x>:REFLevel<x>:RELative:LOW?

Argument

NR2

This argument can be from 0 to 100 (percent) and is the low reference level. The default is 10 (percent).

Example 1

```
MEASUrement:MEAS3:REFLevel1:RELative:Low 20
```

This command sets the low reference level for Measurement 3 to 20% of the High/Low range.

Example 2

```
MEASUrement:MEAS2:REFLevel1:RELative:LOW?
```

This query might return

```
:MEASUREMENT:MEAS2:REFLEVEL1:RELATIVE:LOW 10,
```

indicating that the low reference level for Measurement 2 is set to 10% (the default value) of the High/Low range.

MEASUrement:MEAS<x>:REFLevel<x>:RELative:MID

This command sets or queries the percent of the High/Low range that the instrument uses to calculate the mid reference level for the specified measurement, where 100% is equal to the High/Low range. The measurement slot is specified by *x*, which can be 1 through 8. The reference level is specified by *x* (which corresponds to the Source1 or Source2 waveform) and can be 1 or 2. (You can set two different mid reference levels when taking measurements, such as phase or delay, between two source waveforms.)

This percentage is used to calculate the mid reference level when MEASUrement:MEAS<x>:REFLevel<x>:METHod is set to RELative. Sending this command is equivalent to selecting Relative in the Reference Level Calc Method section of the RefLevel dialog and then entering a percentage for Mid in the Reference section of the Measurement Setup dialog box.

Group

Measurement

Related Commands

```
MEASUrement:MEAS<x>:REFLevel<x>:METHod
```

Syntax 1

```
MEASUrement:MEAS<x>:REFLevel<x>:RELative:MID <NR2>
```

Syntax 2

```
MEASUrement:MEAS<x>:REFLevel<x>:RELative:MID?
```

Argument

NR2

This argument can be from 0 to 100 (percent) and is the mid reference level. The default is 50 (percent).

Example 1

```
MEASUrement:MEAS3:REFLevel2:RELative:MID 40
```

This command sets the mid reference level for Measurement 3 on Source 2 to 40% of the High/Low range.

Example 2

```
MEASUrement:MEAS2:REFLevel1:RELative:MID?
```

This query might return

```
:MEASUREMENT:MEAS2:REFLEVEL1:PERCENT:LOW  
5.000000000000E+001, indicating that the mid reference level for  
Measurement 2 on Source 1 is set to 50% (the default value) of the  
High/Low range.
```

MEASUrement:MEAS<x>:REFLevel<x>?

This is a query only command that returns all reference level <x> settings for measurement slot <x> (slot one through slot eight).

Group

Measurement

Syntax

```
MEASUrement:MEAS<x>:REFLevel?
```

Example

```
MEASUrement:MEAS1:REFLevel?
```

This query might return

```
:MEASUREMENT:MEAS1:REFLEVEL1:METHOD RELATIVE;  
ABSOLUTE:HIGH 0.000000000000E+000;  
LOW 0.000000000000E+000;MID 0.000000000000E+000;  
:MEASUREMENT:MEAS1:REFLEVEL1:RELATIVE:  
HIGH 9.000000000000E+001;LOW 1.000000000000E+001;  
MID 5.000000000000E+001
```

MEASUrement:MEAS<x>:SETDefault

This command (no query form) sets all the parameters for the measurement specified by x, which can be 1 through 8, to the factory default settings. This command affects only measurement parameters.

Group

Measurement

Syntax

```
MEASUrement:MEAS<x>:SETDefault
```

Example

```
MEASUrement:MEAS3:SETDefault
```

This command sets the parameters for Measurement 3 to their factory default settings.

MEASUrement:MEAS<x>:SOURCE<x>:EDGE:DIRection

This command sets or queries the direction that the instrument uses to look for the rising or falling edge of the specified waveform when taking the specified measurement. This command affects only Delay, Ncross and Pcross measurements. The measurement slot is specified by x, which

can be 1 through 8; the source waveform is specified by x, which can be 1 or 2.

Sending this command is equivalent to selecting an option button (→ or ←) for Direction in the Edges section of the Region dialog in the Measurement Setup dialog box.

Group

Measurement

Related Commands

MEASUrement:MEAS<x>:GATing:STATE,
MEASUrement:MEAS<x>:SOURCE<x>:EDGE:SLOPe

Syntax 1

```
MEASUrement:MEAS<x>:SOURCE<x>:EDGE:DIRection  
{FORward|BACKward}
```

Syntax 2

```
MEASUrement:MEAS<x>:SOURCE<x>:EDGE:DIRection?
```

Arguments

- **FORward**
This argument causes the instrument to search forward from the beginning of the waveform (or gated region) and find the first edge with the slope set by the MEASUrement:MEAS<x>:SOURCE<x>:EDGE:SLOPe command (delay measurements) or for the edge implicitly determined by the defined measurement.
- **BACKward**
This argument causes the instrument to search backward from the end of the waveform (or gated region) and find the last edge with the slope set by the MEASUrement:MEAS<x>:SOURCE<x>:EDGE:SLOPe command (delay measurements) or for the edge implicitly determined by the defined measurement.

Example 1

```
MEASUrement:MEAS2:SOURCE1:EDGE:DIRection FORWARD
```

This command causes the instrument to search forward from the beginning of the Source 1 waveform (or the beginning of the gated region, if gates are enabled) for the first specified edge (rising or falling)

Example 2

```
MEASUrement:MEAS8:SOURCE1:EDGE:DIRection?
```

This query might return

```
:MEASUREMENT:MEAS8:SOURCE1:EDGE:DIRECTION  
FORWARD, indicating that the instrument will search forward from the  
beginning of the Source 1 waveform (or the beginning of the gated  
region, if gates are enabled) for the specified edge (rising or falling)  
when taking Measurement 8.
```

MEASUREMENT:MEAS<x>:SOURCE<x>:EDGE:SLOPe

This command sets or queries the slope (or polarity) of the edges used in delay time measurements. The measurement slot is specified by x, which can be 1 through 8; the source is specified by x, which can be 1 (source waveform) or 2 (destination waveform). For edge measurements other than delay, the slope is determined implicitly (for example, rise time measurements use positive slopes). If gates are enabled (see the MEASUREMENT:MEAS<x>:GATING:STATE command), the instrument finds the edge within the measurement zone; otherwise, the instrument finds the edge within the entire waveform record.

Sending this command is equivalent to selecting an option button (\pm , +, or $-$) for Slope in the Edges section of the Region dialog in the Measurement Setup dialog box. (A delay measurement must be selected before these buttons are active.)

Use the MEASUREMENT:MEAS<x>:SOURCE:EDGE:DIRrection command to set the direction that the instrument uses to look for the rising or falling edge of the waveforms.

Group

Measurement

Syntax 1

```
MEASUREMENT:MEAS<x>:SOURCE<x>:EDGE:SLOPe {RISE|FALL|EITHER}
```

Syntax 2

```
MEASUREMENT:MEAS<x>:SOURCE<x>:EDGE:SLOPe?
```

Arguments

- RISE
This argument causes the instrument to take the specified measurement on a rising (positive-going) edge of the specified source waveform.
- FALL
This argument causes the instrument to take the specified measurement on a falling (negative-going) edge of the specified source waveform.
- EITHER
This argument causes the instrument to take the specified measurement on either a rising (positive-going) or falling (negative-going) edge of the specified source waveform.

Example 1

```
MEASUREMENT:MEAS4:SOURCE1:EDGE:SLOPe RISE
```

This command causes the instrument to take the delay for Measurement 4 from a rising edge of the Source 1 waveform.

Example 2

```
MEASUREMENT:MEAS4:SOURCE2:EDGE:SLOPe?
```

This query might return

```
:MEASUREMENT:MEAS4:SOURCE2:EDGE:SLOPE FALL,  
indicating that the delay for Measurement 4 is taken to a falling edge of  
the Source 2 (destination) waveform.
```

MEASUREMENT:MEAS<x>:SOURCE<x>:EDGE?

This query only command returns edge parameters (slope and direction) for the specified measurement slot using the specified source. The measurement slot is specified by x, which can be 1 through 8. The Source is specified by x, which can be 1 or 2.

Measurement

Syntax

```
MEASUREMENT:MEAS<x>:SOURCE<x>:EDGE?
```

Example

```
MEASUREMENT:MEAS<x>:SOURCE<x>:EDGE?
```

This query might return

```
:MEASUREMENT:MEAS4:SOURCE1:EDGE:SLOPE  
FALL;DIRECTION FORWARD.
```

MEASUREMENT:MEAS<x>:SOURCE<x>:GATE<x>:PCTPOS

This command sets or queries the position (in percentage of the waveform) of the source gates for the measurement. The measurement, source, and gate are defined as follows:

- MEAS<x> where x can be 1 through 8 (a maximum of 8 measurement slots)
- SOURCE<x> where x can be 1 or 2 (a maximum of 2 source waveforms)
- GATE<x> where x can be 1 or 2 (one pair of gates per source waveform)

Gates are generic, nondirectional markers that segment the area of waveform data over which measurements are performed. There is no distinction in gates of stop or start, so they can cross.

You use this command to set the position of a gate as a percentage of the waveform. This is equivalent to selecting the Region dialog in the Measurement Setup dialog box and entering the position as a percentage of the waveform in the G1 or G2 control in the Gates section.

Note that a user cannot directly set the position of a gate in the Measurement Setup dialog box using waveform units. Instead, the user sets the percentage of the waveform at which the gate is positioned, and then the position in waveform units is displayed in the readout boxes adjacent to the G1 and G2 controls. However, you can directly set the gate position in waveform units with the GPIB command, MEASUREMENT:MEAS<x>:SOURCE<x>:GATE<x>:POS.

Group

Measurement

Related Commands

```
MEASUREMENT:MEAS<x>:SOURCE<x>:GATE<x>:POS
```

MEASUREMENT:MEAS<x>:GATING:STATE

Syntax 1

MEASUREMENT:MEAS<x>:SOURCE<x>:GATE<x>:PCTPOS <NR2>

Syntax 2

MEASUREMENT:MEAS<x>:SOURCE<x>:GATE<x>:PCTPOS?

Arguments

NR2

This argument is the position of the specified gate in percentage.

Example 1

MEASUREMENT:MEAS4:SOURCE1:GATE1:PCTPOS 25

This command sets Gate 1 to 25% on the Source 1 waveform used for Measurement 4.

Example 2

MEASUREMENT:MEAS2:SOURCE1:GATE2:PCTPOS?

This query might return

:MEASUREMENT:MEAS2:SOURCE1:GATE2:PCTPOS

8.000000000000E+001, indicating that Gate 2 is set at 80% on the Source 1 waveform used for Measurement 2.

MEASUREMENT:MEAS<x>:SOURCE<x>:GATE<x>:POS

This command sets or queries the position (in waveform units) of the source gates for the measurement. The measurement, source, and gate are defined as follows:

- MEAS<x>, where x can be 1 through 8 (a maximum of 8 measurement slots)
- SOURCE<x>, where x can be 1 or 2 (a maximum of 2 source waveforms)
- GATE<x>, where x can be 1 or 2 (one pair of gates per source waveform)

Gates are generic, nondirectional markers that segment the area of waveform data over which measurements are performed. There is no distinction in gates of stop or start, so they can cross.

Although you can use this command to set the position of a gate in waveform units, a user cannot directly set the position of a gate in the Measurement Setup dialog box using waveform units. Instead, the user selects the Region dialog, enters the position as a percentage of the waveform, and then reads the position in waveform units in the readouts adjacent to the percentage controls for G1 and G2. This is equivalent to setting the position with the

MEASUREMENT:MEAS<x>:SOURCE<x>:GATE<x>:PCTPOS command.

Group

Measurement

Related Commands

MEASUrement:MEAS<x>:SOURCE<x>:GATE<x>:PCTPOS

MEASUrement:MEAS<x>:GATing:STATE

Syntax 1

MEASUrement:MEAS<x>:SOURCE<x>:GATE<x>:POS <NR3>

Syntax 2

MEASUrement:MEAS<x>:SOURCE<x>:GATE<x>:POS?

Arguments

NR3

This argument is the position of the specified gate in waveform units. The position is constrained to be \geq TOFP (time of first point) and \leq TOLP (time of last point).

Example 1

MEASUrement:MEAS4:SOURCE1:GATE1:POS 1.9E-8

This command sets Gate 1 to 19 ns on the Source 1 waveform used for Measurement 4 relative to the trigger.

Example 2

MEASUrement:MEAS2:SOURCE1:GATE2:POS?

This query might return

:MEASUREMENT:MEAS2:SOURCE1:GATE2:POS

2.29100000000E-008, indicating that Gate 2 is set at 22.91 ns on the Source 1 waveform used for Measurement 2.

MEASUrement:MEAS<x>:SOURCE<x>:GATE<x>?

This query-only command returns all gate settings of the specified gate for the specified measurement on the specified source waveform. The measurement slot is specified by x, which can be 1 through 8; the source is specified by x, which can be 1 or 2; and the gate is specified by x, which can be 1 or 2.

Group

Measurement

Syntax

MEASUrement:MEAS<x>:SOURCE<x>:GATE<x>?

Example

MEASUrement:MEAS1:SOURCE1:GATE1?

This query might return :MEASUREMENT:MEAS1:SOURCE1:GATE1:POS 20.25000000000E-9;PCTPOS 25.0000000000

MEASUrement:MEAS<x>:SOURCE<x>:HILow:METHOD

This command sets or queries the method of calculating the high/low levels for a specified measurement on a specified source waveform. The measurement slot is specified by x, which can be 1 through 8; the source

is specified by x, which can be 1 or 2. Sending this command is equivalent to specifying a measurement slot (such as Meas 3), selecting a source (such as Source1), and then checking the radio button for the desired Tracking Method in the in the Hi/Low pane of the Measurement Setup dialog box.

The exact value of High and Low depends on which calculation method you set.

Group

Measurement

Syntax 1

```
MEASUrement:MEAS<x>:SOURCE<x>:HILow:METHOD  
{AUTO|MODE|MINMax|MEAN}
```

Syntax 2

```
MEASUrement:MEAS<x>:SOURCE<x>:HILow:METHOD?
```

Arguments

- AUTO

The AUTO mode attempts to use the most appropriate method of calculating the high and low values for the specified signal type. If the signal type is set to Eye, the instrument defaults to the Mean method of calculating the high and low values. If the signal type is set to Pulse, the instrument defaults to the Mode method of calculating the high and low values. However, the instrument will automatically switch to the Min/Max method if the histogram used to track the high and low values does not show an obvious consistent high level or to the Mean method if the histogram shows at least two different concentrations of peak values. For example, the Mode histogram operating on a triangle wave would not find significant high and low levels, and the instrument would switch to the Min/Max mode. On a square wave, the Auto mode would use the Mode method to calculate the high and low values.

- MODE

This method of calculating the high and low values attempts to find, using a histogram, the highest density of points above and below the waveform midpoint. See the figure below. It attempts to ignore ringing and spikes when determining the 0% and 100% levels. This method works well when measuring square waves and pulse waveforms.

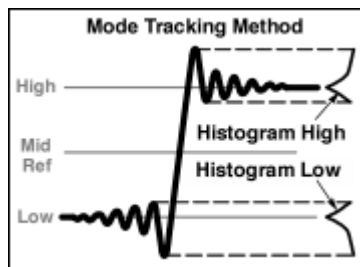

- MINMax

This method of calculating the high and low values defines the 0% and 100% waveform levels as the lowest amplitude (most negative) and the highest amplitude (most positive) samples. See the figure below. This method is useful for measuring frequency, width, and period for many types of signals. However, this method is sensitive to waveform ringing and spikes and does not always accurately measure rise time, fall time, overshoot, and undershoot.

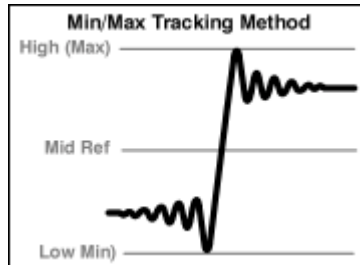

- MEAN

This method of calculating the high and low values is commonly used for eye diagrams. The mean method calculates the high value as the mean value of the region above the mid reference and the low value as the mean value of the region below the mid reference. See the figure below. The mean is computed only over the eye aperture - typically the center 20% of the NRZ eye, or the center 5% of an RZ eye.

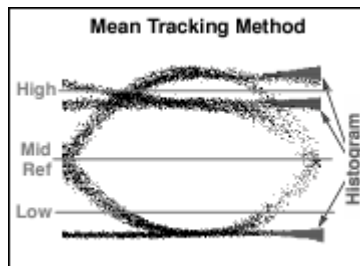

Example 1

```
MEASUREMENT:MEAS2:SOURCE1:HIGHLow:METHOD MINMax
```

This command selects the Min/Max method of determining the high and low values used to take measurements defined by Meas2 on the Source 1 waveform.

Example 2

```
MEASUREMENT:MEAS1:SOURCE1:HIGHLow:METHOD?
```

This query Might return

```
:MEASUREMENT:MEAS1:SOURCE1:HIGHLow:METHOD MINMAX,
```

indicating that the Min/Max method of calculating the High/Low levels is used for Meas1 on the Source 1 waveform.

MEASUREMENT:MEAS<x>:SOURCE<x>:HILow:TRACK:HIGH:ENABLE

This command sets or queries whether tracking of the high value for a specified measurement on a specified source waveform is automatically

done by the instrument. The measurement slot is specified by *x*, which can be 1 through 8; the source is specified by *x*, which can be 1 or 2. Sending this command is equivalent to specifying a measurement slot (such as Meas 3), selecting a source (such as Source1), and then checking the control box for Track High in the in the Hi/Low pane of the Measurement Setup dialog box. (If tracking is enabled, the instrument automatically calculates the high value using the method set with the command, MEASUrement:MEAS<*xx*

Group

Measurement

Related Commands

MEASUrement:MEAS<*xxMEASUrement:MEAS<*xxENABLE**

Syntax 1

```
MEASUrement:MEAS<xx:ENABLE {ON|OFF|NR1}
```

Syntax 2

```
MEASUrement:MEAS<xx:ENABLE?
```

Arguments

- ON
This argument enables tracking of the high value for the specified measurement on the specified source waveform.
- OFF
This argument disables tracking of the high value for the specified measurement on the specified source waveform.
- NR1
A 0 disables tracking of the high value for the specified measurement on the specified source waveform; any other value enables tracking of the high value for the specified measurement on the specified source waveform.

Example 1

```
MEASUrement:MEAS2:SOURCE1:HILOw:TRACK:HIGH:ENABLE ON
```

This command enables tracking of the high value used to take Measurement 2 on the Source 1 waveform.

Example 2

```
MEASUrement:MEAS3:SOURCE2:HILOw:TRACK:HIGH:ENABLE?
```

This query might return

```
:MEASUREMENT:MEAS3:SOURCE2:HILOW:TRACK:HIGH:  
ENABLE 0, indicating that the tracking of the high value for  
Measurement 3 on the Source 2 waveform is disabled.
```

NOTE: A query always returns a 0 or 1.

MEASUREMENT:MEAS<x>:SOURCE<x>:HILOW:TRACK:HIGH:VALUE

This command sets or queries the high value used to calculate a specified measurement on a specified source waveform. The measurement slot is specified by x, which can be 1 through 8; the source is specified by x, which can be 1 or 2. Sending this command is equivalent to selecting a measurement slot (such as Meas 3), selecting a source (such as Source 1), turning tracking High off, and then entering an absolute value in the High control box in the in the Hi/Low pane of the Measurement Setup dialog box. (If tracking is enabled for High, the instrument automatically calculates the high value using the method set with the command, MEASUREMENT:MEAS<x>:SOURCE<x>:HILOW:METHOD.)

Group

Measurement

Related Commands

MEASUREMENT:MEAS<x>:SOURCE<x>:HILOW:METHOD,
MEASUREMENT:MEAS<x>:SOURCE<x>:HILOW:TRACK:HIGH:
ENABLE

Syntax 1

```
MEASUREMENT:MEAS1:SOURCE1:HILOW:TRACK:HIGH:VALUE  
<NR3>
```

Syntax 2

```
MEASUREMENT:MEAS1:SOURCE1:HILOW:TRACK:HIGH:VALUE?
```

Argument

NR3

This argument is the absolute value of the high level for the HiLow settings.

Example 1

```
MEASUREMENT:MEAS2:SOURCE1:HILOW:TRACK:HIGH:VALUE  
5.0E-1
```

This command sets the high value used to take Measurement 2 on the Source 1 waveform to 500 mV.

Example 2

```
MEASUREMENT:MEAS1:SOURCE1:HILOW:TRACK:HIGH:VALUE?
```

This query might return

```
:MEASUREMENT:MEAS1:SOURCE1:HILOW:TRACK:HIGH  
:VALUE 2.00000000000E-001, indicating that the high value used  
to take Measurement 3 on the Source 1 waveform is 200 mV.
```

MEASUREMENT:MEAS<x>:SOURCE<x>:HILow:TRACK:LOW:ENABLE

This command sets or queries whether tracking of the low value for a specified measurement on a specified source waveform is automatically done by the instrument. The measurement slot is specified by *x*, which can be 1 through 8; the source is specified by *x*, which can be 1 or 2. Sending this command is equivalent to specifying a measurement slot (such as Meas 3), selecting a source (such as Source 1), and then checking the control box for Track Low in the in the HiLow dialog of the Measurement Setup dialog box. (If tracking is enabled, the instrument automatically calculates the low value using the method set with the command, MEASUREMENT:MEAS<x>:SOURCE<x>:HILow:METHod.)

Group

Measurement

Related Commands

MEASUREMENT:MEAS<x>:SOURCE<x>:HILow:METHod,
MEASUREMENT:MEAS<x>:SOURCE<x>:HILow:TRACK:HIGH:
ENABLE

Syntax 1

```
MEASUREMENT:MEAS<x>:SOURCE<x>:HILow:TRACK:LOW:ENABLE {ON|OFF|NR1}
```

Syntax 2

```
MEASUREMENT:MEAS<x>:SOURCE<x>:HILow:TRACK:LOW:ENABLE?
```

Arguments

- ON
This argument enables tracking of the low value for the specified measurement on the specified source waveform.
- OFF
This argument disables tracking of the low value for the specified measurement on the specified source waveform.
- NR1
A 0 disables tracking of the low value for the specified measurement on the specified source waveform; any other value enables tracking of the low value for the specified measurement on the specified source waveform.

Example 1

```
MEASUREMENT:MEAS2:SOURCE1:HILow:TRACK:LOW:ENABLE ON
```

This command enables tracking of the low value used to take Measurement 2 on the Source 1 waveform.

Example 2

```
MEASUREMENT:MEAS3:SOURCE2:HILow:TRACK:LOW:ENABLE?
```

This query might return
:MEASUREMENT:MEAS3:SOURCE2:HILOW:TRACK:LOW:
ENABLE 0, indicating that the tracking of the low value for
Measurement 3 on the Source 2 waveform is disabled.

NOTE: A query always returns a 0 or 1.

MEASUREMENT:MEAS<x>:SOURCE<x>:HILOW:TRACK :LOW:VALUE

This command sets or queries the low value used to calculate a specified measurement on a specified source waveform. The measurement slot is specified by x, which can be 1 through 8; the source is specified by x, which can be 1 or 2. Sending this command is equivalent to selecting a measurement slot (such as Meas 3), selecting a source (such as Source 1), setting tracking Low to off, and then entering an absolute value in the Low control box in the in the Hi/Low pane of the Measurement Setup dialog box. (If tracking is enabled for Low, the instrument automatically calculates the low value using the method set with the command, MEASUREMENT:MEAS<x>:SOURCE<x>:HILOW:METHOD.)

Group

Measurement

Related Commands

MEASUREMENT:MEAS<x>:SOURCE<x>:HILOW:METHOD,
MEASUREMENT:MEAS<x>:SOURCE<x>:HILOW:TRACK:LOW:
ENABLE

Syntax 1

MEASUREMENT:MEAS2:SOURCE1:HILOW:TRACK:LOW:VALUE <NR3>

Syntax 2

MEASUREMENT:MEAS2:SOURCE1:HILOW:TRACK:LOW:VALUE?

Argument

NR3

This argument is the absolute value of the low level for the HiLow settings.

Example 1

MEASUREMENT:MEAS2:SOURCE1:HILOW:TRACK:LOW:VALUE 5.0E-3

This command sets the low value used to take Measurement 2 on the Source 1 waveform to 5 mV.

Example 2

MEASUREMENT:MEAS3:SOURCE1:HILOW:TRACK:LOW:VALUE?

This query might return :MEASUREMENT:MEAS3:SOURCE1
:HILOW:TRACK:LOW:VALUE 1.00000000000E-002, indicating
that the low value used to take Measurement 3 on the Source 1 waveform
is 10 mV.

MEASUREMENT:MEAS<x>:SOURCE<x>:HILOW?

This query only command returns all the High/Low settings for the specified measurement taken on the specified source waveform. The measurement slot is specified by x, which can be 1 through 8; the source is specified by x, which can be 1 or 2.

Group

Measurement

Syntax

```
MEASUREMENT:MEAS<x>:SOURCE<x>:HIGHLOW?
```

Example

```
MEASUREMENT:MEAS1:SOURCE1:HIGHLOW?
```

This query might return

```
:MEASUREMENT:MEAS1:SOURCE1:HILOW:METHOD AUTO;  
TRACK:HIGH:ENABLE 1;VALUE 2.000000000000E-001;  
:MEASUREMENT:MEAS1:SOURCE1:HILOW:TRACK:LOW:ENABLE  
1;  
VALUE 1.000000000000E-002.
```

MEASUREMENT:MEAS<x>:SOURCE<x>:WFM

This command sets or queries the source waveform (SOURCE1) on which the specified single-channel measurements are taken and **from which** two-channel measurements, such as delay or phase are taken. The measurement slot is specified by x, and can be 1 through 8. This command also sets or queries the destination waveform (SOURCE2) **to which** two-channel measurements are taken. If the source is not specified (either 1 or 2), the default is SOURCE1. Optionally, this command can specify the timebase for the specified source or destination waveform. If the timebase is not specified, the default is the Main timebase.

Group

Measurement

Syntax 1

```
MEASUREMENT:MEAS<x>:SOURCE<x>:WFM {CH<x>} | MATH<x>  
| REF<x>} [ , {MAIN | MAG1 | MAG2} ]
```

Syntax 2

```
MEASUREMENT:MEAS<x>:SOURCE<x>:WFM?
```

Arguments

- CH<x>
This argument selects a channel waveform as the source or destination waveform. The range for x is 1 through 8.
- MATH<x>
This argument selects a math waveform as the source or destination waveform. The range for x is 1 through 8.
- REF<x>

This argument selects a reference waveform as the source or destination waveform. The range for x is 1 through 8.

- **MAIn**
This optional argument selects Main as the timebase for the specified source or destination waveform. This is the default timebase.
- **MAG1**
This optional argument selects MAG1 as the timebase for the specified source or destination waveform (for channels and math).
- **MAG2**
This optional argument selects MAG2 as the timebase for the specified source or destination waveform for channels and math).

Example 1

```
MEASUrement:MEAS2:SOURCE1:WFM MATH1
```

This command sets MATH1 as the source waveform for Measurement 2

Example 2

```
MEASUrement:MEAS2:SOURCE1:WFM?
```

This query might return :MEASUREMENT:MEAS1:SOURCE1:WFM CH3,MAIN, indicating that the source waveform for Measurement 1 is Channel 3 using the Main timebase.

MEASUrement:MEAS<x>:SOURCE<x>:WFMDB:SIGType

This command sets or queries the type of input signal used to populate the waveform database associated with the specified measurement slot, MEAS<x>, where x can be 1 through 8, and the specified measurement source, SOURCE<x>, where x can be 1 or 2. To ensure accurate measurement results, always use this command to specify the input-signal type of the measurement source if your measurement is taken on a waveform database. Sending this command is equivalent to selecting Pulse, NRZ (Non-Return to Zero), or RZ (Return to Zero) as the Signal Type in the Source pane of the Measurement Setup dialog box.

Group

Measurement

Related Commands

```
MEASUrement:MEAS<X>:SOURCE<x>:WFMDB:STATE
```

Syntax 1

```
MEASUrement:MEAS<x>:SOURCE<x>:WFMDB:SIGType  
{PULSE|EYE|RZ}
```

Syntax 2

```
MEASUrement:MEAS<x>:SOURCE<x>:WFMDB:SIGType?
```

Arguments

- PULSE
Use this signal type for generic signals that are not associated with synchronous communications standards
- EYE
Use this signal type for synchronous-communication signals with NRZ (non-return to zero) characteristics.
- RZ
Use this signal type for synchronous communication signals with RZ (return to zero) characteristics.

Example 1

```
MEASUrement:MEAS5:SOURCE1:WFMDB:SIGType PULSE
```

This command selects Pulse as the signal type associated with source 1 for measurement slot 5.

Example 2

```
MEASUrement:MEAS2:SOURCE1:WFMDB:SIGType?
```

This query might return :MEASUREMENT:MEAS2:SOURCE1:WFMDB:SIGTYPE RZ, indicating that the signal type associated with source 1 of measurement slot 2 is RZ.

MEASUrement:MEAS<x>:SOURCE<x>:WFMDB:STATE

This command sets or queries whether the specified measurement is taken on the specified waveform or a waveform database built from the targeted source. The measurement slot is specified by x, which can be 1 through 8; the source waveform is specified by x, which can be 1 or 2. Sending this command is equivalent to selecting a measurement and a source in the Measurement Setup dialog box, and then selecting or clearing the Use Wfm Database check box in the Source dialog of the Measurement Setup dialog box.

Group

Measurement

Related Commands

```
MEASUrement:MEAS<x>:SOURCE<x>:WFMDB:SIGType
```

Syntax 1

```
MEASUrement:MEAS<x>:SOURCE<x>:WFMDB:STATE  
{ON|OFF|NR1}
```

Syntax 2

MEASUrement:MEAS<x>:SOURCE<x>:WFMDB:STATE?

Arguments

- ON
This argument enables the database measurement for the specified source waveform so that the measurement is made on the database.
- OFF
This argument disables the database measurement so that the measurement is taken directly on the acquired waveform.
- NR1
A 0 disables the database measurement; any other value enables the database measurement.

Example 1

MEASUrement:MEAS5:SOURCE1:WFMDB:STATE ON

This command causes Measurement 5 to be taken on the Source 1 waveform database.

Example 2

MEASUrement:MEAS<x>:SOURCE<x>:WFMDB:STATE?

This query might return :MEASUREMENT:MEAS2:SOURCE1:WFMDB:STATE 0, indicating that Measurement 2 will be taken on the Source 1 waveform.

NOTE: A query always returns a 0 or 1.

MEASUrement:MEAS<x>:STATE

This command sets or queries whether the specified measurement slot is computed and displayed. The measurement slot is specified by x, which can be 1 through 8. Sending this command is equivalent to selecting a measurement slot (such as Meas 3) and checking the On box in the Measurement Setup dialog box.

For a measurement to display, you must have selected a source waveform and defined the measurement you want take and display. You select the measurement source with the MEASUrement:MEAS<x>:SOURCE<x>:WFM command. You define the measurement type with the MEASUrement:MEAS<x>:TYPE command.

Group

Measurement

Related Commands

MEASUrement:MEAS<x>:SOURCE<x>:WFM,
MEASUrement:MEAS<x>:TYPE

Syntax 1

MEASUrement:MEAS<x>:STATE {OFF|ON|<NR1>}

Syntax 2

MEASUrement:MEAS<x>:STATE?

Arguments

- OFF
This argument disables the calculation and display of the measurement defined in the specified measurement slot.
- ON
This argument enables the calculation and display of the measurement defined in the specified measurement slot.
- NR1
A 0 disables the calculation and display of the specified measurement slot; any other value enables the calculation and display of the specified measurement slot.

Example 1

MEASUREMENT:MEAS1:STATE ON

This command displays the measurement defined in measurement slot 1.

Example 2

MEASUREMENT:MEAS4:STATE?

This query might return :MEASUREMENT:MEAS4:STATE 1, indicating that the measurement defined for measurement slot 4 is displayed.

NOTE: A query always returns a 0 or 1.

MEASUrement:MEAS<x>:STATIstics:CLEAr

This command (no query form) clears and restarts the calculation of the statistics for the measurement slot specified by x, which can be 1 through 8.

Group

Measurement

Related Commands

MEASUrement:STATIstics:ENABle

Syntax 1

MEASUrement:MEAS<x>:STATIstics:CLEAr

Example

MEASUrement:MEAS3:STATIstics:CLEAr

This command clears and restarts calculating the statistics for Measurement 3.

MEASUREMENT:MEAS<x>:STDdev?

This query only command returns the standard deviation of values accumulated for the measurement slot specified by x, which can be 1 through 8, since the last statistical reset.

Group

Measurement

Related Commands

MEASUREMENT:MEAS<x>:ALL

Syntax

MEASUREMENT:MEAS<x>:STDdev?

Returns

NR3

Example

MEASUREMENT:MEAS1:STDDEV?

This query might return :MEASUREMENT:MEAS1:STDDEV
1.16796169259E-011, indicating that the standard deviation for Measurement 1 is 11.8 ps.

MEASUREMENT:MEAS<x>:TYPE

This command sets or queries the measurement type assigned to the specified measurement slot, where x is one of the available measurement slots from 1 through 8. If the specified measurement slot is already assigned, selecting a new measurement type will re-assign the specified slot to the requested measurement type. Sending this command is equivalent to using the pulldown list to select the type of measurement you want to take, after first selecting the measurement slot (such as Meas 1) and a source-signal type (such a NRZ), in the Meas Setup dialog box.

Note. All of the measurement types require at least one source waveform to be specified with the MEASUREMENT:MEAS<x>:SOURCE1:WFM command.

You can set numerous measurement parameters that can enhance your measurement results and increase measurement repeatability, please refer to the Measurement Command Group for more information.

Group

Measurement

Syntax 1

MEASUREMENT:MEAS<x>:TYPE {UNDEFINED|HIGH|LOW|AMPLITUDE
|MEAN|MAXIMUM|MINIMUM|PK2PK|MID|POVERSHOOT
|NOVERSHOOT|RMSNOISE|PKPKNOISE|AOPTPWRDBM
|RMS|ACRMS|CRMS|CMEAN|SNRATIO|AOPTPWR|GAIN
|RISE|FALL|PERIOD|FREQUENCY|PCROSS|NCROSS|PWIDTH
|NWIDTH|PDUTY|NDUTY|BURST|RMSJITTER|PKPKJITTER
|DELAY|PHASE|AREA|CAREA|EXTINCTDB|EXTINCTPCT
|EXTINCTRATIO|EYEHEIGHT|PCTCROSS|LEVCROSS|QFACTOR
|EYEWIDTH|DISTDUTY|BITTIME|BITRATE|TIMCROSS
|EYEOFACOR|SUPRSDB|SUPRSPCT|SUPRSRATIO|PULSESym}

Syntax 2

MEASUrement:MEAS<x>:TYPE?

Arguments

Brief definitions of each measurement type follow. For a more comprehensive definition of a measurement type, based on the signal type of the measurement source, select Measurement Reference from the instrument Help menu.

For information on restricting a measurement to an area you specify, see the MEASUrement:MEAS<x>:GATing:STATE command.

- UNDEFined
Use this argument to delete any measurement defined for Meas<x>, freeing it for use.
- HIGH
Use this measurement to measure the top (or Logic 1) reference level of the waveform.
- LOW
Use this argument to measure the bottom (or Logic 0) level of the waveform.
- AMPLitude
Use this argument to measure the difference between the High and Low level of the waveform.
- MEAN
Use this argument to measure the arithmetic mean of the waveform within the measurement region.
- MAXimum
Use this argument to measure the largest amplitude of the waveform within the measurement region.
- MINimum
Use this argument to measure the smallest amplitude of the waveform within the measurement region. It is measured over the entire waveform or gated region.
- PK2Pk
Use this argument to measure the maximum amplitude divergence within the measurement region.
- MID
Use this argument to measure the midpoint of the maximum amplitude divergence within the measurement region. The value is measured over the entire waveform or gated region.
- POVershoot
Use this argument to measure the percentage by which the maximum amplitude of the waveform exceeds the High level.
- NOVershoot

Use this argument to measure the Percentage by which the minimum amplitude of the waveform under-runs the Low level.

- RMSNoise

Use this argument to measure one standard deviation of the waveform amplitude variance. This measurement is taken within the eye aperture for NRZ and RZ waveforms or the center of the measurement region for Pulse waveforms.

- PKPKNoise

Use this argument to measure the maximum range of the waveform amplitude variance measured within either the eye aperture (for NRZ and RZ waveforms) or the center of the measurement region (Pulse waveforms).

- AOPTPWRDBM

Use this argument to measure the true average power of an optical signal expressed in decibels referenced to 1 mw.

- RMS

Use this argument to measure the true root mean square of the waveform within the measurement region.

- ACRMs

Use this argument to measure the root mean square, minus the DC component, of the waveform within the measurement region.

- CRMs

Use this argument to measure the root-mean-square voltage of the waveform within the first period of the measurement region.

- CMEan

Use this argument to measure the arithmetic mean of the waveform over the first cycle of the measurement region.

- SNRatio

Use this argument to measure the ratio of the amplitude of the signal to the noise within either the eye aperture (for NRZ and RZ waveforms) or the center of the measurement region (Pulse waveforms).

- AOPTpwr

Use this argument to measure the True average power of an optical signal expressed in watts.

- GAIN

Use this argument to measure the amplitude gain between two waveforms.

- RISE

Use this argument to measure the time interval between the waveform crossing the low-reference and high-reference levels on a rising edge.

- FALL
Use this argument to measure the time interval between the waveform crossing the high-reference and low-reference levels on a falling edge.
- PERIod
Use this argument to measure the time interval between two consecutive crossings on the same slope of the waveform at the mid-reference level.
- FREQuency
Use this argument to measure the reciprocal of the Period of the waveform.
- PCROss
Use this argument to measure the time at which the waveform crosses the mid-reference level on a rising edge.
- NCROss
Use this argument to measure the time at which the waveform crosses the mid-reference level on a falling edge.
- PWidth
Use this argument to measure the time interval between consecutive rising and falling edges, measured at the mid-reference level.
- NWidth
Use this argument to measure the time interval between consecutive falling and rising edges, measured at the mid-reference level.
- PDUty
Use this argument to measure the percentage of the waveform's +Width relative to its Period or Bit Time.
- NDUty
Use this argument to measure the percentage of the waveform's -Width relative to its Period or Bit Time.
- BURst
Use this argument to measure the time between the first and last crossings, either positive or negative, of the waveform at the mid-reference level within the measurement region.
- RMSJitter
Use this argument to measure the one standard deviation (σ) of the time variance where the waveform crosses the mid-reference level.
- PKPKJitter
Use this argument to measure the delta between the minimum and maximum of time crossings at the mid-reference level.
- DELay
Use this argument to measure the time interval between the crossings of the mid-reference levels on the two sources of the measurement.

- PHAsE
Use this argument to measure the Amount of lead or lag of one measurement source relative to a second measurement source. Phase is expressed in degrees, where 360° comprise one cycle or one bit of the waveform.
- AREa
Use this argument to measure the area under the waveform curve within the measurement region.
- CAREa
Use this argument to measure the area under the curve for the first bit or period of the waveform.
- EXTINGTDB
Use this argument to measure the ratio of logic 1 to logic 0 expressed in decibels (dB).
- EXTINGTPTCT
Use this argument to measure the ratio of logic 0 to logic 1 expressed in percentage (%).
- EXTINGTRATIO
Use this argument to measure the ratio of logic 1 to logic 0 expressed as a simple ratio.
- EYEHeight
Use this argument to measure the horizontal eye opening of the waveform guard-banded by $\pm 3\sigma$, measured over the eye aperture.
- PCTCROSS
Use this argument to measure the height of eye crossing as a percentage of eye height measured in the eye aperture.
- LEVCROSS
Use this argument to measure the mean waveform amplitude at the eye crossing.
- QFACTOR
Use this argument to measure the ratio of the amplitude of the eye to the total RMS noise on the High and Low levels.
- EYEWIdth
Use this argument to measure the horizontal eye opening of the waveform guard-banded by $\pm 3\sigma$, measured at the mid-reference level.
- DISTDUty
Use this argument to measure the ratio of the time interval between the points where the rising and the falling edges cross the mid-reference level and the bit time of the waveform.
- BITTime
Use this argument to measure the time interval between the start of

two successive data bits of the waveform.

- **BITRate**
Use this argument to measure the inverse of the time interval between the start of two successive data bits of the waveform.
- **TIMCROss**
Use this argument to measure the horizontal position (measured from the trigger point) of the eye crossing.
- **EYEOfactor**
Use this argument to measure the horizontal eye opening of the waveform guard-banded by $\pm 1\sigma$, measured over the eye aperture.
- **SUPRSDB**
Use this argument to measure the ratio of the average High level to the suppressed level measured between two consecutive RZ pulses expressed in decibels (dB).
- **SUPRSPCT**
Click this button to measure the Ratio of the average High level to the Suppressed level measured between two consecutive RZ pulses expressed in percentage (%).
- **SUPRSRATIO**
Use this argument to measure the Ratio of the average High level to the Suppressed level measured between two consecutive RZ pulses expressed as a simple ratio.
- **PULSESym**
Use this argument to measure the extent to which the RZ pulse is symmetrical around the peak at the mid-reference level. The pulse peak is the center of the interval, sized to Eye Aperture, which yields the maximum mean vertical value.

Example 1

```
MEASUrement:MEAS3:TYPE FREQuency
```

This command defines Measurement 3 as a measurement of the frequency of a waveform.

Example 2

```
MEASUrement:MEAS3:TYPE?
```

This query might return `:MEASUREMENT:MEAS3:TYPE RMS`, indicating that Measurement 3 is defined to measure the RMS value of a waveform.

MEASUrement:MEAS<x>:UNITS?

This query only command returns the units for the measurement slot specified by x, which can be 1 through 8. You first must have defined the measurement slot using the `MEASUrement:MEAS<x>:TYPE` command before the units can be returned.

Group

Measurement

Related Commands

MEASUREMENT:MEAS<x>:VALUE?, MEASUREMENT:MEAS<x>:TYPE

Syntax

MEASUREMENT:MEAS<x>:UNITS?

Return Values

<QString>

- "dB" for extinction ratio dB
- "Hz" for hertz
- "s" for seconds
- "unitless" for Q-factor
- "V" for volts
- "VV" for volts²
- "volt-seconds" for cycle area
- "W" for watts (used with optical modules)
- "watt-seconds" for cycle area
- "%" for percent
- "Ω" for ohms (used with TDR)
- "Ω-seconds" for cycle area
- "ρ" for rho (used with TDR)
- "ρ-seconds" for cycle area

Example

MEASUREMENT:MEAS3:UNITS?

This query might return :MEASUREMENT:MEAS3:UNITS "%", indicating the units for Measurement 3 are percent.

MEASUREMENT:MEAS<x>:VALUE?

This query only command returns the value that has been calculated for the measurement slot specified by x.

Group

Measurement

Related Commands

MEASUREMENT:MEAS<x>:TYPE, MEASUREMENT:MEAS<x>:UNITS?

Syntax

MEASUREMENT:MEAS<x>:VALUE?

Returns

NR3

This is the calculated value for the specified measurement.

Example

MEASUREMENT:MEAS1:VALUE?

This query might return :MEASUREMENT:MEAS1:VALUE

1.24896277383E+008 as the calculated value for Measurement 1.

MEASUREMENT:STATISTICS:ENABLE

This command sets or queries whether the instrument calculates the measurement statistics. Sending this command is equivalent to selecting the Statistics check box in the Measurement Setup dialog box.

Use the MEASUREMENT:STATISTICS:WEIGHTING command to set statistics weighting. Weighting is the number of measurements over which you want the statistics calculated.

Use the MEASUREMENT:MEAS<x>:ALL? Command to query all the measurement statistical values at one time.

Group

Measurement

Related Commands

MEASUREMENT:STATISTICS:WEIGHTING

MEASUREMENT:MEAS<x>:ALL?

Syntax 1

MEASUREMENT:STATISTICS:ENABLE {ON|OFF|NR1}

Syntax 2

MEASUREMENT:STATISTICS:ENABLE?

Arguments

- ON
This argument causes the instrument to compute the statistics on measurement values. If a measurement is using a waveform database, it will not compute statistics.
- OFF
This argument turns off the calculation of the measurement statistics.
- NR1
A 0 disables the calculation of statistics; any other value enables the calculation of statistics.

Example 1

MEASUREMENT:STATISTICS:ENABLE ON

This command enables the calculation of the measurement statistics.

Example 2

```
MEASUrement:STATIstics:ENABle?
```

This query might return `:MEASUREMENT:STATISTICS:ENABLE 0`, indicating that the calculation of statistics is disabled.

NOTE: A query always returns a 0 or 1.

MEASUrement:STATIstics:WEIGHTing

This command sets or queries the weighting the instrument uses to calculate the measurement statistics. Weighting is the number of measurements over which you want the statistics calculated. Sending this command is equivalent to entering a value in the Weighting control in the Measurements Setup dialog box. The Statistics check box must be selected before the Weighting control is active.

Use the `MEASUrement:STATIstics:ENABle` command to enable the statistics weighting function.

Group

Measurement

Related Commands

```
MEASUrement:STATIstics:ENABle
```

Syntax 1

```
MEASUrement:STATIstics:WEIGHTing <NR1>
```

Syntax 2

```
MEASUrement:STATIstics:WEIGHTing?
```

Argument

NR1

This argument is the number of measurements over which the statistics are calculated. The range is from 2 through 1,000,000 with a resolution of 1. The default value is 32.

Example 1

```
MEASUrement:STATIstics:WEIGHTing 10
```

This command sets the weighting to 10, which means the statistics are calculated over 10 measurements.

Example 2

```
MEASUrement:STATIstics:WEIGHTing?
```

This query might return

```
:MEASUREMENT:STATISTICS:WEIGHTING 50
```

, indicating that the statistics are calculated over 50 measurements.

MEASUrement?

This is a query only command that returns all measurement parameters.

Group

Measurement

Syntax

MEASUREMENT?

Example

MEASUREMENT?

This query might return the following (partial list):

```
:MEASUREMENT:ALL:VALUE 9.91000000000E+037,
9.91000000000E+037,9.91000000000E+037,
9.91000000000E+037,9.91000000000E+037,
9.91000000000E+037,9.91000000000E+037,
9.91000000000E+037;:MEASUREMENT:LIST 1;
LISTVALUE 9.91000000000E+037;ANNOTATIONS:STATE 0;
:MEASUREMENT:STATISTICS:ENABLE 0;WEIGHTING 32;
:MEASUREMENT:MEAS1:NOISE HIGH;JITTER EYECROSS;
EYEWINDOW 20;MAXIMUM 9.91000000000E+037;
MINIMUM 9.91000000000E+037;MEAN 9.91000000000E+037;
STDDEV 9.91000000000E+037;VALUE 9.91000000000E+037;
ALL 9.91000000000E+037,9.91000000000E+037,
9.91000000000E+037,9.91000000000E+037,
9.91000000000E+037;UNITS "";TYPE UNDEFINED;STATE 0;
GATING:STATE 0;:MEASUREMENT:MEAS1:SOURCE1:WFM CH3,
MAIN;WFMDB:STATE 0;SIGTYPE PULSE;:MEASUREMENT:MEAS1
:SOURCE1:GATE1:POS 1.80000000000E-008;...
```

RECALL:SETUP

This command (no query form) restores a stored or factory default setup from a Windows file. Sending this command is equivalent to selecting Recall Saved Setup or Recall Factory Setup in the Save/Recall Setup menu.

Group

Save and Recall

Related Commands

FACTORY, *RST, SAVE:SETUP

Syntax

```
RECALL:SETUP {FACTORY|<file path>}
```

Arguments

- FACTORY
Selects the factory setup.
- <file path>

This is the location from which the setup will be recalled.

The <file path> is a quoted string that defines the file name and path. Input the file path using the form <drive>\<dir>\<filename>. <drive> and one or more <dir>s are optional. If you do not specify them, the instrument will read the file from the default directory. The <filename> can be a Windows 95/Windows 98 long file name. Do not use wild card characters.

Example 1

```
RECALL:SETUP FACTORY
```

Recalls (and makes current) the instrument setup to its factory defaults.

Example 2

```
RECALL:SETUP "TEK00000.STP"
```

Recalls the instrument setup from the file TEK00000.STP in the default directory and on the default drive.

RECALL:WAVEform

This command (no query form) recalls a stored waveform into a reference location. Sending this command is equivalent to selecting Recall Waveform from the File Menu, and then selecting a waveform file source and reference destination in the Recall Waveform dialog box.

Group

Save and Recall

Syntax

```
RECALL:WAVEform <file path>,REF<x>
```

Arguments

- <filepath>
This is a quoted string that defines the file name and path. Input the file path using the form <drive>/<dir>/<filename>. <drive> and one or more <dir>s are optional. If you do not specify them, the instrument will recall the waveform from the default directory. The <filename> can be a Windows 95/Windows 98 long file name. Do not use wild card characters.
- REF<x>
This is the location in internal reference memory to which the waveform is recalled.

Example

```
RECALL:WAVEFORM "TEK00000.WFM",REF1
```

Recalls the waveform stored in the file named TEK00000.WFM in the default directory and on the default drive to Reference waveform 1.

REF<x>:POSition

This command allows you to set or query the vertical position of the specified reference waveform. The reference waveform is specified by x, which can be 1 through 8. This is the equivalent to specifying a reference waveform in the Waveform section of the Vertical Setup dialog box and then entering a value for Position in the Setup section.

Group

Vertical

Syntax 1

```
REF<x>:POSition <NR3>
```

Syntax 2

REF<x>:POSition?

Argument

NR3

This is the desired position, in divisions from the center graticule. The range is ± 1000 divisions.

Example 1

REF2:POSition 1.3E+000

This command positions the Reference 2 waveform 1.3 divisions above the center of the display.

Example 2

REF1:POSition?

This query might return :REF1:POSITION 2.000000000000 as the position setting for the Reference 1 waveform, indicating that the waveform is positioned 2 divisions above the center of the display.

REF<x>:SCALE

This command allows you to set or query the vertical scale of the specified reference waveform. The waveform is specified by x, which can be 1 through 8. This is the equivalent to specifying a reference waveform in the Waveform section of the Vertical Setup dialog box and then entering a value for Scale in the Setup section.

Increasing the Scale causes the waveform to be displayed smaller. Decreasing the scale causes the waveform to be displayed larger. For reference waveforms, this setting controls the display only, graphically scaling these waveforms and having no effect on the acquisition hardware.

Group

Vertical

Syntax 1

REF<x>:SCALE <NR3>

Syntax 2

REF<x>:SCALE?

Argument

NR3

This is the vertical reference scale in units per division.

Example 1

REF4:SCALE 1.0E-02

This command sets the Reference 4 waveform scale to 10 mV per division.

Example 2

REF1:SCALE?

This query might return `:REF1:SCALE 0.100000000000` as the scale setting for the Reference 1 waveform, indicating that the current volts per division setting of the Reference 1 waveform is 100 mV per division.

REF<x>:WFMLabel

This command sets or queries the label associated with the reference waveform specified.

Group

Vertical

Related Commands

CH<x>:WFMLabel, MATH<x>:WFMLabel

Syntax 1

REF<x>:WFMLabel

Syntax2

REF<x>:WFMLabel?

Argument

Qstring

This argument sets the label for the reference waveform.

Example 1

```
REF1:WFMLabel "My REF1 waveform"
```

This command sets the label for REF1 to be "My REF1 waveform," which is the label displayed with the waveform when it is displayed on screen.

Example 2

```
REF1:WFMLabel?
```

This query might return `:REF1:WFMLABEL "My REF1 waveform,"` indicating that the label for the REF1 waveform is set to "My REF1 waveform."

SAVe:SETUp

This command (no query form) saves the current instrument setup into the specified memory location. Sending this is equivalent to selecting Save Setup in the File menu.

Group

Save and Recall

Related Commands

FACTory, RECALL:SETUp

Syntax

SAVe:SETUp <file path>

Arguments

file path

This argument is a quoted string that defines the file name and path. Input the file path using the form <drive>/<dir>/<filename>. <drive> and one or more <dir>s are optional. If you do not specify them, the instrument will write the file to the current directory. The <filename> can be a Windows 95/Windows 98 long file name. Do not use wild card characters. It is recommended that you use "STP" for the extension to identify files that store setup data.

Settings saved in one instrument may or may not work on a different instrument with a different version of firmware.

Example

```
SAVE:SETUP "C:\MY
Documents\Tests\Ui\Data\Setuptest.STP"
```

This command saves the current instrument setup to the file Setuptest.STP in the Data subdirectory on the C drive.

SAVE:WAVEform

This command (no query form) stores a waveform in one of eight reference memory locations or to a file. You must specify a waveform, a timebase, and a destination (either a file path or a waveform reference slot). Sending this command is equivalent to selecting Save Waveform... from the File menu and then selecting a waveform and destination in the Save Waveform(s) dialog box.

Group

Save and Recall

Related Command

DELEte:WAVEform

Syntax

```
SAVE:WAVEform {CH<x>|MATH<x>|REF<x>},
{MAIn|MAG1|MAG2}, {REF<x>|<filepath>}
```

Arguments

- CH<x>
This argument selects a channel waveform to save. The range for x is 1 through 8.
- MATH<x>
This argument selects a math waveform to save. The range for x is 1 through 8.
- REF<x>
This argument selects a reference waveform to save. The range for x is 1 through 8. You can also use this argument as a destination into which a waveform (including a reference waveform) can be saved.
- MAIn
This argument selects Main as the timebase for the saved waveform.

This is the default timebase.

- MAG1

This argument selects MAG1 as the timebase for the saved waveform.

- MAG2

This argument selects MAG2 as the timebase for the saved waveform.

- <file path>

This is the location to which the waveform will be saved.

The <file path> is a quoted string that defines the file name and path. Input the file path using the form <drive>/<dir>/<filename>. The <filename> can be a Windows 95/Windows 98 long file name. Do not use wild card characters.

Example 1

```
SAVE:WAVEFORM MATH2,MAIn,REF1
```

Saves the Math 2 waveform displayed by the Main timebase in Reference memory location 2.

Example 2

```
SAVE:WAVEFORM MATH1,MAG1,"TEK00000.WFM"
```

Saves the Math1 waveform and timebase to the file TEK00000.WFM in the default directory and on the default drive.

SElect:CH<x>

This command sets or queries whether the specified acquisition waveform is displayed. The waveform is specified by x, which can be 1 through 8. This command is the equivalent to selecting an acquisition waveform and checking the On control in the Waveform section of the Vertical Setup dialog box.

Group

Vertical

Related Commands

SElect:CONTROL

Syntax 1

```
SElect:CH<x> {ON|OFF|NR1}
```

Syntax 2

```
SElect:CH<x>?
```

Argument

- ON

This argument displays the specified acquisition waveform.

- OFF

This argument turns off the display of the specified acquisition

waveform.

- NR1

A 0 turns off the display of the specified acquisition waveform; any other value displays the specified acquisition waveform.

Example 1

```
SElect:CH4 1
```

This command displays the acquisition waveform for Channel 4.

Example 2

```
SElect:CH2?
```

This query might return `:SELECT:CH2 0`, indicating that the display of the Channel 2 acquisition waveform is disabled.

NOTE: A query always returns a 0 or 1.

SElect:CONTROL

This command sets or queries the waveform that is currently affected by the front-panel controls. This is the equivalent to pressing the Vertical CH, MATH, or REF button on the front panel and then pressing a button (1 through 8) to specify a waveform.

When sending this command, you must specify a timebase (MAIN, MAG1, or MAG2). Also, the waveform must be displayed for the command to enable control of it.

Note: You should define a math waveform before turning the waveform on.

Group

Vertical

Related Commands

```
SElect:CH<x>
```

Syntax 1

```
SElect:CONTROL {CH<x>|MATH<x>|REF<x>|NONE},  
{MAIN|MAG1|MAG2}
```

Syntax 2

```
SElect:CONTROL?
```

Arguments

- CH<x>

This argument selects the specified channel waveform as the waveform that is affected by the front-panel controls. The range for x is 1 through 8.

- MATH<x>

This argument selects the specified math waveform as the waveform that is affected by the front-panel controls. The range for x is 1 through 8.

- REF<x>

This argument selects the specified reference waveform as the waveform that is affected by the front-panel controls. The range for x is 1 through 8.

- NONE

This argument causes the instrument to do nothing. When returned in a query, NONE indicates that no waveforms are associated with the front-panel controls.

- MAIn

This argument selects Main as the timebase for the specified waveform.

- MAG1

This argument selects MAG1 as the timebase for the specified waveform.

- MAG2

This argument selects MAG2 as the timebase for the specified waveform.

Example 1

```
SElect:CONTROL CH1,MAIn
```

This command selects the Channel 1 acquisition waveform as the waveform affected by the front-panel controls. This waveform is displayed using the main timebase.

Example 2

```
SElect:CONTROL?
```

This query might return :SELECT:CONTROL MATH5,MAIN, indicating that the Math 5 waveform is currently affected by the front-panel controls and is displayed using the main timebase.

Example 3

```
SElect:CONTROL?
```

This query might return :SELECT:CONTROL NONE,MAIN, indicating that no waveform using the Main timebase is controlled by front-panel controls.

SElect:MATH<x>

This command sets or queries whether the specified math waveform is displayed. The waveform is specified by x, which can be 1 through 8. This command is the equivalent to selecting a math waveform and checking the On control in the Waveform section of the Vertical Setup dialog box.

Group

Vertical

Related Commands

SElect:CONTROL

Syntax 1

SElect:Math<x> {ON|OFF|NR1}

Syntax 2

SElect:Math<x>?

Argument

- ON
This argument displays the specified math waveform.
- OFF
This argument turns off the display of the specified math waveform.
- NR1
A 0 turns off the display of the specified math waveform; any other value displays the specified math waveform.

Example 1

SElect:MATH4 1

This command displays the Math 4 waveform.

Example 2

SElect:MATH2?

This query might return :SELECT:MATH2 0, indicating that the display of the Math 2 waveform is disabled.

NOTE: A query always returns a 0 or 1.

SElect:REF<x>

This command sets or queries whether the specified reference waveform is displayed. The waveform is specified by x, which can be 1 through 8. This command is the equivalent to selecting a reference waveform and checking the On control in the Waveform section of the Vertical Setup dialog box.

Note: You should define a reference waveform before turning the waveform on.

Group

Vertical

Related Commands

SElect:CONTROL

Syntax 1

SElect:REF<x> {ON|OFF|NR1}

Syntax 2

SElect:REF<x>?

Argument

- ON
This argument displays the specified reference waveform.

- OFF
This argument turns off the display of the specified reference waveform.
- NR1
A 0 turns off the display of the specified reference waveform; any other value displays the specified reference waveform.

Example 1

```
SElect:REF4 1
```

This command displays the Reference 4 waveform.

Example 2

```
SElect:REF5?
```

This query might return `:SELECT:REF5 0`, indicating that the display of the Reference 5 waveform is disabled.

NOTE: A query always returns a 0 or 1.

SElect?

This is a query only command that returns the selected waveform that is affected by the front-panel controls and the display status (on or off) of all waveforms.

Group

Vertical

Syntax

```
SElect?
```

Example

```
SELECT?
```

This command might return the following:

```
:SELECT:CH1 0;CH2 0;CH3 1;CH4 0;CH5 0;CH6 0;CH7 0;CH8  
0;MATH1 1;MATH2 0;MATH3 0;MATH4 0;MATH5 0;MATH6  
0;MATH7 0;MATH8 0;REF1 1;REF2 0;REF3 0;REF4 0;REF5  
0;REF6 0;REF7 0;REF8 0;CONTROL REF1,MAIN
```

SET?

This query only command returns a string listing the instrument settings, except for configuration information for the calibration values. You can use this string to return the instrument to the state it was in when you made the SET? query. This command is identical to the *LRN? command.

Group

Miscellaneous

Related Commands

HEADer, *LRN?, VERBose

Syntax

SET?

Note: The SET? query always returns a string with command headers, regardless of the setting of the HEADER command. This is because the returned string is intended to be sent back to the instrument as a command string. The VERbose command can still be used to specify whether the returned headers should be abbreviated or full length.

Example

SET?

This query may return a string (partial) that looks like this:

```
:ACQUIRE:MODE SAMPLE;NUMAVG 16;SAVEFILE:SAVESCREEN
";SAVEWFM " ";:ACQUIRE:STATE 1;STOPAFTER:MODE
RUNSTOP;BELL 0;ACTION NONE;CONDITION ACQWFMS;COUNT
1;:CALIBRATE:DCCALIBRATOR 0.0000;:DIAG:LOOP
1;CONTROL:LOOP 0;HALT 0;:CURSOR:CURSOR1:COLOR 5;SOURCE
CH1,MAIN;:CURSOR:CURSOR2:COLOR 5;SOURCE
CH1,MAIN;:CURSOR:DIV2 0;FUNCTION OFF;SELECT
CURSOR1;HBARS:POSITION1 -0.00162162000;POSITION2
0.00170271000;:CURSOR:VBARS:POSITION1 1.67800000000E-
6;POSITION2 3.32800000000E-6;
:CURSOR:WAVEFORM:POSITION1 1.67800000000E-6;
POSITION2 3.32800000000E-6;:DATA:DESTINATION
REF1;SOURCE CH1;ENCDG ASCII;START 1;STOP
500;:WFMINPRE:ENCDG ASCII;BN_FMT RI;BYT_OR LSB;NR_PT
500;PT_FMT Y;XINCR 0.0000;XZERO 16.00000000000E-
9;XUNIT " ";YMULT 0.10000000000;XMULT 100.00000000000E-
12;XOFF 16.00000000000E-9;YZERO 0.0000;YSCALE
0.0000;YOFF 0;...
```

SOURCE<x>

Note that this argument specifies the source, which can be source 1 or source 2. To set the actual waveform (channel, reference, or math) that is assigned to source, you must use the MEASUREMENT:MEAS<x>:SOURCE<x>:WFM command. Two sources are provided because some measurements (gain, phase) require two sources.

SYNC:TIMEOUT

This command sets or queries the default synchronization timeout for commands that rely upon data production by the instrument. The default timeout value of 2 seconds is appropriate for most applications, but you might need to adjust this timeout under the following circumstances:

- Slow waveform acquisition rate. The combination of record-length, averaging, frame-scan, trigger hold-off and trigger-source repetitive-rate settings can result in a waveform acquisition time that exceeds the synchronization timeout. If this is the case, sending a query to the instrument results in a synchronization timeout before the instrument can produce results.

- Custom user configurations. Any configuration that significantly influences the rate at which the instrument produces results can result in a synchronization timeout. Such configurations can include any third-party software that you install if it consumes a significant amount of CPU cycles or system resources.

Group

Miscellaneous

Related Commands

```
:MEASUrement:ALL:VALue?, :MEASUrement:LIST?,
:MEASUrement:LISTValue?, :MEASUrement:MEAS<X>:MAXimum?,
:MEASUrement:MEAS<X>:MINimum?,
:MEASUrement:MEAS<X>:MEAN?,
:MEASUrement:MEAS<X>:STDdev?,
:MEASUrement:MEAS<X>:VALue?,
:MEASUrement:MEAS<X>:ALL?,
:MEASUrement:MEAS<X>:UNIts?,
:MEASUrement:MEAS<X>:TYPE?,
:ACQuire:CURRentcount:ACQWfms?,
:ACQuire:CURRentcount:HISTWfms?,
:ACQuire:CURRentcount:HISTHits?,
:ACQuire:CURRentcount:MASKWfms?,
:ACQuire:CURRentcount:MASKSamples?,
:ACQuire:CURRentcount:MASKTHits?,
:ACQuire:CURRentcount:MASKHits<X>?,
:MASK:COUNT:TOTal?, :MASK:COUNT:WAVEforms?,
:MASK:COUNT:SAMPLES?, :MASK:MASK<X>:COUNT?,
:HISTogram:STATistics?, :HISTogram:MEAN?, :HISTogram:MEDIAN?,
:HISTogram:STDdev?, :HISTogram:PKTOPK?,
:HISTogram:SIGMA<Y>?, :HISTogram:PEAKHits?, :HISTogram:HITS?,
:HISTogram:WAVEforms?
```

Syntax 1

```
SYNC:TIMEOUT <NR1>
```

Syntax 2

```
SYNC:TIMEOUT?
```

Arguments

NR1

The desired timeout duration specified in seconds. When any of the related commands are issued to the instrument, if query results are not produced before the timeout expires, a timeout condition will occur. Typically, this will result in error event being posted to the Event Queue and will be reflected in the Standard Event Status Register (SESR). For a more detailed discussion of error reporting, please refer to the Status and Events section.

Example 1

`SYNC:TIMEOUT 10`

This command adjusts the synchronization timeout to a duration of 10 seconds.

Example 2

`SYNC:TIMEOUT?`

This query might return `2`, indicating the default timeout is 2 seconds.

SYSTem:PROPERTIES:ACQHWver?

This query only command returns the hardware version of the Acquisition circuit board in the instrument.

Group

System

Syntax

`SYSTem:PROPERTIES:ACQHWver?`

Example

`SYSTem:PROPERTIES:ACQHWver?`

This query might return `:SYSTEM:PROPERTIES:ACQHWVER 1`.

SYSTem:PROPERTIES:CH<x>:BANDwidth?

This query only command returns a list of available bandwidth selections or, if applicable to the sampling module channel, its characteristic bandwidth.

Group

System

Related Commands

`CH<x>:BANDwidth:LIST?`, `CH<x>:BANDwidth:VALue`

Syntax

`SYSTem:PROPERTIES:CH<x>:BANDwidth?`

Example 1

`SYSTem:PROPERTIES:CH1:BANDwidth?`

This query might return `:SYSTEM:PROPERTIES:CH1:BANDWIDTH 2.000000000000E+010,1.24999997440E+010`, indicating that the available bandwidths for Channel 1 are 20 GHz and 12.5 GHz.

Example 2

`SYSTem:PROPERTIES:CH5:BANDwidth?`

This query might return `:SYSTEM:PROPERTIES:CH5:BANDWIDTH 5.000000000000E+010`, indicating that the characteristic bandwidth of the sampling module is 50 GHz.

SYStem:PROPERTIES:CH<x>:CAPacitance?

This query only command returns the characteristic load capacitance (if applicable) of the channel specified by x, which can be 1 through 8.

Group

System

Syntax

SYStem:PROPERTIES:CH<x>:CAPacitance?

Example

SYStem:PROPERTIES:CH3:CAPacitance?

This query might return

:SYSTEM:PROPERTIES:CH3:CAPACITANCE

4.75000000000E-013, indicating that the characteristic load capacitance for Channel 3 is 0.475 pF.

SYStem:PROPERTIES:CH<x>:CLKRec?

This query only command returns a list of the available clock recovery selections available to the trigger system from the channel specified by x, which can be 1 through 8.

Group

System

Related Commands

TRIGger:CH<x>:CLKRec:LIST?, TRIGger:CH<x>:CLKRec:VALue,
TRIGger:CLKRec:SOUrce

Syntax

SYStem:PROPERTIES:CH<x>:CLKRec?

Example

SYStem:PROPERTIES:CH1:CLKRec?

This query might return :SYSTEM:PROPERTIES:CH1:CLKREC
NONE, OC12, OC48.

SYStem:PROPERTIES:CH<x>:DYNamic?

This query only command returns the lower (minimum) and upper (maximum) input signal dynamic limits of the specified channel of the sampling module. The channel is specified by x, which can be 1 through 8.

Group

System

Syntax

SYStem:PROPERTIES:CH<x>:DYNamic?

Example

SYStem:PROPERTIES:CH5:DYNamic?

This query might return :SYSTEM:PROPERTIES:CH5:DYNAMIC -5.00000000000E-001,5.00000000000E-001, indicating that the input dynamic range of Channel 5 is between -0.5 to +0.5, for a total dynamic range of 1.0 (with the applicable unit of measurement determined by the type of sampling module for the channel).

SYStem:PROPERTIES:CH<x>:EXTender?

This query only command returns the extender cable type that is attached to the channel specified by x, which can be 1 through 8. The extender attaches between the sampling module and the mainframe.

Group

System

Syntax

SYStem:PROPERTIES:CH<x>:EXTender?

Example

SYStem:PROPERTIES:CH8:EXTender?

This query might return :SYSTEM:PROPERTIES:CH8:EXTENDER ONEMETER, indicating that a 1-meter extender cable is present on Channel 8.

SYStem:PROPERTIES:CH<x>:FILTer?

This query only command returns a list of the available filter selections for the channel specified by x, which can be 1 through 8.

Group

System

Related Commands

CH<x>:FILTer:LIST?, CH<x>:FILTer:VALue

Syntax

SYStem:PROPERTIES:CH<x>:FILTer?

Example

SYStem:PROPERTIES:CH1:FILTer?

This query might return :SYSTEM:PROPERTIES:CH1:FILTER NONE,OC12,OC48,OC192.

SYStem:PROPERTIES:CH<x>:IMPedance?

This query only command returns the characteristic input impedance of the sampling module (if applicable) for the channel specified by x, which can be 1 through 8.

Group

System

Syntax

SYSTem:PROPErties:CH<x>:IMPedance?

Example

SYSTem:PROPErties:CH3:IMPedance?

This query might return :SYSTEM:PROPERTIES:CH3:IMPEDANCE
5.00000000000E+001, indicating that the characteristic input
impedance is 50 Ω for Channel 3.

SYSTem:PROPErties:CH<X>:MODElnum?

This query only command returns the sampling module model number of
the specified channel.

Group

System

Syntax

SYSTem:PROPErties:CH<x>:MODElnum?

Returns

Example

SYSTem:PROPErties:CH4:MODElnum?

This query might return :SYSTEM:PROPERTIES:CH4:MODELNUM
"80E04".

SYSTem:PROPErties:CH<x>:NONDEstruct?

This query only command returns the lower (minimum) and upper
(maximum) absolute input signal nondestructive limits of the channel
specified by x, which can be 1 through 8.

Group

System

Syntax

SYSTem:PROPErties:CH<x>:NONDEstruct?

Example

SYSTem:PROPErties:CH3:NONDEstruct?

This query might return :SYSTEM:PROPERTIES:CH3
:NONDESTRUCT -
3.00000000000E+000, 3.00000000000E+000, indicating that
the absolute input nondestruct range for Channel 3 is from -3.0 to +3.0
(with the applicable unit of measure determined by the type of sampling
module for the channel).

SYSTem:PROPErties:CH<x>:OPERating?

This query only command returns the lower (minimum) and upper
(maximum) absolute input signal operating limits of the sampling
module channel specified by x, which can be 1 through 8.

Group

System

Syntax

SYSTem:PROPerties:CH<x>:OPERating?

Example

SYSTem:PROPerties:CH5:OPERating?

This query might return :SYSTEM:PROPERTIES:CH3:OPERATING -1.600000000000E+000,1.600000000000E+000, indicating that the absolute input operating range for CH5 is from -1.6 to +1.6 (with the applicable unit of measure determined by the type of sampling module for the channel).

SYSTem:PROPerties:CH<x>:PRObe:DYNamic?

This query only command returns the lower (minimum) and upper (maximum) output signal dynamic limits of a probe attached to the channel specified by x, which can be 1 through 8. The actual input dynamic range of the probe (and channel) can be calculated by dividing the dynamic range limits of the probe by the scale factor of the probe.

Group

System

Related Commands

SYSTem:PROPerties:CH<x>:PRObe:SCALE?

Syntax

SYSTem:PROPerties:CH6:PRObe:DYNamic?

Example

SYSTem:PROPerties:CH3:PRObe:DYNamic?

This query might return :SYSTEM:PROPERTIES:CH3:PROBE :DYNAMIC -4.000000000000E-001,4.000000000000E-001, indicating that the output dynamic range of the probe attached to Channel 3 is -4.0 to +4.0 (with the applicable unit of measure determined by the type of probe and sampling module for the channel).

SYSTem:PROPerties:CH<x>:PRObe:IMPedance?

This query only command returns the characteristic input impedance of a probe attached to the channel specified by x, which can be 1 through 8.

Group

System

Syntax

SYSTem:PROPerties:CH<x>:PRObe:IMPedance?

Example

SYSTem:PROPerties:CH1:PRObe:IMPedance?

This query might return `:SYSTEM:PROPERTIES:CH1:PROBE:IMPEDANCE 1.00000000000E+005`, indicating that the characteristic input impedance of the probe attached to Channel 1 is 100 k Ω .

SYStem:PROPerTies:CH<x>:PRObe:MODElnum?

This query only command returns the model number of the probe attached to the channel specified by x, which can be 1 through 8.

Group

System

Syntax

`SYStem:PROPerTies:CH<x>:PRObe:MODElnum?`

Example

`SYStem:PROPerTies:CH3:PRObe:MODElnum?`

This query might return `:SYSTEM:PROPERTIES:CH3:PROBE:MODELNUM "P6209"`, indicating that a Tektronix P6209 FET probe is attached to Channel 3.

SYStem:PROPerTies:CH<x>:PRObe:SCALE?

This query only command returns the scale factor of a probe attached to the channel specified by x, which can be 1 through 8.

Group

System

Syntax

`SYStem:PROPerTies:CH<x>:PRObe:SCALE?`

Example

`SYStem:PROPerTies:CH3:PRObe:SCALE?`

This query might return `:SYSTEM:PROPERTIES:CH3:PROBE:SCALE 1.00000000000E-001`, indicating that the probe attached to Channel 3 has a probe characteristic scale factor of 0.1 (that is, a 10X attenuation from input to output).

SYStem:PROPerTies:CH<x>:PRObe:SERIalnum?

This query only command returns the serial number of the probe attached to the specified channel.

Group

System

Syntax

`SYStem:PROPerTies:CH<x>:PRObe:SERIalnum?`

Returns

Example

```
SYSTem:PROPerTies:CH3:PRObe:SERialnum?
```

This query might return

```
:SYSTEM:PROPERTIES:CH3:PROBE:SERIALNUM "B012288".
```

SYSTem:PROPerTies:CH<x>:RISetime?

This query only command returns the characteristic risetime of the sampling module (if applicable) for the channel specified by x, which can be 1 through 8.

Group

System

Syntax

```
SYSTem:PROPerTies:CH<x>:RISetime?
```

Example

```
SYSTem:PROPerTies:CH4:RISetime?
```

This query might return :SYSTEM:PROPERTIES:CH4:RISETIME 1.74999997132E-011, indicating that the characteristic risetime for Channel 4 is 17.5 ps.

SYSTem:PROPerTies:CH<x>:SERialnum?

This query only command returns the sampling module serial number of the channel specified by x, which can be 1 through 8.

Group

System

Syntax

```
SYSTem:PROPerTies:CH<X>:SERialnum?
```

Returns

Example

```
SYSTem:PROPerTies:CH4:SERialnum?
```

This query might return :SYSTEM:PROPERTIES:CH4:SERIALNUM "B013456".

SYSTem:PROPerTies:CH<x>:TEKPDriver?

This query only command returns the TEKPROBE driver revision number for the channel specified by x, which can be 1 through 8.

Group

System

Syntax

```
SYSTem:PROPerTies:CH<x>:TEKPDriver?
```

Example

```
SYSTem:PROPerTies:CH4:TEKPDriver?
```

This query might return

```
:SYSTEM:PROPERTIES:CH4:TEKPDRIIVER "1.00",
```

 indicating the TEKPROBE driver revision number for Channel 4.

SYSTem:PROPerTies:CH<x>:TEKPVersion?

This query only command returns the TEKPROBE version number for the channel specified by x, which can be 1 through 8.

Group

System

Syntax

```
SYSTem:PROPerTies:CH<x>:TEKPVersion?
```

Example

```
SYSTem:PROPerTies:CH4:TEKPVersion?
```

This query might return

```
:SYSTEM:PROPERTIES:CH4:TEKPVERSION "3.00",
```

 indicating the TEKPROBE version number for Channel 4.

SYSTem:PROPerTies:CH<x>:WLENGth?

This query only command returns a list of the available factory and user wavelength selections for the channel specified by x, which can be 1 through 8.

Group

System

Related Commands

```
CH<x>:WLENGth:LIST?, CH<x>:WLENGth:VALue
```

Syntax

```
SYSTem:PROPerTies:CH<x>:WLENGth?
```

Example

```
SYSTem:PROPerTies:CH2:WLENGth?
```

This query might return :SYSTEM:PROPERTIES:CH2:WLENGTH
FACTORY,1550,1310,USER,1000.

SYSTem:PROPerTies:GRoup<x>:TEKPVersion?

This query only command returns the version number of the TEKPROBE controller hardware specified by x, which can be 1 or 2.

Group

System

Syntax

```
SYSTem:PROPerTies:GRoup<x>:TEKPVersion?
```

Example

```
SYSTem:PROPerTies:GROup1:TEKPVersion?
```

This query might return :SYSTEM:PROPERTIES:GROUP1:TEKPVERSION "1331-00", indicating the version of the TEKPROBE controller for Group 1.

SYSTem:PROPerTies:MAInframe:MODEInum?

This query only command returns the model number of the mainframe instrument.

Group

System

Syntax

```
SYSTem:PROPerTies:MAInframe:MODEInum?
```

Example

```
SYSTem:PROPerTies:MAInframe:MODEInum?
```

This query might return :SYSTEM:PROPERTIES:MAINFRAME:MODELNUM "CSA8000". Other model numbers that might be returned include "CSA8000B", "TDS8000", and "TDS8000B".

SYSTem:PROPerTies:MAInframe:SERIalnum?

This query only command returns the serial number of the mainframe instrument.

Group

System

Syntax

```
SYSTem:PROPerTies:MAInframe:SERIalnum?
```

Example

```
SYSTem:PROPerTies:MAInframe:SERIalnum?
```

This query might return :SYSTEM:PROPERTIES:MAINFRAME:SERIALNUM "B010247".

SYSTem:PROPerTies:MAInframe:SWVersion?

This query only command returns the software version number of the mainframe instrument.

Group

System

Syntax

```
SYSTem:PROPerTies:MAInframe:SWVersion?
```

Example

```
SYSTem:PROPerTies:MAInframe:SWVersion?
```

This query might return
:SYSTEM:PROPERTIES:MAINFRAME:SWVERSION "1.0.0".

SYSTem:PROPerTies:ONTime?

This query only command returns the on time (in hours) for the current power-on cycle of the instrument.

Group

System

Syntax

SYSTem:PROPerTies:ONTime?

Example

SYSTem:PROPerTies:ONTime?

This query might return :SYSTEM:PROPERTIES:ONTIME 1.50, indicating the on time for the instrument for the current power-on cycle is 1.5 hours.

SYSTem:PROPerTies:POWerups?

This query only command returns the total number of times that the instrument has been powered on.

Group

System

Syntax

SYSTem:PROPerTies:POWerups?

Example

SYSTem:PROPerTies:POWerups?

This query might return :SYSTEM:PROPERTIES:POWERUPS 8, indicating that the instrument has been powered on a total of eight times.

SYSTem:PROPerTies:PROCHWver?

This query only command returns the hardware version of the Processor circuit board in the instrument.

Group

System

Syntax

SYSTem:PROPerTies:PROCHWver?

Example

SYSTem:PROPerTies:PROCHWver?

This query might return :SYSTEM:PROPERTIES:PROCHWVER 1.

SYSTem:PROPerTies:TOTalontime?

This query only command returns the total accumulated power-on time (in hours) across all power cycles.

Group

System

Syntax

```
SYSTem:PROPerTies:TOTalontime?
```

Example

```
SYSTem:PROPerTies:TOTalontime?
```

This query might return :SYSTEM:PROPERTIES:TOTALONTIME 533.47, indicating the total power-on time for the instrument is 533.47 hours.

TDR:CH<x>:PRESET

This command (no query form) sets the instrument to predefined TDR settings for the channel specified by x, which can be 1 through 8.

A TDR preset on any channel makes the following changes:

- Turns on the acquisition and display for the selected channel.
- Turns on the TDR step for the selected channel (of the selected step polarity).
- Sets the vertical scale, offset, and position for the selected channel such that the vertical region corresponding to the front-panel connector is placed approximately at center screen (vertically).
- Sets the horizontal scale and position such that the incident TDR step is on screen.
- Sets the horizontal timebase mode to Lock to Internal 10MHz.
- Sets the trigger source to Internal Clock. The Internal Clock Rate is not changed.

Note: You cannot preset channels that are not TDR capable or that have external accessories attached, such as probes.

If you are using a sampling module extender cable (or multiple extender cables of differing lengths), it is not possible to view incident TDR steps on those channels not attached to the longest cable due to the effect of extender cables on the minimum horizontal position.

Group

TDR

Related Commands

TDR:CH<x>:UNIts, TDR:CH<x>:STEP:POLarity,
TDR:CH<x>:STEP:STATE

Syntax 1

TDR:CH<x>:PRESET

Example 1

TDR:CH3:PRESET

TDR:CH<x>:STEP:DESkew

This command sets or queries the time (deskew) at which the step generator for the even-numbered channel asserts the TDR step relative to the odd-numbered channel of the TDR sampling module. Normally, you do not use deskew with single channels; it is a two-channel adjustment. Channels are selected as pairs to set deskew (for example, Channel 1 and Channel 2, Channel 3 and Channel 4, and so on). You can set the deskew on either channel of the channel pair, and both channels are coerced. The deskew is set as a percentage.

Group

TDR

Syntax 1

TDR:CH<x>:STEP:DESkew <NR3>

Syntax 2

TDR:CH<x>:STEP:DESkew?

Argument

NR3

This argument is the percentage of time at which the step generator for the right channel asserts the TDR step relative to the left channel. The range is -100 to +100% with a resolution of 0.1%.

Example 1

TDR:CH3:STEP:DESkew 1.05+001

This command sets the deskew between Channel 3 and Channel 4 to 10.5%.

Example 2

TDR:CH3:STEP:DESkew?

This query might return :TDR:CH3:STEP:DESkew

30.0000000000, indicating that the deskew for Channel 3 is set to 30%.

TDR:CH<x>:STEP:POLarity

This command sets or queries the polarity (positive- or negative-going) of the TDR output pulses for the specified channel. The channel is specified by x, which can be 1 through 8. This is equivalent to toggling

the polarity icon between a rising edge and a falling edge in the TDR Step section of the TDR Setup dialog box for the specified channel.

Group

TDR

Syntax 1

```
TDR:CH<x>:STEP:POLarity {PLUS|MINUS}
```

Syntax 2

```
TDR:CH<x>:STEP:POLarity?
```

Arguments

- PLUS
This argument sets positive-going TDR output pulses.
- MINUS
This argument sets negative-going TDR output pulses.

Example 1

```
TDR:CH2:STEP:POLarity PLUS
```

This command sets positive-going TDR output pulses for Channel 2.

Example 2

```
TDR:CH3:STEP:POLarity?
```

This query might return :TDR:CH3:STEP:POLARITY MINUS, indicating that negative-going TDR output pulses are set for Channel 3.

TDR:CH<x>:STEP:STATE

This command sets or queries whether the TDR step generator is on or off for the specified channel. The channel is specified by x, which can be 1 through 8. This is equivalent to checking the ON control for the specified channel in the TDR Step section of the TDR Setup dialog box.

Note: You cannot turn on the step generator for a channel that has a probe attached. If the step generator is on and you then attach a probe to the channel, the instrument will turn the step generator off.

Group

TDR

Syntax 1

```
TDR:CH<x>:STEP:STATE {ON|OFF|NR1}
```

Syntax 2

```
TDR:CH[n]:STEP:STATE?
```

Arguments

- ON
This enables the TDR generator for the specified channel.
- OFF
This disables the TDR generator for the specified channel.

- NR1
A 0 disables the TDR step generator for the specified channel; any other value enables the step generator for the specified channel.

Example 1

TDR:CH6:STEP:STATE OFF

This command turns off the TDR generator for Channel 6.

Example 2

TDR:CH5:STEP:STATE?

This query might return :TDR:CH5:STEP:STATE 1, indicating that the TDR generator for Channel 5 is on.

NOTE: A query always returns a 0 or 1.

TDR:CH<x>:UNIts

This command sets or queries the TDR units for the channel specified by x, which can be 1 through 8. This is equivalent to checking the ON control for the specified channel in the TDR Step section of the TDR Setup dialog box and then selecting the units from the pulldown list for the specified channel. The units of measure commonly used in TDR are units of rho (ρ) measured on the vertical axis.

Note: These units apply only when the TDR step is on for the specified channel; when the TDR step is on, the vertical units setting for the specified channel is overwritten.

Group

TDR

Related Commands

TDR:CH<x>:PRESET, CH<x>:UNIts

Syntax 1

TDR:CH<x>:UNIts {Volt|Rho|Ohm}

Syntax 2

TDR:CH<x>:UNIts?

Arguments

- Volt
This argument sets the units for the specified channel to volts.
- Rho
This argument sets the units for the specified channel to rho.
- Ohm
This argument sets the units for the specified channel to ohms.

Example 1

TDR:CH3:UNIts Volt

This command sets the units for Channel 3 to volts.

Example 2

```
TDR:CH3:UNITS?
```

This query might return `:TDR:CH3:UNITS OHM`, indicating that the units for Channel 3 are ohms.

TDR:INTRate

This command sets or queries the TDR (internal clock) rate. The command sets the same parameter as the TRIGger:INTRate command. The internal clock in the instrument generates a continuous signal with selectable repetition rates of 200 kHz (default), 100 kHz, 50 kHz, and 25 kHz. Sending this command is equivalent to selecting a value for Internal Clock in the TDR (or Trigger) Setup dialog box. The internal clock rate is used to synchronize the generation of TDR step pulses with the subsequent acquisition.

Group

TDR

Related Commands

TRIGger:INTRate

Syntax 1

```
TDR:INTRate <NR3>
```

Syntax 2

```
TDR:INTRate?
```

Argument

NR3

This argument sets the internal clock rate to one of the following: 25 kHz, 50 kHz, 100 kHz, or 200 kHz. You can input any NR3 value; the instrument will set the internal clock rate to the closest available setting.

Example 1

```
TDR:INTRate 100E3
```

This command sets the internal clock rate to 100 kHz.

Example 2

```
TDR:INTRate?
```

This query might return `:TDR:INTRATE 0.200000000000E+006`, indicating that the internal clock rate is set to the default, which is 200 kHz.

TDR?

This query only command returns all of the TDR parameters.

Group

TDR

Syntax

```
TDR?
```

Example

TDR?

```
This query might return :TDR:CH1:UNITS RHO;STEP:STATE 0;DESKEW 0.0000000000;POLARITY PLUS;;TDR:CH2:UNITS RHO;STEP:STATE 0;DESKEW 0.0000000000;POLARITY PLUS;;TDR:CH3:UNITS RHO;STEP:STATE 0;DESKEW 10.5000000000;POLARITY MINUS;;TDR:CH4:UNITS OHM;STEP:STATE 1;DESKEW -11.0000000000;POLARITY MINUS;;TDR:CH5:UNITS RHO;STEP:STATE 0;DESKEW 0.0000000000;POLARITY PLUS;;TDR:CH6:UNITS RHO;STEP:STATE 0;DESKEW 0.0000000000;POLARITY PLUS;;TDR:CH7:UNITS RHO;STEP:STATE 0;DESKEW 0.0000000000;POLARITY PLUS;;TDR:CH8:UNITS RHO;STEP:STATE 0;DESKEW 0.0000000000;POLARITY PLUS;;TDR:INTRATE 100.
```

TIME

This command sets or queries the time that the instrument can display.

Group

Miscellaneous

Related Commands

DATE

Syntax 1

```
TIME <QString>
```

Syntax 2

```
TIME?
```

Argument

QString

This is time in the form "hh:mm:ss".

- hh is the hour number from 1 to 24.
- mm is the minute number in the hour from 0 to 59.
- ss is the seconds number in the minute from 0 to 59.

Note: There must be a colon after the hh and after the mm.

Example 1

```
TIME "01:24:00"
```

This command sets the time to 01:24 AM.

Example 2

```
TIME?
```

This query might return :TIME 14:30:00, indicating that the time is 2:30 PM.

TRIGger:CH<x>:CLKRec:LIST?

This query returns a list of the clock recovery selections that are available for the channel specified by x, which can be 1 or 2. The available choices are dependent on the optical sampling module that is installed.

The optical modules have differing valid settings. Use the <>:LIST? query to determine the valid {Clock Recovery | Filter | Bandwidth | Wavelength} settings for your optical module. Features of optical modules are listed in the *80C0X Optical Module User Manual*. Features of currently installed optical modules can be viewed using the System Properties dialog.

Group

Trigger

Syntax

```
TRIGger:CH<x>:CLKRec:LIST?
```

Example

```
TRIGger:CH1:CLKRec:LIST?
```

This query might return :TRIGGER:CH1:CLKREC:LIST
NONE, OC12, OC48.

TRIGger:CH<x>:CLKRec:VALue

This command sets or queries the clock recovery value that is applied to the channel specified by x, which can be 1 or 2. The clock-recovery selections require hardware support that may not be provided by your sampling module; see your 8000-series sampling-module user manual to determine which clock-recovery selections your module supports. You can also use the SYStem:PROPERTIES:CH<x>:CLKRec? query to determine clock recovery options available for the specified channel.

If you select a clock recovery setting that your sampling module does not support, you will receive Execution Error code 220 with error message "Parameter Error." (See *Messages* on page 347 for general information on programming interface messages.)

Group

Trigger

Syntax 1

```
TRIGger:CH<x>:CLKRec:VALue {NONE|OC1|OC3|OC9|OC12  
|OC18|OC24|OC36|OC48|FEC2666|OC96|OC192|FEC10664  
|FEC10709|FC1063|FC2125|FC4250|ENET1250|ENET3125  
|ENET9953|ENET10313  
|INFIband}
```

Syntax 2

```
TRIGger:CH<x>:CLKRec:VALue?
```

Arguments

- NONE

Disables reference-receiver filtering.

- OC1
Selects a reference-receiver filter for the 51.84 Mb/s bit rate, in accordance with the Sonet/SDHOC-1/STM-0 standard.
- OC3
Selects a reference-receiver filter for the 155.52 Mb/s bit rate, in accordance with the Sonet/SDHOC-3/STM-1 standard.
- OC9
Selects a reference-receiver filter for the 466.56 Mb/s bit rate, in accordance with the Sonet/SDHOC-9/STM-3 standard.
- OC12
Selects a reference-receiver filter for the 622.08 Mb/s bit rate, in accordance with the Sonet/SDHOC-12/STM-4 standard.
- OC18
Selects a reference-receiver filter for the 933.12 Mb/s bit rate, in accordance with the Sonet/SDHOC-18/STM-6 standard.
- OC24
Selects a reference-receiver filter for the 1.24416 Gb/s bit rate, in accordance with the Sonet/SDHOC-24/STM-8 standard.
- OC36
Selects a reference-receiver filter for the 1.86624 Gb/s bit rate, in accordance with the Sonet/SDHOC-36/STM-12 standard.
- OC48
Selects a reference-receiver filter for the 2.48832 Gb/s bit rate, in accordance with the Sonet/SDHOC-48/STM-16 standard.
- FEC2666
Selects a reference-receiver filter for the 2.6660571 Gb/s bit rate, in accordance with the ITU-T G.975 Recommendation
- OC96
Selects a reference-receiver filter for the 4.97664 Gb/s bit rate, in accordance with the Sonet/SDHOC96/STM-32 standard.
- OC192
Selects a reference-receiver filter for the 9.95328 Gb/s bit rate, in accordance with the Sonet/SDHOC192/STM-64 standard.
- FEC10664
Selects a reference-receiver filter for the 10.6642 Gb/s bit rate, in accordance with the ITU-T G.975 Recommendation
- FEC10709
Selects a reference-receiver filter for the 10.709225 Gb/s bit rate, in accordance with the ITU-T G.709 Draft Recommendation
- FC1063

Selects a reference-receiver filter for the 1.0625 Gb/s bit rate, in accordance with the ANSI X3.230-1994 standard.

- FC2125
Selects a reference-receiver filter for the 2.125 Gb/s bit rate, in accordance with the ANSI Fibre Channel Physical Interface (FC-PI) Rev 11 draft standard.
- FC4250
Selects a reference-receiver filter for the 4.250 Gb/s bit rate, in accordance with the ANSI Fibre Channel Physical Interface (FC-PI) Rev 11 draft standard.
- ENET1250
Selects a reference-receiver filter for the 1.250 Gb/s bit rate, in accordance with the IEEE 802.3 standard.
- ENET3125
Selects a reference-receiver filter for the 3.125 Gb/s bit rate, in accordance with the IEEE P802.ae draft standard.
- ENET9953
Selects a reference-receiver filter for the 9.9533 Gb/s bit rate, in accordance with the IEEE P802.ae draft standard.
- ENET10313
Selects a reference-receiver filter for the 10.3125 Gb/s bit rate, in accordance with the IEEE P802.ae draft standard.
- INFIband
Selects a reference-receiver filter for the 2.500 Gb/s bit rate, in accordance with the InfiniBand standard.

Example 1

```
TRIGger:CH<x>:CLKRec:VALue OC12
```

This command sets the clock-recovery value for Channel 1 to the OC12 standard.

Example 2

```
TRIGger:CH1:CLKRec:VALue?
```

This query might return : TRIGGER:CH1:CLKREC:VALUE OC48, indicating that the clock-recovery value selected for Channel 1 is the OC48 standard (data rate of 2488.3 Mb/s).

TRIGger:CLKRec:SOURce

This command sets or queries the clock recovery trigger source. The clock recovery trigger source is derived from the optical input of an 80C0x optical module with an installed clock recovery option. This clock is synchronous with the incoming data signal. Use of this trigger source requires an optical sampling module that supports clock recovery. The sampling module picks the clock off internally and outputs it to the instrument for triggering.

Group

Trigger

Syntax 1

```
TRIGger:CLKRec:SOUrce {CH<x>|NONE}
```

Syntax 2

```
TRIGger:CLKRec:SOUrce?
```

Arguments

- CH<x>
This argument is the channel for which you want to set the clock recovery source. The value for x can be 1 or 2.
- NONE
Setting or querying this argument indicates that the specified channel has no available clock recovery options. You cannot set a specified channel to NONE if there are available clock recovery options.

Example 1

```
TRIGger:CLKRec:SOUrce CH2
```

This command sets the source for clock recovery to Channel 2.

Example 2

```
TRIGger:CLKRec:SOUrce?
```

This query might return :TRIGGER:CLKREC:SOURCE CH1, indicating that Channel 1 is the source for clock recovery.

TRIGger:GATEd

This command sets or queries the gated triggering setting, on (enabled) or off (disabled). When enabled, the Trigger Gate (TTL) input at the instrument rear panel qualifies trigger events such that the trigger system ignores trigger events (including auto triggers and external trigger inputs) while the Trigger Gate input remains asserted. See the following table.

Trigger Gate input	TRIGger:GATEd setting	Trigger behavior
LOW (< 0.8 volts)	ON or 1	Trigger events are ignored
HIGH (> 2.0 volts)	ON or 1	Trigger events are handled
LOW (< 0.8 volts)	OFF or 0	Trigger events are handled
HIGH (> 2.0 volts)	OFF or 0	Trigger events are handled

Option GT

Note that this command is only available for CSA8000B or TDS8000B instruments that come with Option GT installed. CSA8000 or TDS8000 instruments cannot use Option GT, even if their product software is upgraded. An instrument not equipped with the GT option returns an error message if sent this command.

Group

Trigger

Related Commands

TRIGger:SOUrce

Syntax 1

TRIGger:GATED {ON|OFF|NR1}

Syntax 2

TRIGger:GATED?

Arguments

- ON
Enables gating of the trigger system.
- OFF
Disables gating of the trigger system.
- NR1
A 0 disables gated triggering; any other value enables it.

Example 1

```
TRIGger:GATED OFF
```

This command disables the gated triggering feature.

Example 2

```
TRIGger:GATED?
```

This query might return `:TRIGGER:GATED 1`, indicating that the gated triggering feature is enabled. If Option GT is not installed, this query always returns 0 and generates the Execution Error code 2509 with error message `Gated Trigger is not Available`.

NOTE: A query always returns a 0 or 1.

TRIGger:HIFreq

This command sets or queries whether the high-frequency triggering function is enabled. The enhanced triggering control increases the trigger sensitivity of the trigger circuit by decreasing hysteresis. This allows triggering on higher frequency signals. This command is equivalent to selecting High Frequency Triggering in the Enhanced Triggering section of the Trigger Setup dialog box. High Frequency Triggering is enabled only when the trigger source is External Direct (see the TRIGger:SOUrce command).

Group

Trigger

Related Commands

TRIGger:SOUrce

Syntax 1

TRIGger:HIFreq {ON|OFF|NR1}

Syntax 2

TRIGger:HIFreq?

Arguments

- ON
Enables high-frequency triggering.
- OFF
Disables high-frequency triggering.
- NR1
A 0 disables the high-frequency triggering; any other value enables the high-frequency triggering.

Example 1

```
TRIGger:HIFreq OFF
```

This command disables the high-frequency triggering.

Example 2

```
TRIGger:HIFreq?
```

This query might return `:TRIGGER:HIFREQ 1`, indicating that the high-frequency triggering is enabled.

NOTE: A query always returns a 0 or 1.

TRIGger:HOLDoff

This command sets or queries the trigger holdoff, which is the time the instrument waits before arming the trigger system to accept triggers. Holdoff can help achieve stable triggering. Sending this command is equivalent to entering a value in the Holdoff control in the Trigger Setup dialog box.

Two primary factors determine what the minimum acceptable holdoff value may be at any given time.

- Hardware restrictions. There is a minimum time required from the acceptance of one trigger event until the next due to both trigger re-arm time and maximum sample rate requirements. These requirements result in an absolute minimum holdoff setting of 5 μ s (given appropriate instrument settings).
- Time of last sample. The instrument must use a holdoff setting that is at least greater than the time from the trigger event to the farthest sample in any waveform acquisition. For example, if you have the time/div set to 1 μ s/div with the horizontal timebase position set to minimum (about 18 ns), the operational (that is, actual) holdoff must be greater than: $19 \text{ ns} + 1 \mu\text{s}/\text{div} * 10 \text{ div} = 10.018 \mu\text{s}$ (the hardware restrictions cause the instrument to increase this value).

The following are many of the parameters, which affect the determination by the instrument of the minimum actual holdoff:

- Horizontal scale (that is, time/div)
- Horizontal position
- Horizontal timebase mode

- Horizontal FrameScan settings (when FrameScan is enabled)
- User (Channel) deskew

The query form of this command returns the actual holdoff value in use by the instrument.

Group

Trigger

Related Commands

HORizontal:MAin:Scale, HORizontal:Main:POSition,
TRIGger:INTRate, CH<x>:DESKew

Syntax 1

TRIGger:HOLDoff <NR3>

Syntax 2

TRIGger:HOLDoff?

Argument

NR3

This is the value of the holdoff time.

Example 1

TRIGger:HOLDoff 5.0E-6

This command sets the requested trigger holdoff to 5 μ s.

Example 2

TRIGger:HOLDoff?

This query might return :TRIGGER:HOLDOFF 6.000000000000E-006, indicating that the actual holdoff is set to 6 μ s.

TRIGger:INTRate

This command sets or queries the internal clock rate. The command sets the same parameter as the TDR:INTRate command. The internal clock in the instrument generates a continuous signal with selectable repetition rates of 200 kHz (default), 100 kHz, 50 kHz, and 25 kHz. Sending this command is equivalent to selecting a value for Internal Clock in the Trigger or TDR Setup dialog box. Use the TRIGger:SOURce command to select the internal clock. This internal clock rate can be used to synchronize the generation of TDR step pulses with the subsequent acquisition.

Group

Trigger

Related Commands

TDR:INTRate

Syntax 1

TRIGger:INTRate <NR3>

Syntax 2

TRIGger:INTRate?

Arguments

NR3

This argument sets the internal clock rate to one of the following: 25 kHz, 50 kHz, 100 kHz, or 200 kHz. You can input any NR3 value; the instrument will set the internal clock rate to the closest available setting.

Example 1

```
TRIGger:INTRate 100E3
```

This command sets the internal clock rate to 100 kHz.

Example 2

```
TRIGger:INTRate?
```

This query might return :TRIGGER:INTRATE
200.00000000000E+003, indicating that the internal clock rate is set to the default, 200 kHz.

TRIGger:LEVel

This command queries or sets the trigger level, which is applied only when the trigger source is set to External Direct (see the TRIGger:SOUrce command). The trigger level is the voltage threshold through which the trigger source signal must pass to generate a trigger event. This command is equivalent to setting a value for the level in the Level section of the Trigger Setup dialog box or adjusting the Trigger LEVEL control on the front panel.

Group

Trigger

Related Commands

TRIGger:SOUrce, TRIGger:SETLevel

Syntax 1

```
TRIGger:LEVel <NR3>
```

Syntax 2

```
TRIGger:LEVel?
```

Argument

NR3

This is the value of the trigger level in volts.

Example 1

```
TRIGger:LEVel 1.0E-1
```

This command sets the trigger level to 100 mV.

Example 2

```
TRIGger:LEVel?
```

This query might return `:TRIGGER:LEVEL 0.2410000000`, indicating that the trigger level is set to 241 mV.

TRIGger:METAReject

This command sets or queries the metastability rejection filter. Metastability is a phenomenon that occurs when both the trigger input signal and the holdoff generated re-enable signal arrive at the trigger recognizer at the same time (or within close proximity). Statistically, the occurrence of this phenomenon is extremely low. However, a trigger event generated under these conditions may result in incorrect acquisition of the sample. The metastability reject control enables or disables the detection of these metastable conditions. When you enable this control and a metastable condition is detected, the instrument replaces the potentially bad sample with a Null sample value. This command is equivalent to checking or clearing the Metastability Reject control in the Enhanced Triggering section of the Trigger Setup dialog box.

Group

Trigger

Syntax 1

```
TRIGger:METAReject {ON|OFF|NR1}
```

Syntax 2

```
TRIGger:METAReject?
```

Arguments

- ON
This turns on the metastability rejection filter.
- OFF
This turns off the metastability rejection filter.
- NR1
A 0 disables the metastability rejection filter; any other value enables the metastability rejection filter.

Example 1

```
TRIGger:METAReject 1
```

This command enables the metastability rejection filter.

Example 2

```
TRIGger:METAReject?
```

This query might return `:TRIGGER:METAREJECT 0`, indicating that the metastability rejection filter is disabled.

NOTE: A query always returns a 0 or 1.

TRIGger:MODE

This command sets or queries the trigger mode. This is equivalent to selecting Auto or Normal in the Mode section of the Trigger Setup dialog box. Auto or Normal mode applies only if the trigger source is set to External Direct or External Prescaler (see the TRIGger:SOUrce command).

In Normal mode, the instrument acquires data only if a valid trigger event occurs. Otherwise, the instrument stops acquiring data, freezing the display and halting trace calculation and measurement.

In Auto (Autotrigger) mode, if a trigger does not occur within 50 ms during any portion of an acquisition cycle, the instrument switches to the internal clock and provides enough triggers to finish the current acquisition cycle. As long as the instrument is in the running state, the next acquisition begins and the process is repeated (that is, another 50 ms must elapse before the instrument autotrigger again).

Group

Trigger

Related Commands

TRIGger:SOUrce

Syntax 1

```
TRIGger:MODE {NORMal|AUTO}
```

Syntax 2

```
TRIGger:MODE?
```

Arguments

- NORMal
This sets the trigger mode to Normal (see the command description above).
- AUTO
This sets the trigger mode to Auto (see the command description above).

Example 1

```
TRIGger:MODE NORMal
```

This sets the trigger mode to Normal.

Example 2

```
TRIGger:MODE?
```

This query might return `:TRIGGER:MODE AUTO`, indicating that the triggering mode is set to autotrigger.

TRIGger:SETLevel

This command (no query form) sets the trigger level automatically to 50% of the minimum/maximum value of the trigger input signal. This trigger level is effective only when the trigger source is set to External

Direct (see the TRIGger:SOUrce command). The trigger level is the voltage threshold through which the trigger source signal must pass to generate a trigger event. This command is equivalent to clicking Set to 50% in the Level section of the Trigger Setup dialog box or pressing the Trigger SET TO 50% button on the front panel.

Group

Trigger

Related Commands

TRIGger:SOUrce, TRIGger:LEVel

Syntax

TRIGger:SETLevel

Example

TRIGger:SETLevel

This command sets the trigger level to 50% of the applied signal.

TRIGger:SLOpe

This command sets or queries the trigger slope. The slope is applied only when trigger source is set to External Direct. See the TRIGger:SOUrce command. (For External Prescaler, Internal Clock, and Clock Recovery trigger sources, the slope is set internally to rising.) Sending this command is equivalent to selecting the rising or falling icon in the Slope section of the Trigger Setup dialog box.

Group

Trigger

Related Commands

TRIGger:SOUrce

Syntax 1

TRIGger:SLOpe {RISe|FALL}

Syntax 2

TRIGger:SLOpe?

Arguments

- RISe
This argument causes the instrument to trigger on the rising slope of the trigger source signal.
- FALL
This argument causes the instrument to trigger on the falling slope of the trigger source signal.

Example 1

TRIGger:SLOpe FALL

This command causes the instrument to trigger on the falling slope of the trigger source signal when the trigger source is set to External Direct.

Example 2

TRIGger: SLOpe?

This query might return :TRIGGER:SLOPE RISE, indicating that the instrument is set to trigger on the rising slope of the trigger source signal.

TRIGger:SOURce

This command sets or queries the trigger source, which provides the signal that triggers acquisition. This is equivalent to selecting one of the radio buttons in the Trigger Source section of the Trigger Setup dialog box.

There are four trigger sources from which you can choose: two derived from external inputs and two derived internally.

- **External Direct.** Select this trigger source to trigger on an external signal that you couple to the External Direct trigger input connectors on the instrument front panel. The input coupling mode is DC and triggering is usable with signals up to at least 3.0 GHz.
- **External Prescaler.** Select this trigger source to trigger on an external signal that you couple to the External Prescaler trigger input connector on the instrument front panel. The input coupling mode is DC. Triggering is usable with signals up to at least 12.5 GHz. The external signal you input is divided down (prescaled) before being applied to the trigger system. Use this type of trigger source for higher frequency signals that cannot be triggered on with External Direct.
- **Internal Clock.** Select this trigger source to trigger on an internal clock signal. Use the TRIGger:INTRate command to select a clock rate of 200 kHz (default), 100 kHz, 50 kHz, or 25 kHz. Use this type of trigger source with TDR to synchronize the generation of TDR step pulses with the subsequent acquisition. The Internal Clock Out connector supplies a sample of the internal clock at the instrument front panel.
- **Clock Recovery.** Select this trigger source to trigger on an external clock recovery trigger coupled to the clock recovery trigger input. This trigger source requires an optical sampling head that supports clock recovery. The sampling head picks the clock off internally and outputs it to the instrument for triggering. Use the TRIGger:CLKRec:SOURce command to select either Channel 1 or Channel 2 as the clock recovery channel source if more than one optical sampling module with clock recovery capability is installed in the instrument. Use the TRIGger:CLKRec:SOURce? query to determine which channel is currently selected as the clock recovery channel source.

Group

Trigger

Related Commands

TRIGger:INTRate, TRIGger:CLKRec:SOURce

Syntax 1

```
TRIGger:SOURce {EXTDirect|EXTPrescaler|INTClk  
|CLKREcovery}
```

Syntax 2

```
TRIGger:SOURce?
```

Argument

- `EXTDirect`
Sets the trigger source to External Direct (see the command description above).
- `EXTPrescaler`
Sets the trigger source to External Prescaler (see the command description above).
- `INTClk`
Sets the trigger source to Internal Clock (see the command description above).
- `CLKREcovery`
Sets the trigger source to Clock Recovery (see the command description above).

Example 1

```
TRIGger:SOURce EXTDirect
```

This command sets the trigger source to External Direct.

Example 2

```
TRIGger:SOURce?
```

This query might return `:TRIGGER:SOURCE INTCLK`, indicating that the trigger source is currently set to the internal clock.

TRIGger:STATE?

This query returns the status of the trigger system. The possible returns are `TRIGGERED`, `NOTTRIGGERED`, `STOPPED`, and `AUTOING`.

Group

Trigger

Syntax

```
TRIGger:STATE?
```

Example

```
TRIGger:STATE?
```

This query might return `:TRIGGER:STATE TRIGGERED`, indicating that the instrument is triggered.

TRIGger?

This query only command returns all the trigger parameters for the instrument.

Group

Trigger

Syntax

TRIGger?

Example

TRIGger?

This query might return : TRIGGER:HIFREQ 0;METAREJECT 0;HOLDOFF 6.000000000000E-006;INTRATE 200;LEVEL 0.190000000000;MODE NORMAL;SLOPE RISE;SOURCE EXTDIRECT;STATE TRIGGERED;CLKREC:SOURCE CH1::TRIGGER:CH1:CLKREC:LIST.

UNLock

This command unlocks the front panel and touchscreen. This command is equivalent to LOCK NONE. There is no query form for this command.

Note: If the instrument is in the Remote With Lockout State (RWLS), the UNLOCK command has no effect. For more information, see ANSI-IEEE Std. 488.1-1987 Standard Digital Interface for Programmable Instrumentation, section 2.8.3 on RL State Descriptions.

Group

Miscellaneous

Related Commands

LOCK

Syntax

UNLock ALL

Argument

ALL

This unlocks all front-panel buttons, knobs and the touchscreen.

Example

UNLock ALL

VERBose

Description

Sets and queries the verbose state that controls the length of keywords on query responses. Keywords can be both headers and arguments. This command does not affect IEEE Std 488.2-1987 Common Commands (those starting with an asterisk).

Group

Miscellaneous

Related Commands

HEADer, *LRN, SET?

Syntax 1

VERBose {OFF|ON|<NR1>}

Syntax 2

VERBose?

Arguments

- ON
Sets the verbose state true, which returns full-length keywords for applicable setting queries.
- OFF
Sets the verbose state false, which returns minimum-length keywords for applicable setting queries.
- NR1
0 sets the verbose state false, which returns minimum-length keywords for applicable setting queries; any other integer sets the verbose state true, which returns full-length keywords for applicable setting queries. A query always returns a 0 or 1.

Example 1

VERBose ON

Sets the verbose state true, which returns full-length keywords for queries.

Example 2

VERBose?

This query might return :VERBOSE 1, indicating that the verbose state is true.

NOTE: A query always returns a 0 or 1.

WAVFrm?

This is a query only command that returns CURVe? and WFMOupre? data (data and outgoing waveform preamble) for the waveform as specified by the DATA:SOURce command. This command is equivalent to sending the CURVe? and WFMOupre? commands.

Group

Waveform Transfer

Related Commands

CURVe?, DATA:SOURce, DATA:TIMEbase, WFMOupre?

Syntax

WAVFrm?

Example

WAVFrm?

This query might return the following (partial):

```

:WAVFRM -447610880,-467206144,-501547008,
-499187712,-513605632,-510001152,-511508480,
-519241728,-504365056,-504365056,-507576320,
-509214720,-509476864,-509476864,-509476864,
-505348096,-508559360,-511639552,-509739008,
-510984192,-513015808,-509214720,-510001152,
-508362752,-512688128,-512950272,-509083648,
-510328832,-511705088,-510197760,-508166144,
-506265600,-514588672,...:WFMOUTPRE:ENCDG ASCII;
BN_FMT RI;BYT_OR LSB;BYT_NR 4;BIT_NR 32;
NR_PT 500;PT_FMT Y;XINCR 500.000000000000E-012;
XZERO 18.0000000000008E-009;XUNIT "";
YMULT 0.100000000000000;XMULT 500.000000000000E-012;
XOFF 20.5000000000008E-009;YZERO 0.000000000000;
YSCALE 232.83064365443E-012;YOFF 0;YUNIT "";
WFID "Pulse Test, 100.0mV/div, 500.0ps/div,
500 points, Sample mode";WFMLABEL "Pulse Test"

```

WFMDB:DISPlay:EMPHasis

This command sets or queries the display emphasis for the WfmDB (waveform database). The value you specify sets the range of counts that you want to emphasize. The lowest value, 0, emphasizes bins with low counts; the highest value, 100, emphasizes bins with high counts. You can set the emphasis from 0% to 100%. This command is the equivalent to using the slide bar to set the Emphasize Counts percentage in the Display Options section of the WfmDB Setup dialog box.

Group

Waveform Database

Related Commands

WFMDB:DISPlay:GRADing, WFMDB:DISPlay:INVert

Syntax 1

```
WFMDB:DISPlay:EMPHasis <NR3>
```

Syntax 2

```
WFMDB:DISPlay:EMPHasis?
```

Argument

NR3

This is the percentage to which Emphasize Counts is set. The range is from 0 through 100.

Example 1

```
WFMDB:DISPlay:EMPHasis 0
```

This command sets the instrument to emphasize in the display bins with low counts.

Example 2

```
WFMDB:DISPlay:EMPHasis?
```

This query might return `:WFMDB:DISPLAY:EMPHASIS 50`, indicating that the Emphasize Counts is set to 50%.

WFMDB:DISPlay:GRADing

This command sets or queries which grading type (color or intensity) the instrument uses to draw the WfmDB. This is equivalent to selecting Color or Intensity for Grading in the Display Options section of the WfmDB Setup dialog box.

Group

Waveform Database

Related Commands

WFMDB:DISPlay:EMPHAsis, WFMDB:DISPlay:INVert

Syntax 1

```
WFMDB:DISPlay:GRADing {COLor|INTensity}
```

Syntax 2

```
WFMDB:DISPlay:GRADing?
```

Argument

- `COLor`
This argument maps the WfmDB display to colors. This is the default setting.
- `INTensity`
This argument maps the WfmDB display to intensity.

Example 1

```
WFMDB:DISPlay:GRADing COLor
```

This command sets the grading type for the WfmDB to color.

Example 2

```
WFMDB:DISPlay:GRADing?
```

This query might return `:WFMDB:DISPLAY:GRADING INTENSITY`, indicating that the grading type for the WfmDB display is set to intensity.

WFMDB:DISPlay:INVert

This command sets or queries whether the Color or Intensity grading is displayed inverted. When Invert is enabled, the mapping function that applies colors and intensity to the WfmDB significantly emphasizes the least occurring pixels. This is the equivalent to selecting or deselecting Invert Color/Intensity in the Display Options section of the WfmDB Setup dialog box.

Group

Waveform Database

Related Commands

WFMDB:DISPlay:EMPHasis, WFMDB:DISPlay:GRADing

Syntax 1

```
WFMDB:DISPlay:INVert {ON|OFF|NR1}
```

Syntax 2

```
WFMDB:DISPlay:INVert?
```

Argument

- ON
This argument enables the invert function.
- OFF
This argument disables the invert function.
- NR1
A 0 disables on the invert function; any other integer enables the invert function.

Example 1

```
WFMDB:DISPlay:INVert ON
```

This command enables the invert function.

Example 2

```
WFMDB:DISPlay:INVert?
```

This query might return :WFMDB:DISPlay:INVERT 0, indicating that the invert function is disabled.

Note: This query always returns 0 or 1.

WFMDB:DISPlay?

This query only command returns all the WfmDB display parameters.

Group

Waveform Database

Related Commands

WFMDB?

Syntax 1

```
WFMDB:DISPlay?
```

Example

```
WFMDB:DISPlay?
```

This query might return :WFMDB:DISPlay:EMPHASIS
50;GRADING COLOR;INVERT 0.

WFMDB:WFMDB<x>:CLEAR

This command (no query form) resets to zero (clears) the counts in the specified WfmDB. The WfmDB is specified by x, which can be 1 or 2.

(Sending the ACQUIRE:DATA:CLEAR command has the same effect on the WfmDB.)

Group

Waveform Database

Related Commands

ACQUIRE:DATA:CLEAR

Syntax

```
WFMDB:WFMDB<x>:CLEAR
```

Example

```
WFMDB:WFMDB1:CLEAR
```

This command clears the counts in WfmDB 1 (Waveform Database1).

WFMDB:WFMDB<x>:DISPlay

This command displays the specified WfmDB waveform. The query form of this command returns whether or not the specified WfmDB waveform is displayed. The WfmDB is specified by *x*, which can be 1 or 2. This command is the equivalent to checking the Display Database control in the Database1 or Database2 sections of the WfmDB Setup dialog box.

Group

Waveform Database

Syntax 1

```
WFMDB:WFMDB<x>:DISPlay {ON|OFF|NR1}
```

Syntax 2

```
WFMDB:WFMDB<x>:DISPlay?
```

Argument

- ON
This enables the display of the specified WfmDB waveform.
- OFF
This disables the display of the specified WfmDB waveform. This is the default setting.
- NR1
A 0 disables the display of the specified WfmDB waveform; any other integer value enables the display of the specified WfmDB waveform.

Example 1

```
WFMDB:WFMDB1:DISPlay ON
```

This command enables the waveform display for Database 1.

Example 2

```
WFMDB:WFMDB2:DISPlay?
```

This query might return `:WFMDB:WFMDB2:DISPLAY 0`, indicating that the Database 2 waveform display is disabled.

Note: This query always returns a 0 or 1.

WFMDB:WFMDB<x>:ENABLE

This command sets or queries whether the specified waveform database (WfmDB) is enabled. The WfmDB is specified by `x`, which can be 1 or 2. This command is the equivalent to selecting or deselecting the On check in the Database1 or Database2 sections of the Wfm Database Setup dialog box. Use the `WFMDB:WFMDB<x>:DISPlay` command to control whether or not the waveform database is displayed.

Group

Waveform Database

Related Commands

`WFMDB:WFMDB<x>:DISPlay`

Syntax 1

```
WFMDB:WFMDB<x>:ENABLE {ON|OFF|NR1}
```

Syntax 2

```
WFMDB:WFMDB<x>:ENABLE?
```

Argument

- ON
This enables the display of the specified WfmDB waveform.
- OFF
This disables the display of the specified WfmDB waveform. This is the default setting.
- NR1
A 0 disables the display of the specified WfmDB waveform; any other integer value enables the display of the specified WfmDB waveform.

Example 1

```
WFMDB:WFMDB1:ENABLE ON
```

This command enables the waveform display for Database 1.

Example 2

```
WFMDB:WFMDB2:ENABLE?
```

This query might return `:WFMDB:WFMDB2:ENABLE 0`, indicating that the Database 2 waveform display is disabled.

Note: This query always returns a 0 or 1.

WFMDB:WFMDB<x>:SOURCE

This command sets or queries the source of the WfmDB specified by `x`, which can be 1 or 2. This command can optionally set the timebase. This

is the equivalent to selecting a source (and timebase) in the Source control for the Database1 or the Database2 sections of the WfmDB Setup dialog box. If you do not set the timebase, the default is Main.

Group

Waveform Database

Syntax 1

```
WFMDB:WFMDB<x>:SOURCE {CH<x>|MATH<x>}  
[ , {MAIN|MAG1|MAG2} ]
```

Syntax 2

```
WFMDB:WFMDB<x>:SOURCE?
```

Argument

- CH<x>
This argument selects a channel waveform as the source for the specified WfmDB. The range for x is 1 through 8.
- MATH<x>
This argument selects a math waveform as the source for the specified WfmDB. The range for x is 1 through 8.
- MAIN
This optional argument selects Main as the timebase for the specified WfmDB display. This is the default timebase.
- MAG1
This optional argument selects MAG1 as the timebase for the specified WfmDB display.
- MAG2
This optional argument selects MAG2 as the timebase for the specified WfmDB display.

Example 1

```
WFMDB:WFMDB1:SOURCE CH4
```

This command sets Channel 4 as the source for WfmDb1.

Example 2

```
WFMDB:WFMDB<x>:SOURCE?
```

This query might return :WFMDB:WFMDB2:SOURCE MATH2, MAIN, indicating that the Math 1 waveform is set as the source for WfmDB2 and is displayed with the Main timebase.

WFMDB:WFMDB<x>?

This query only command returns the waveform database parameters for the WfmDB specified by x, which can be 1 or 2.

Group

Waveform Database

Syntax

WFMDB:WFMDB<x>?

Example

WFMDB:WFMDB2?

This query might return :WFMDB:WFMDB2:SOURCE
REF1,MAIN;DISPLAY 1;ENABLE 1.

WFMDB?

This query only command returns all the waveform database parameters.

Group

Waveform Database

Related Commands

WFMDB:DISPlay?

Syntax 1

WFMDB?

Example

WFMDB?

This query might return :WFMDB:DISPLAY:EMPHASIS
32;GRADING COLOR;INVERT 1;:WFMDB:WFMDB1:SOURCE
CH1,MAIN;DISPLAY 1;ENABLE 1;:WFMDB:WFMDB2:SOURCE
CH1,MAIN;DISPLAY 0;ENABLE 0.

WFMInpre:BIT_Nr?

This query only command returns the number of bits (width) per waveform point for the waveform to be transferred to the instrument.

Note: This instrument supports only the 32-bit format.

Group

Waveform Transfer

Related Commands

WFMInpre:BYT_Nr?

Syntax

WFMInpre:BIT_Nr?

Example

WFMInpre:BIT_Nr?

This query might return :WFMINPRE:BIT_NR 32, indicating that there are 32 bits per waveform point.

WFMInpre:BN_Fmt

This command sets or queries the format of the binary or ascii data encoding of the waveform to be transferred to the instrument.

Group

Waveform Transfer

Related Commands

DATA:ENCdg, WFMInpre:BYT_Or, WFMInpre:ENCdg

Syntax 1

WFMInpre:BN_Fmt {RI|FP}

Syntax 2

WFMInpre:BN_Fmt?

Arguments

- RI
This argument specifies signed integer data-point representation.
- FP
This argument specifies floating-point data-point representation.

Example 1

WFMInpre:BN_FMT RI

This command specifies that the binary or ascii waveform data values are signed integer data points.

Example 2

WFMInpre:BN_FMT?

This query might return :WFMPRE:BN_FMT FP, indicating that the waveform data format for transferring a waveform is floating point.

WFMInpre:BYT_Nr?

This query only command returns the byte width of the waveform to be transferred to the instrument.

Note: This instrument supports only a 4-byte width format.

Group

Waveform Transfer

Related Commands

WFMInpre:BIT_Nr?

Syntax

WFMInpre:BYT_Nr?

Example

WFMInpre:BYT_Nr?

This query might return :WFMINPRE:BYT_NR 4, indicating that the byte width for waveform data is four bits.

WFMInpre:BYT_Or

Selects which byte of binary waveform data is transmitted first during a waveform data transfer to the instrument.

Group

Waveform Transfer

Related Commands

DATA:ENCdg, WFMInpre:BN_Fmt, WFMInpre:ENCdg

Syntax 1

WFMInpre:BYT_Or {LSB|MSB}

Syntax 2

WFMInpre:BYT_Or?

Arguments

- LSB
This argument selects the least-significant byte to be transmitted first.
- MSB
This argument selects the most-significant byte to be transmitted first.

Example 1

WFMInpre:BYT_OR MSB

This command specifies that the most-significant byte in the waveform data will be transferred first.

Example 2

WFMInpre:BYT_OR?

This query might return :WFMINPRE:BYT_O MSB, indicating that the most-significant byte in the waveform data will be transmitted first.

WFMInpre:ENCdg

This command sets or queries the type of encoding used for waveform data transferred with the CURVe command.

Group

Waveform Transfer

Related Commands

DATA:ENCdg, WFMInpre:BYT_Or , WFMInpre:BN_Fmt

Syntax 1:

WFMInpre:ENCdg {ASCIi|BINary}

Syntax 2

WFMInpre:ENCdg?

Arguments

- `ASCIi`
This argument sets the encoding for waveform data transfer to ASCII format.
- `BINary`
This argument sets the encoding for the waveform data transfer to binary format.

Example 1

```
WFMInpre:ENCdg ASCII
```

This command specifies that the input waveform data is in ASCII format.

Example 2

```
WFMInpre:ENCdg?
```

This query might return `:WFMINPRE:ENCDG BIN`, indicating that the waveform data is in binary format.

WFMInpre:NR_Pt

This command sets or queries the record length of the input waveform. The query returns the allocated record length of the input waveform. This is the number of points in the curve plus any additional NULL values to fill the record. Any additional input points will be discarded. Valid record lengths are 20, 50, 100, 250, 500, 1000, 2000, and 4000. When using this command to set the record length of the input waveform and the input value is different from one of the valid record lengths, the value will be coerced to the next higher valid record length. An event will then be generated.

Group

Waveform Transfer

Related Commands

`CURVe`, `DATa:STOP`, `DATa:START`, `DATa:DESTINATION`

Syntax 1

```
WFMInpre:NR_Pt <NR1>
```

Syntax 2

```
WFMInpre:NR_Pt?
```

Argument

`NR1`

This argument is a valid record length. It can be 20, 50, 100, 250, 500, 1000, 2000, and 4000.

Example 1

```
WFMInpre:NR_Pt 2000
```

This command sets the record length to 2000.

Example 2

WFMInpre:NR_Pt?

This query might return :WFMINPRE:NR_PT 4000, indicating that the record length for the input waveform is set to 4000.

WFMInpre:PT_Fmt

This command sets or queries the data point format of the incoming waveform.

Group

ACQUIRE:MODE

Related Commands

DATA:DESTINATION

Syntax

WFMInpre:PT_Fmt {Y|ENV}

Arguments

- Y

This argument specifies a standard waveform where one ASCII or binary point is transmitted for each point in the waveform record. Only y values are explicitly transmitted. Absolute coordinates are given by:

$$X(n) = 0 + (XINcr * n) + XZErO$$

$$Y(n) = (YSCALE * y(n)) + YZErO$$

where $n = 0, 1, \dots$

- ENV

This argument specifies that the waveform is transmitted as min and max pairs. Absolute coordinates are given by:

$$X(n) = XINcr (INT(n/2) + XZErO$$

$$Y(n(\max)) = YSCALE * y(n(\max)) + YZErO$$

$$Y(n(\min)) = YSCALE * y(n(\min)) + YZErO$$

Example 1

WFMInpre:PT_Fmt ENV

This command sets the waveform data point format to enveloped.

Example 1

WFMInpre:PT_Fmt?

This query might return :WFMINPRE:PT_FMT Y, which indicates that the data is transmitted as a standard waveform.

WFMInpre:WFMLabel

This command sets or queries the label for the incoming waveform. Sending this command is equivalent to selecting Waveform Properties from the Utilities menu and entering a label in the Waveform Label field.

Group

Waveform Transfer

Syntax 1

```
WFMInpre:WFMLabel <Qstring>
```

Syntax 2

```
WFMInpre:WFMLabel?
```

Arguments

Qstring

This argument sets the label for the incoming waveform.

Example 1

```
WFMInpre:WFMLabel "Pulse Test"
```

This command sets the label for the incoming waveform to Pulse Test.

Example 2

```
WFMInpre:WFMLabel?
```

This query might return :WFMINPRE:WFMLABEL "Test 4", indicating that the label for the incoming waveform is set to Test 4.

WFMInpre:XINcr

This command sets or queries the interval between samples of the incoming waveform

Group

Waveform Transfer

Related Commands

```
HORizontal:MAIn:RESolution?
```

Syntax 1

```
WFMInpre:XINcr <NR3>
```

Syntax 2

```
WFMInpre:XINcr?
```

Argument

NR3

This argument is the sampling interval in seconds per point.

Example 1

```
WFMInpre:XINcr 1.0E-9
```

This command sets the horizontal sampling interval to 1 ns.

Example 2

```
WFMInpre:XINcr?
```

This query might return :WFMINPRE:XINCR 5.000000000000E-009, indicating that the interval between samples is 5 ns.

WFMinpre:XMULT

This command sets or queries the horizontal scale factor (horizontal units per division) of the incoming waveform.

Group

Waveform Transfer

Related Commands

HORizontal:MAIn:SCAlE

Syntax 1

```
WFMinpre:XMULT <NR3>
```

Syntax

```
WFMinpre:XMULT?
```

Argument

NR3

This argument is the horizontal scale factor of the incoming waveform.

Example 1

```
WFMinpre:XMULT 1.0E-5
```

This command sets the horizontal scale factor to 10 μ s per division.

Example 2

```
WFMinpre:XMULT?
```

This query might return `:WFMINPRE:XMULT 1.00000000000E-009`, indicating that the horizontal scale factor of the waveform to be transferred is set to 1 ns per division.

WFMinpre:XOFF

This command sets or queries the horizontal position in horizontal units of the incoming waveform.

Group

Waveform Transfer

Related Commands

HORizontal:MAIn:POSition

Syntax 1

```
WFMinpre:XOFF <NR3>
```

Syntax 2

```
WFMinpre:XOFF?
```

Argument

NR3

This argument is the horizontal position in horizontal units.

Example 1

```
WFMinpre:XOFF 6.5E-8
```

This command sets the horizontal position for the incoming waveform to 65 ns.

Example 2

```
WFMInpre:XOFF?
```

This query might return `:WFMINPRE:XOFF 2.0E-8`, indicating that the horizontal position for the waveform to be transferred is set to 20 ns.

WFMInpre:XUNit

This command sets or queries the horizontal (x-axis) units of the incoming waveform.

Group

Waveform Transfer

Related Commands

HORizontal:UNIts

Syntax 1

```
WFMInpre:XUNit <QString>
```

Syntax 2

```
WFMInpre:XUNit?
```

Argument

QString

This argument is a quoted string.

Example 1

```
WFMInpre:XUNit "s"
```

This command sets the horizontal units to seconds.

Example 2

```
WFMInpre:XUNit?
```

This query might return `:WFMINPRE:XUNIT "s"`, indicating that the horizontal units of the incoming waveform are seconds.

WFMInpre:XZEro

This command sets or queries the horizontal (x-axis) origin offset (time of first point in this instrument) of the incoming waveform. The time of first point is the time interval between the trigger point and the first point in the record (waveform).

Group

Waveform Transfer

Related Commands

HORizontal:MAIn:TOFPoint?

Syntax 1

```
WFMInpre:XZEro <NR3>
```

Syntax 2

WFMInpre:XZErO?

Argument

NR3

This argument is the time interval between the trigger point and the first point in the waveform record.

Example 1

WFMInpre:XZErO 20E-9

This command sets the horizontal origin offset (time of first point) to 20 ns for the incoming waveform. This is the time interval between the trigger point and the first point in the waveform record.

Example 2

WFMInpre:XZErO?

This query might return :WFMINPRE:XZERO 5.000000000000E-8, indicating that the time interval between the trigger point and the first point in the incoming waveform record is 50 ns.

WFMInpre:YMUIt

This command sets or queries the vertical scale in vertical units per division of the incoming waveform returned by the previous CURve? command.

Group

Waveform Transfer

Related Commands

CH<x>:SCAlE

Syntax 1

WFMInpre:YMUIt <NR3>

Syntax 2

WFMInpre:YMUIt?

Argument

NR3

This argument is the vertical scale factor in YUNits (usually volts) per division of the incoming waveform.

Example 1

WFMInpre:YMUIt 5.0E-3

This command sets the vertical scale factor of the incoming waveform to 5 mV per division.

Example 2

WFMInpre:YMUIt?

This query might return `:WFMINPRE:YMULT 0.100000000000`, indicating that the vertical scale of the incoming waveform is set to 100 mV per division.

WFMinpre:YOFF

This command sets or queries the vertical position of the incoming waveform in divisions.

Group

Waveform Transfer

Related Commands

CH<x>:POSITION

Syntax 1

WFMinpre:YOFF <NR3>

Syntax 2

WFMinpre:YOFF?

Argument

NR3

This argument is the vertical position in divisions of the incoming waveform.

Example 1

WFMinpre:YOFF 1.0E+0

This command sets the vertical position to 1 division.

Example 2

WFMinpre:YOFF?

This query might return `:WFMINPRE:YOFF -2`, indicating that the vertical position of the incoming waveform is -2 divisions.

WFMinpre:YSCALE

This command sets or queries the vertical unit scale factor of the incoming waveform. The value in vertical units is calculated by the following formula: $Vertical\ Units = (Raw\ Data) * YSCALE + YZERO$.

Group

Waveform Transfer

Syntax 1

WFMinpre:YSCALE <NR3>

Syntax 2

WFMinpre:YSCALE?

Argument

NR3

This argument is the value of the vertical scale factor. NOTE that the argument is always 1 when DATA:SOURCE is set to a math waveform.

Example 1

```
WFMInpre:YSCALE 9.20e-10
```

This command sets the vertical unit scale factor of the incoming waveform to 920E-12.

Example 2

```
WFMInpre:YSCALE?
```

This query might return `:WFMINPRE:YSCALE 9.20E10`, indicating that the vertical unit scale factor of the incoming waveform is 920 pV.

WFMInpre:YUNit

This command sets or queries the vertical (y-axis) units of the incoming waveform.

Group

Waveform Transfer

Related Commands

CH<x>:UNIts

Syntax 1

```
WFMInpre:YUNit <QString>
```

Syntax 2

```
WFMInpre:YUNit?
```

Argument

QString

This argument sets the vertical units of the incoming waveform.

Example 1

```
WFMInpre:YUNit "W"
```

This command sets the vertical units of the incoming waveform to watts.

Example 2

```
WFMInpre:YUNit?
```

This query might return `:WFMINPRE:YUNIT "V"`, indicating that the vertical units of the incoming waveform are volts.

WFMInpre:YZEro

This command sets or queries the vertical offset voltage of the incoming waveform.

Group

Waveform Transfer

Related Commands

CH<x>:OFFSet

Syntax 1

```
WFMInpre:YZEro <NR3>
```

Syntax 2

WFMInpre:YZero?

Argument

NR3

This is the vertical offset in volts of the incoming waveform.

Example 1

WFMInpre:YZero 5.0E-6

This command sets the vertical offset of the incoming waveform to 5 μ V

Example 2

WFMInpre:YZero?

This query might return :WFMINPRE:YZERO 1.00000000000E-006, indicating that the vertical offset of the incoming waveform is 1 μ V.

WFMInpre?

This is a query only that returns the waveform formatting data (preamble) for the incoming waveform.

Group

Waveform Transfer

Syntax

WFMINPre?

Example

WFMINPre?

This query might return the following:

```
:WFMINPRE:ENCDG ASCII;BN_FMT RI;BYT_OR LSB;BYT_NR
4;BIT_NR 32;NR_PT 500;PT_FMT Y;XINCR 1.00000000000E-
006;XZERO 16.00000000008E-009;XUNIT "nuts";YMULT
0.100000000000;XMULT 100.00000000000E-012;XOFF
65.00000000008E-009;YZERO 1.00000000000E-006;YSCALE
5.00000000000E-003;YOFF -2;YUNIT "";WFMLABEL ""
```

WFMOutpre:BIT_Nr?

This query only command returns the number of bits (width) per waveform point of the waveform to be transferred from the instrument.

Note: This instrument supports only a 32-bit format.

Group

Waveform Transfer

Related Commands

WFMOutpre:BYT_Nr?

Syntax 2

WFMOutpre:BIT_Nr?

Example

WFMOutpre:BIT_Nr?

This query might return :WFMPRE:BIT_NR 32, indicating that there are 32 bits per waveform point.

WFMOutpre:BN_FMT

This command sets or queries the format of the binary data encoding of the waveform to be transferred from the instrument. Sending this command will coerce DATA:ENCdg to a corresponding setting based on binary format and order.

Group

Waveform Transfer

Related Commands

DATA:ENCdg, WFMOutpre:BYT_Or, WFMOutpre:ENCdg

Syntax 1

WFMOutpre:BN_Fmt {RI|FP}

Syntax 2

WFMOutpre:BN_Fmt?

Arguments

- RI
This argument specifies signed integer data-point representation.
- FP
This argument specifies floating-point data-point representation.

Example 1

WFMOutpre:BN_FMT RI

This command specifies that the binary waveform data are signed integer data points.

Example 2

WFMOutpre:BN_FMT?

This query might return :WFMPRE:BN_FMT FP, indicating that the current waveform data format is floating point binary.

WFMOutpre:BYT_Nr?

This query only command returns the byte width for the waveform to be transferred from the instrument.

Note: This instrument supports only 4-byte data widths.

Group

Waveform Transfer

Related Commands

WFMOutpre:BIT_Nr?

Syntax

WFMOutpre:BYT_Nr?

Example

WFMOutpre:BYT_Nr?

This query might return :WFMOUTPRE:BYT_NR 4, indicating that the byte width for waveform data is 4.

WFMOutpre:BYT_Or

Selects which byte of binary waveform data is transmitted first during a waveform data transfer. If binary encoding is selected, this command will coerce DATA:ENCdg to corresponding settings based on the binary format and order.

Group

Waveform Transfer

Related Commands

DATA:ENCdg, WFMOutpre:BN_Fmt, WFMOutpre:ENCdg

Syntax 1

WFMOutpre:BYT_Or {LSB|MSB}

Syntax 2

WFMOutpre:BYT_Or?

Arguments

- LSB
This argument selects the least-significant byte to be transmitted first.
- MSB
This argument selects the most-significant byte to be transmitted first.

Example 1

WFMOutpre:BYT_OR MSB

This command specifies that the most-significant byte in the waveform data will be transferred first.

Example 2

WFMOutpre:BYT_OR?

This query might return :WFMOUTPRE:BYT_O MSB, indicating that the most-significant byte in the waveform data will be transmitted first.

WFMOutpre:ENCdg

This command sets or queries the type of encoding used for waveform data transferred with the CURVe? command. Using this command to change the type of encoding also changes the encoding set by the DATA:ENCdg command.

Group

Waveform Transfer

Related Commands

DATA:ENCdg, WFMOuTpre:BYT_Or, WFMOuTpre:BN_Fmt

Syntax 1:

```
WFMOuTpre:ENCdg {ASCIi|BINary}
```

Syntax 2

```
WFMOuTpre:ENCdg?
```

Arguments

- `ASCIi`
This argument sets the encoding for waveform data transfer to ASCII curve data. The output will be formatted to floating point or integer, based on how the data is stored in the instrument.
- `BINary`
This argument sets the encoding for the waveform data transfer to binary format. This will coerce DATA:ENCdg to a corresponding setting based on binary format and order.

Example 1

```
WFMOuTpre:ENCdg ASCIi
```

This command specifies that the waveform data is in ASCII format.

Example 2

```
WFMOuTpre:ENCdg?
```

This query might return `:WFMOUPTPRE:ENCDG BINARY`, indicating that the waveform data is in binary format.

WFMOuTpre:NR_Pt?

This is a query only command that returns the number of points that were returned by the previous CURVe? command. The number of points is the greater of the absolute value of (DATA:STOP – DATA:START) +1, or the record length of the source waveform specified by the DATA:SOURce command.

Group

Waveform Transfer

Related Commands

CURVe?, DATA:STOP, DATA:START, DATA:SOURce, DATA:TIMEbase

Syntax

```
WFMOuTpre:NR_Pt?
```

Example

```
WFMOuTpre:NR_Pt?
```

This query might return :WFMOU

```
PRE:NR_PT 500.
```

WFMO ``` utpre:PT_Fmt? ```

This is a query only command that returns the data point format of the waveform returned by the previous CUR

```
ve?
```

 command.

Group

Waveform Transfer

Related Commands

ACQ

```
uire:MODE?
```

Syntax

WFMO

```
utpre:PT_Fmt?
```

Returns

This query returns either Y, which specifies a standard waveform where one ASCII or binary point is transmitted for each point in the waveform record, or ENV, which specifies that the waveform is transmitted as min and max pairs.

Example

WFMO

```
utpre:PT_Fmt?
```

This query might return :WFMOU

```
PRE:PT_FMT Y
```

, which indicates that the data is transmitted as a standard waveform.

WFMO ``` utpre:WFId? ```

This is a query only command that returns a descriptive string of the waveform returned by the previous CUR

```
ve?
```

 command.

Group

Waveform Transfer

Syntax

WFMO

```
utpre:WFId?
```

Example

WFMO

```
utpre:WFId?
```

This query might return :WFMOU

```
PRE:WFID "C3, 100.0mV/div, 5.000ns, 500 points, Sample mode"
```

.

WFMO ``` utpre:WFMLLabel? ```

This is query only command that returns the label for the previous waveform transferred by the CUR

```
ve?
```

 command.

Group

Waveform Transfer

Syntax

WFMO

```
utpre:WFMLLabel?
```

Example

WFMOutpre:WFMLabel?

This query might return :WFMOutpre:WFMLabel "Pulse Test".

WFMOutpre:XINcr?

This is a query only command that returns the interval between samples of the waveform transferred by the CURve? command.

Group

Waveform Transfer

Related Commands

HORizontal:MAIn:RESolution?

Syntax

WFMOutpre:XINcr?

Example

WFMOutpre:XINcr?

This query might return :WFMOUTPRE:XINCR 5.0000000000E-009, indicating that the interval between samples of the previously transferred waveform was 5 ns.

WFMOutpre:XMUIt?

This is a query only command that returns the horizontal scale factor of the waveform returned by the previous CURve? command.

Group

Waveform Transfer

Related Commands

HORizontal:MAIn:SCAle?

Syntax

WFMOutpre:XMUIt?

Example

WFMOutpre:XMUIt?

This query might return :WFMOUTPRE:XMULT 5.0000000000E-006, indicating that the horizontal scale factor of the previously transferred waveform was set to 5 μ s per division.

WFMOutpre:XOFF?

This is a query only command that returns the horizontal position in horizontal units of the returned waveform.

Group

Waveform Transfer

Related Commands

HORizontal:MAIn:POSition?

Syntax

WFMOutpre:XOFF?

Example

WFMOutpre:XOFF?

This query might return :WFMOUTPRE:XOFF 20.50000000008E-009, indicating that the horizontal position for the previously transferred waveform was set to 20.5 ns.

WFMOutpre:XUNit?

This is a query only command that returns the horizontal units of the waveform returned by the previous CURve? command.

Group

Waveform Transfer

Related Commands

HORizontal:UNIts?

Syntax

WFMOutpre:XUNit?

Example

WFMOutpre:XUNit?

This query might return :WFMOUTPRE:XUNIT "s", indicating that the horizontal units of the previously acquired waveform were seconds.

WFMOutpre:XZEro?

This is a query only command that returns the time of first point (sample) of the waveform returned by the previous CURve? command.

Group

Waveform Transfer

Related Commands

HORizontal:MAIn:TOFPoint?

Syntax

WFMOutpre:XZEro?

Example

WFMOutpre:XZEro?

This query might return :WFMOUTPRE:XZERO 19.00000000008E-009, indicating that the time interval between the trigger point and the first point in the previous waveform record was 19 ns.

WFMOutpre:YMUIt?

This is a query only command that returns the vertical scale factor in vertical units per division of the waveform returned by the previous CURve? command.

Group

Waveform Transfer

Related Commands

CH<x>:SCAlE?

Syntax

WFMOutpre:YMUIt?

Example

WFMOutpre:YMUIt?

This query might return :WFMOUTPRE:YMULT 0.100000000000, indicating that the vertical scale of the previously transferred waveform was set to 100 mV per division.

WFMOutpre:YOFF?

This is a query only command that returns the vertical position of the waveform returned by the previous CURve? command.

Group

Waveform Transfer

Related Commands

CH<x>:POSition?

Syntax

WFMOutpre:YOFF?

Example

WFMOutpre:YOFF?

This query might return :WFMOUTPRE:YOFF 0, indicating that the vertical position of the previously transferred waveform was at the centerline.

WFMOutpre:YSCALE?

This query only command returns vertical unit scale factor of the incoming waveform by the previous CURve? command. The value in vertical units is calculated by the following formula: *Vertical Units = (Raw Data) x YSCALE + YZERO*.

Note. If the DATA:SOURCE is a math waveform, the WFMOUTPRE:YSCALE value is always 1. If the data source is a reference waveform, then the WFMOUTPRE:YSCALE value depends on the original source data.

Group

Waveform Transfer

Syntax

WFMOutpre:YSCALE?

Example

WFMOutpre:YSCALE?

This query might return :WFMOUTPRE:YSCALE

9.200000000000E10, indicating that the vertical unit scale factor of the incoming waveform is 920p

WFMOutpre:YUNit?

This is a query only command that returns the vertical units of the waveform returned by the previous CURve? command.

Group

Waveform Transfer

Related Commands

CH<x>:UNIts

Syntax

WFMOutpre:YUNit?

Example

WFMOutpre:YUNit?

This query might return :WFMOUTPRE:YUNIT "V", indicating that the vertical units of the previously transferred waveform were volts.

WFMOutpre:YZEro?

This is a query only command that returns the vertical offset of the waveform returned by the previous CURve? command.

Group

Waveform Transfer

Related Commands

CH<x>:OFFSet?

Syntax

WFMOutpre:YZEro?

Example

WFMOutpre:YZEro?

This query might return :WFMOUTPRE:YZERO 1.0000000000E-001, indicating that the vertical offset of the previously transferred waveform was 100 mV.

WFMOutpre?

This is a query only command that returns the preamble for the outgoing waveform. This data always corresponds to the previous CURVe? command (the returned parameters do not necessarily correspond to the current waveform settings made by the DATA:SOURce command). A CURVe? command must precede the WFMOutpre? query to get corresponding header/data information.

Group

Waveform Transfer

Related Commands

CURVe?, WAVFrm?

Syntax

WFMOutpre?

Example

WFMOutpre?

This query might return :WFMOUTPRE:ENCDG ASCII;BN_FMT RI;BYT_OR_LSB;BYT_NR 4;BIT_NR 32;NR_PT 500;PT_FMT Y;XINCR 500.000000000000E-012;XZERO 18.000000000008E-009;XUNIT "";YMULT 0.100000000000;XMULT 500.000000000000E-012;XOFF 20.500000000008E-009;YZERO 0.000000000000;YSCALE 232.83064365432E-012;YOFF 0;YUNIT "";WFID "Pulse Test, 100.0mV/div, 500.0ps/div, 500 points, Sample mode";WFMLABEL "Pulse Test"

Status and Events

The instrument provides a status and event reporting system for the GPIB interface. This system informs you of certain significant events that occur within the instrument.

The instrument status handling system consists of five 8-bit registers and two queues. The remaining Status subtopics describe these registers and components. They also explain how the event handling system operates.

Related Topics

- Registers
- Queues
- Event Handling Sequence
- Synchronizations Methods
- Messages

Registers

Overview

The registers in the event handling system divide into two functional groups:

- Status Registers contain information about the status of the instrument. These registers include the Standard Event Status Register (SESR) and the Status Byte Register (SBR).
- Enable Registers determine whether selected types of events are reported to the Status Registers and the Event Queue. They include the Device Event Status Enable Register (DESER), the Event Status Enable Register (ESER), and the Service Request Enable Register (SRER).

Status Registers

The Standard Event Status Register (SESR) and the Status Byte Register (SBR) record certain types of events that may occur while the instrument is in use. IEEE Std 488.2-1987 defines these registers.

Each bit in a Status Register records a particular type of event, such as an execution error or message available. When an event of a given type occurs, the instrument sets the bit that represents that type of event to a value of one. (You can disable bits so that they ignore events and remain at zero. See *Enable Registers* on page 339.) Reading the status registers tells you what types of events have occurred.

The Standard Event Status Register (SESR). The SESR records eight types of events that can occur within the instrument. Use the *ESR? query to read the SESR register. Reading the register clears the bits of the register so that the register can accumulate information about new events.

Standard Event Status Register (SESR)

7	6	5	4	3	2	1	0
PON	URQ	CME	EXE	DDE	QYE	RQC	OPC

SESR Bit Functions

Bit	Function	
7 (MSB)	PON	Power On. Shows that the instrument was powered on. On completion, the diagnostic tests also set this bit.
6	URQ	User Request. Shows that an Application menu button was pressed.
5	CME	Command Error. Shows that an error occurred while the instrument was parsing a command or query. Command error messages are listed in Table 3-4 below.
4	EXE	Execution Error. Shows that an error occurred while the instrument was executing a command or query. Execution error messages are listed in Table 3-5 below.
3	DDE	Device Error. Shows that a device error occurred. Device error messages are listed in Table 3-6 below.
2	QYE	Query Error. Shows that an attempt was made to read the Output Queue when no data was present or pending, the query was unterminated, the query was interrupted, or that data in the Output Queue was lost.
1	RQC	Request Control. This is not used.
0 (LSB)	OPC	Operation Complete. Shows that the operation is complete. This bit is set when all pending operations complete following an *OPC command.

The Status Byte Register (SBR). This register records whether output is available in the Output Queue, whether the instrument requests service, and whether the SESR has recorded any events.

Use a Serial Poll or the *STB? query to read the contents of the SBR. The bits in the SBR are set and cleared depending on the contents of the SESR, the Event Status Enable Register (ESER), and the Output Queue. When you use a Serial Poll to obtain the SBR, bit 6 is the RQS bit. When you use the *STB? query to obtain the SBR, bit 6 is the MSS bit. Reading the SBR does not clear the bits.

Status Byte Register (SBR)

7	6	5	4	3	2	1	0
----	RQS	ESB	MAV	----	----	----	----
	MSS						

SBR Bit Functions

Bit	Function	
7 (MSB)	-----	Not used.
6	RQS	Request Service. Obtained from a serial poll. Shows that the instrument requests service from the GPIB controller.
6	MSS	Master Status Summary. Obtained from *STB? query. Summarizes the ESB and MAV bits in the SBR.
5	ESB	Event Status Bit. Shows that status is enabled and present in the SESR.
4	MAV	Message Available. Shows that output is available in the Output Queue.
3	-----	Not used.
2	-----	Not used.
1 – 0	-----	Not used.

Enable Registers

DESER, ESER, and SRER allow you to select which events are reported to the Status Registers and the Event Queue. Each Enable Register acts as a filter to a Status Register (the DESER also acts as a filter to the Event Queue) and can prevent information from being recorded in the register or queue.

Each bit in an Enable Register corresponds to a bit in the Status Register that it controls. For an event to be reported to its bit in the Status Register, the corresponding bit in the Enable Register must be set to one. If the bit in the Enable Register is set to zero, the event is not recorded.

Various commands set the bits in the Enable Registers. The Enable Registers and the commands used to set them are described below.

The Device Event Status Enable Register (DESER). This register controls which types of events are reported to the SESR and the Event Queue. The bits in the DESER correspond to those in the SESR.

Use the DESE command to enable and disable the bits in the DESER. Use the DESE? query to read the DESER.

Device Event Status Enable Register (DESER)

7	6	5	4	3	2	1	0
PON	URQ	CME	EXE	DDE	QYE	RQC	OPC

The Event Status Enable Register (ESER). This register controls which types of events are summarized by the Event Status Bit (ESB) in the SBR. Use the *ESE command to set the bits in the ESER. Use the *ESE? query to read the register.

Event Status Enable Register (ESER)

7	6	5	4	3	2	1	0
PON	URQ	CME	EXE	DDE	QYE	RQC	OPC

The Service Request Enable Register (SRER). This register controls which bits in the SBR generate a Service Request and are summarized by the Master Status Summary (MSS) bit.

Use the *SRE command to set the SRER. Use the *SRE? query to read the register. The RQS bit remains set to one until either the Status Byte Register is read with a Serial Poll or the MSS bit changes back to a zero.

Service Request Enable Register (SRER)

7	6	5	4	3	2	1	0
-----	-----	ESB	MAV	-----	-----	-----	-----

*PSC Command

The *PSC command controls the Enable Registers contents when you power on the instrument. Sending *PSC 1 sets the Enable Registers at power on as follows:

- DESER 255 (equivalent to a DESe 255 command)
- ESER 0 (equivalent to an *ESE 0 command)
- SRER 0 (equivalent to an *SRE 0 command)

Sending *PSC 0 lets the Enable Registers maintain their values in nonvolatile memory through a power cycle.

***NOTE:** To enable the PON (Power On) event to generate a Service Request, send *PSC 0, use the DESe and *ESE commands to enable PON in the DESER and ESER, and use the *SRE command to enable bit 5 in the SRER. Subsequent power-on cycles will generate a Service Request.*

Queues

The instrument status and event reporting system contains two queues: the Output Queue and the Event Queue.

Output Queue

The instrument stores query responses in the Output Queue and empties this queue each time it receives a new command or query message after an <EOM>. The controller must read a query response before it sends the next command (or query) or it will lose responses to earlier queries.

Caution: When a controller sends a query, an <EOM>, and a second query, the instrument normally clears the first response and outputs the second while reporting a Query Error (QYE bit in the ESER) to indicate the lost response. A fast controller, however, may receive a part or all of the first response as well. To avoid this situation, the controller should always read the response immediately after sending any terminated query message or send a DCL (Device Clear) before sending the second query.

Event Queue

The Event Queue stores detailed information on up to 20 events. If more than 20 events stack up in the Event Queue, the 20th event is replaced by event code 350, "Too many events."

Read the Event Queue with the EVENT? query (which returns only the event number), with the EVMSG? query, which returns the event number and a text description of the event, or with the ALLEV? query, which returns all the event numbers along with a description of the event. Reading an event removes it from the queue.

Before reading an event from the Event Queue, you must use the *ESR? query to read the summary of the event from the SESR. This makes the events summarized by the *ESR? read available to the EVENT? and EVMSG? queries, and empties the SESR.

Reading the SESR erases any events that were summarized by previous *ESR? reads but not read from the Event Queue. Events that follow an *ESR? read are put in the Event Queue but are not available until *ESR? is used again.

Event Handling Sequence

The figure below shows how to use the status and event handling system. In the explanation that follows, numbers in parentheses refer to numbers in the figure.

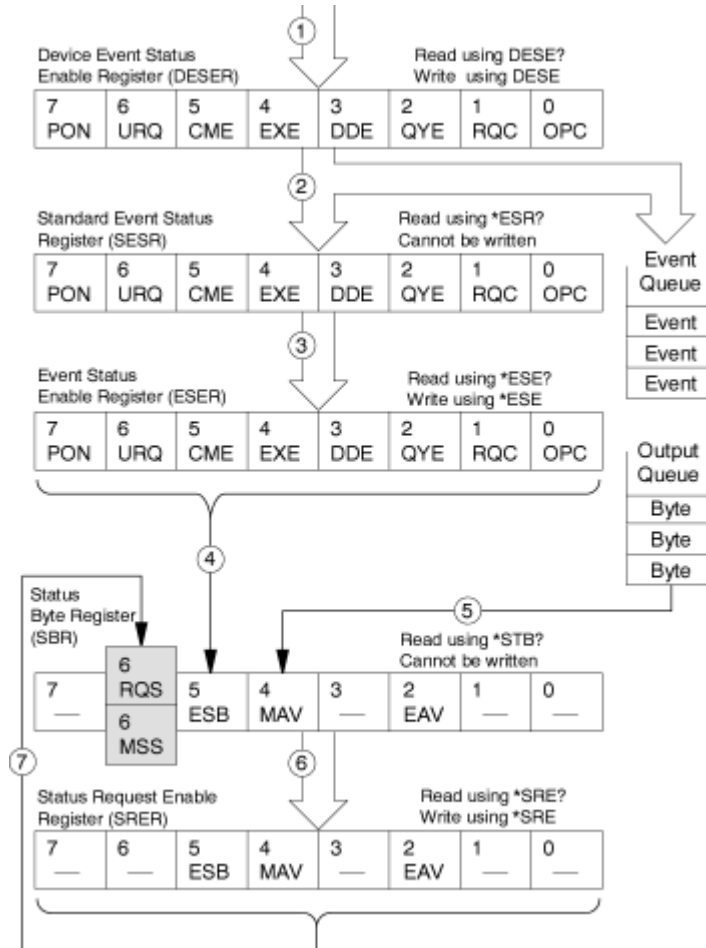

When an event occurs, a signal is sent to the DESER (1). If that type of event is enabled in the DESER (that is, if the bit for that event type is set to one), the appropriate bit in the SESR is set to one, and the event is recorded in the Event Queue (2). If the corresponding bit in the ESER is also enabled (3), then the ESB bit in the SBR is set to one (4).

When output is sent to the Output Queue, the MAV bit in the SBR is set to one (5).

When a bit in the SBR is set to one and the corresponding bit in the SRER is enabled (6), the MSS bit in the SBR is set to one and a service request is generated (7). Bit 2 of the SBR (EAV) flags the presence of events in the queue.

Synchronization Methods

Although most GPIB commands are completed almost immediately after being received by the instrument, some commands start a process that requires more time. For example, once a HARDcopy START command is executed it may be a few seconds before the hardcopy operation is complete. Rather than remain idle while the operation is in process, the instrument will continue processing other commands. This means that some operations will not be completed in the order that they were sent. Sometimes the result of an operation depends on the result of an earlier operation. The first operation must be completed before the next operation can be processed. The instrument status and event reporting system provides ways to do this.

For example, synchronization may be used to ensure that the curve? query command returns waveform data that is consistent with the current instrument settings. You could use the following sequence to do this:

```
/** Sets up conditional acquisition **/  
ACQUIRE:STATE OFF  
SELECT:CH1 ON  
HORIZONTAL:RECORDLENGTH 500  
ACQUIRE:MODE SAMPLE  
ACQUIRE:STOPAFTER:COUNT 1  
ACQUIRE:STOPAFTER:MODE CONDITION  
/** Sets up the data preamble **/  
DATA:START 1  
DATA:STOP 500  
DATA:ENCDG RIBINARY  
  
/** Clear data and acquire waveforms until conditional  
stop occurs**/  
ACQUIRE:DATA:CLEAR  
ACQUIRE:STATE ON  
/** Synchronize the operations by using *WAI, Busy?,  
*OPC, or *OPC?/  
<Synchronization command>  
/** Get the curve data **/
```

CURVE?

The acquisition of the waveform requires extended processing time. It may not finish before the instrument executes the CURVE? query (see the figure below). This can result in incorrect curve values.

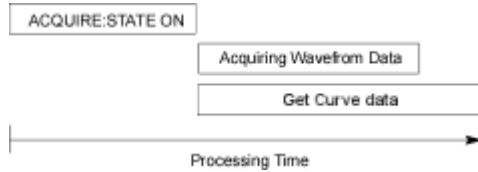

To ensure that the instrument completes waveform acquisition before attempting to execute the CURVE? query, you can synchronize the program. The figure below shows the desired processing sequence.

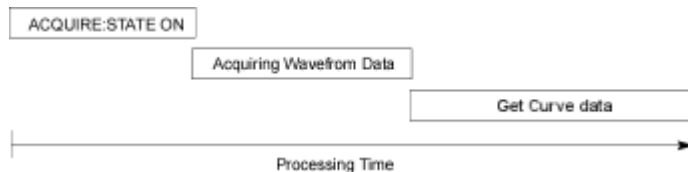

You can use four commands to synchronize the operation of the instrument with your application program: *WAI, BUSY?, *OPC, or *OPC?

*WAI Synchronization

You can force commands to execute sequentially by using the *WAI command. This command forces completion of the previous commands before processing new ones.

The same command sequence using the *WAI command for synchronization looks like this:

```
/** Sets up conditional acquisition **/  
ACQUIRE:STATE OFF  
SELECT:CH1 ON  
HORIZONTAL:RECORDLENGTH 500  
ACQUIRE:MODE SAMPLE  
ACQUIRE:STOPAFTER:COUNT 1  
ACQUIRE:STOPAFTER:MODE CONDITION  
  
/** Sets up the data preamble **/  
DATA:START 1  
DATA:STOP 500  
DATA:ENCDG RIBINARY  
  
/** Clear data and then acquire waveforms until  
conditional stop occurs**/  
ACQUIRE:DATA:CLEAR  
ACQUIRE:STATE ON  
  
/** Wait until the acquisition is complete before  
querying the curve data**/  
*WAI
```

```
/** Get the curve data **/  
CURVE?
```

Although *WAI is one of the easiest ways to achieve synchronization, it is also the most costly. The processing time of the instrument is slowed since it is processing a single command at a time. This time could be spent doing other tasks.

The controller can continue to write commands to the input buffer of the instrument, but the commands will not be processed by the instrument until all operations in process are complete. If the input buffer becomes full, the controller will be unable to write more commands to the buffer. This can cause a timeout.

BUSY? Query

The BUSY? query allows you to find out whether the instrument is busy processing a command that has an extended processing time, such as single-sequence acquisition.

The same command sequence using the BUSY? query for synchronization looks like this:

```
/** Sets up conditional acquisition **/  
ACQUIRE:STATE OFF  
SELECT:CH1 ON  
HORIZONTAL:RECORDLENGTH 500  
ACQUIRE:MODE SAMPLE  
ACQUIRE:STOPAFTER:COUNT 1  
ACQUIRE:STOPAFTER:MODE CONDITION  
/** Sets up the data preamble **/  
DATA:START 1  
DATA:STOP 500  
DATA:ENCDG RIBINARY  
/** Clear data and then acquire waveforms until  
conditional stop occurs**/  
ACQUIRE:DATA:CLEAR  
ACQUIRE:STATE ON  
/** Wait until the acquisition is complete before  
querying the curve data**/  
While BUSY? keep looping  
/** Get the curve data **/  
CURVE?
```

This sequence lets you create your own wait loop rather than using the *WAI command. The BUSY? query helps you avoid time-outs caused by writing too many commands to the input buffer. The controller is still tied up, though, and the repeated BUSY? query will result in more bus traffic.

***OPC Command**

If the corresponding status registers are enabled, the *OPC command sets the OPC bit in the Standard Event Status Register (SESR) when an operation is complete. You achieve synchronization by using this command with either a serial poll or service request handler.

Serial Poll Method: Enable the OPC bit in the Device Event Status Enable Register (DESER) and the Event Status Enable Register (ESER) using the DESE and *ESE commands.

When the operation is complete, the OPC bit in the Standard Event Status Register (SESR) will be enabled and the Event Status Bit (ESB) in the Status Byte Register will be enabled.

The same command sequence using the *OPC command for synchronization with serial polling looks like this:

```
/** Sets up conditional acquisition **/  
ACQUIRE:STATE OFF  
SELECT:CH1 ON  
HORIZONTAL:RECORDLENGTH 500  
ACQUIRE:MODE SAMPLE  
ACQUIRE:STOPAFTER:COUNT 1  
ACQUIRE:STOPAFTER:MODE CONDITION  
  
/** Enable the status registers **/  
DESE 1  
*ESE 1  
*SRE 0  
  
/** Sets up the data preamble **/  
DATA:START 1  
DATA:STOP 500  
DATA:ENCDG RIBINARY  
  
/** Clear data, and then acquire waveforms until  
conditional stop occurs**/  
ACQUIRE:DATA:CLEAR  
ACQUIRE:STATE ON  
  
/** Wait until the acquisition is complete before  
querying the curve data.**/  
*OPC  
While serial poll = 0, keep looping  
  
/** Get the curve data **/  
CURVE?
```

This technique requires less bus traffic than did looping on BUSY?.

Service Request Method: Enable the OPC bit in the Device Event Status Enable Register (DESER) and the Event Status Enable Register (ESER) using the DESE and *ESE commands.

You can also enable service requests by setting the ESB bit in the Service Request Enable Register (SRER) using the *SRE command. When the operation is complete, a Service Request will be generated.

The same command sequence using the *OPC command for synchronization looks like this:

```
/** Sets up conditional acquisition **/  
ACQUIRE:STATE OFF  
SELECT:CH1 ON  
HORIZONTAL:RECORDLENGTH 500
```

```

ACQUIRE:MODE SAMPLE
ACQUIRE:STOPAFTER:CONDITION ACQWFMS
ACQUIRE:STOPAFTER:COUNT 100
ACQUIRE:STOPAFTER:MODE CONDITION

/** Enable the status registers **/
DESE 1
*ESE 1
*SRE 0

/** Set up measurement parameters **/
MEASUREMENT:MEAS1:TYPE AMPLITUDE
MEASUREMENT:MEAS1:SOURCE CH1

/** Acquire waveforms until conditional stop occurs**/

ACQUIRE:DATA:CLEAR
ACQUIRE:STATE ON
/**Wait until the acquisition is complete before
taking the measurement**/
*OPC

/**The program can now do different tasks such as talk
to other devices. The SRQ, when it comes, interrupts
those tasks and returns control to this task.**/

/** Take amplitude measurement **/
MEASUREMENT:MEAS1:VALUE?

```

This technique is more efficient but requires more sophisticated programming.

***OPC? Query**

The *OPC? query places a 1 in the Output Queue once an operation is complete. A timeout could occur if you try to read the output queue before there is any data in it.

The same command sequence using the *OPC? query for synchronization looks like this:

```

/** Sets up conditional acquisition **/
ACQUIRE:STATE OFF
SELECT:CH1 ON
HORIZONTAL:RECORDLENGTH 500
ACQUIRE:MODE SAMPLE
ACQUIRE:STOPAFTER:COUNT 1
ACQUIRE:STOPAFTER:MODE CONDITION

/** Set up measurement parameters **/
MEASUREMENT:MEAS1:TYPE AMPLITUDE
MEASUREMENT:MEAS1:SOURCE CH1

/** Clear data, and then acquire waveforms until
conditional stop occurs**/
ACQUIRE:DATA:CLEAR
ACQUIRE:STATE ON

```

```

/** Wait until the acquisition is complete before
querying the curve data**/
*OPC?
/** Wait for read from Output Queue **/

/** Get the curve data **/
CURVE?

```

This is the simplest approach. It requires no status handling or loops. However, you must set the controller timeout for a longer period of time than that used by the acquisition operation.

Messages

The information contained in this section covers all the programming interface messages that the instrument generates in response to commands and queries.

For most messages, a secondary message from the instrument gives more detail about the cause of the error or the meaning of the message. This message is part of the message string and is separated from the main message by a semicolon.

Each message is the result of an event. Each type of event sets a specific bit in the SESR and is controlled by the equivalent bit in the DESER. Thus, each message is associated with a specific SESR bit. In the message tables, the associated SESR bit is specified in the table title, with exceptions noted with the error message text.

No-Event Messages

The following table shows the messages when the system has no events or status to report. These have no associated SESR bit.

No Event Messages	
Code	Message
0	No events to report; queue empty
1	No events to report; new events pending *ESR?

Command Error Messages

The following table shows the command error messages generated by improper syntax. Check that the command is properly formed and that it follows the rules described in the topics on command Syntax.

Command Error Messages (CME Bit 5)	
Code	Message
100	Command error
101	Invalid character
102	Syntax error
103	Invalid separator
104	Data type error
105	GET not allowed
106	Invalid program data separator
108	Parameter not allowed
109	Missing parameter
110	Command header error
111	Header separator error
112	Program mnemonic too long
113	Undefined header
114	Header suffix out of range
118	Query not allowed
120	Numeric data error
121	Invalid character in number
123	Exponent too large
124	Too many digits
128	Numeric data not allowed
130	Suffix error
131	Invalid suffix
134	Suffix too long
138	Suffix not allowed
140	Character data error
141	Invalid character data
144	Character data too long
148	Character data not allowed
150	String data error
151	Invalid string data
152	String data too long
158	String data not allowed
160	Block data error
161	Invalid block data
168	Block data not allowed
170	Expression error
171	Invalid expression
178	Expression data not allowed

Execution Error Messages

The following table lists the execution errors that may be detected during execution of a command.

Execution Error Messages (EXE Bit 4)	
Code	Message
200	Execution error
201	Invalid while in local
202	Settings lost due to RTL
210	Trigger error
211	Trigger ignored
212	Arm ignored
213	Init ignored
214	Trigger deadlock
215	Arm deadlock
220	Parameter error
221	Settings conflict
222	Data out of range
223	Too much data
224	Illegal parameter value
225	Out of memory
226	List not same length
230	Data corrupt or stale
231	Data questionable
240	Hardware error
241	Hardware missing
242	Hardware configuration error
243	Hardware I/O device error
244	Invalid printer selected
250	Mass storage error
251	Missing mass storage
252	Missing media
253	Corrupt media
254	Media full
255	Directory full
256	File name not found
257	File name error
258	Media protected
260	Expression error
261	Math error in expression
286	Program runtime error
2200	Measurement error, Measurement system error
2201	Measurement error, Zero period
2202	Measurement error, No period found
2203	Measurement error, No period, second waveform
2204	Measurement error, Low signal amplitude
2205	Measurement error, Low amplitude,

2206	Measurement error, Invalid gate
2207	Measurement error, Measurement overflow
2208	Measurement error, Waveform does not cross Mid Ref
2209	Measurement error, No second Mid Ref crossing
2210	Measurement error, No Mid Ref crossing, second waveform
2211	Measurement error, No backwards Mid Ref crossing
2212	Measurement error, No negative crossing
2213	Measurement error, No positive crossing
2214	Measurement error, No crossing
2215	Measurement error, No crossing, second waveform
2216	Measurement error, No crossing, target waveform
2217	Measurement error, Constant waveform
2218	Measurement error, Unused
2219	Measurement error, No valid edge - No arm sample
2220	Measurement error, No valid edge - No arm cross
2221	Measurement error, No valid edge - No trigger cross
2222	Measurement error, No valid edge - No second cross
2223	Measurement error, Waveform mismatch
2224	Measurement error, WAIT calculating
2225	Measurement error, No waveform to measure
2226	Measurement error, Null Waveform
2227	Measurement error, Positive and Negative Clipping
2228	Measurement error, Positive Clipping
2229	Measurement error, Negative Clipping
2230	Measurement error, High Ref < Low Ref
2231	Measurement error, no statistics available
2235	Math error, Invalid math description

2236	Math error, Reference waveform is invalid
2237	Math error, Out of acquisition memory
2241	Waveform request is invalid
2242	Data start and stop > record length
2243	This meas cannot be performed on this type of wfm
2244	Source wfm is not active
2245	Saveref error, Selected channel is turned off
2246	Saveref error, Selected channel data invalid
2248	This ref cannot be activated
2249	Reference deletion error, Waveform in use
2270	Alias error
2271	Alias syntax error
2273	Illegal alias label
2276	Alias expansion error
2277	Alias redefinition not allowed
2278	Alias header not found
2301	Cursor error, Off-screen
2303	Cursor error, Cursor source waveform is off
2304	Cursor error, Cursors are off
2321	Histogram warning, histogram turned off
2400	Not enough memory available
2401	This channel cannot be activated
2402	Math/Meas/Histo have circular definition
2410	Empty math string
2411	Syntax error in math string
2412	Semantic error in math string
2413	Math expression is too complex
2420	Histogram cannot be performed on this type of wfm
2425	Mask counting cannot be performed on this type of wfm
2430	WfmDB cannot be built on this type of wfm
2431	No Waveform Database resource available
2435	Selected Channel is not a TDR capable channel

2440	State Change – Reject Conditional Stop Action
2441	Selected Condition is Not Active
2450	Internal Clk Invalid with FrameScan active
2451	Envelope Mode Invalid with FrameScan active
2455	RTL Hardware Warning
2456	RTL Software Error – severe problem
2457	RTL Software Warning
2458	Diagnostic Error
2459	Compensation Error
2500	Mask error - Mask Margin Boundary violated
2501	TDR coerced off - TDR operation not allowed with probe attached
2502	Waveform Database Source in use
2503	No Clock Recovery available
2504	Record length incompatible with scale
2505	Autoset Execute Warning - No waveforms enabled
2506	Error saving waveform to file.
2507	FrameScan and Average Complete incompatible.
2508	Selected filter is not available.

Device Error Messages

The following table lists the device errors that can occur during instrument operation. These errors may indicate that the instrument needs repair.

Device Error Messages (DDE Bit 3)	
Code	Message
300	Device-specific error
310	System error
311	Memory error
312	PUD memory lost
313	Calibration memory lost
314	Save/recall memory lost
315	Configuration memory lost
316	RTL Hardware Error, severe problem
350	Queue overflow (does not set DDE bit)

System Event Messages

The following table lists the system event messages. These messages are generated whenever certain system conditions occur.

System Event Messages	
Code	Message
400	Query event
401	Power on (PON bit 7 set)
402	Operation complete (OPC bit 0 set)
403	User request (URQ bit 6 set)
404	Power fail (DDE bit 3 set)
405	Request control
410	Query INTERRUPTED (QYE bit 2 set)
420	Query UNTERMINATED (QYE bit 2 set)
430	Query DEADLOCKED (QYE bit 2 set)
440	Query UNTERMINATED after indefinite response (QYE bit 2 set)

Execution Warning Messages

The following table lists warning messages that do not interrupt the flow of command execution. These notify you that you may get unexpected results.

Execution Warning Messages (EXE Bit 4)	
Code	Message
500	Execution warning
510	String data too long, truncated
525	Parameter underrange
526	Parameter overrange
527	Parameter rounded
528	Parameter out of range
530	Data stop > start. Values swapped internally
531	Data stop > record length, Curve truncated
532	Curve data too long, Curve truncated
540	Measurement warning
541	Measurement warning, Low signal amplitude
542	Measurement warning, Unstable histogram
543	Measurement warning, Low resolution
544	Measurement warning, Uncertain edge
545	Measurement warning, Invalid in minmax
546	Measurement warning, Need 3 edges
547	Measurement warning, Clipping positive/negative
548	Measurement warning, Clipping positive
549	Measurement warning, Clipping negative

Internal Warning Messages

The following table shows internal errors that indicate an internal fault in the instrument.

Internal Warning Messages	
Code	Message
600	Internal warning

Miscellaneous

Reserved Words

This topic is a list of reserved words for the CSA8000 and TDS8000 instruments. Capital letters identify the required minimum spelling. For the most robust code use the full spelling, since spelling rules may change over time and from instrument model to instrument model.

*CLS – DARKLev

*CLS	AOPTPWRDBM	BELL	CLEAR
*ESE	ALL	BINary	CLKRec
*ESR	ALLEv	BIT_Nr	CLKRECovery
*IDN	Amp	BITTime	CMEan
*LRN	AMPLitude	BITRate	COLOR
*OPC	ANNOtations	BITS	COMPensate
*PSC	AOPTpwr	BN_Fm	CONDition
*RST	AREa	BOX	CONTROL
*SRE	ASCIi	BOXPent	COUNT
*STB	AUTO	BURst	CRMs
*TST	AUTOPosition	BUSY	CROSSHair
*WAI	AUTOSet	BYT_Nr	CURRentcount
ABSolute	AVERage	BYT_Or	CURSor
ACQHWver	AVG	CALibrate	CURSReadout
ACQuire	AVGComp	CAPacitance	CURVVe
ACQWfms	BACKground	CAREa	DARKLev
ACRMs	BACKward	CENTERed	
ACTion	BANDwidth	CH	

DATA-GRid

DATA	ENCdg	EYEHeight	FILTer
DATE	ENET10313	EYEOfactor	FOREground
DB	ENET1250	EYEWIdth	FORward
DCCALibrator	ENET3125	EYEWindow	FP
DEFine	ENET9953	FACTory	FPAnel
DELay	ENV	FALL	FPANversion
DELTA	EVENT	FC1063	FPBinary
DESE	EVMsg	FC1063e	FRAME
DESkew	EVQty	FC133	FRAMEScan
DESTination	EXECute	FC133E	FREQuency
DIAG	EXPort	FC2125	FULl
DIEL	EXT10MHZref	FC266	FUNCTION
DIRection	EXTAtten	FC266E	GAIN
DISPlay	EXTDirect	FC4250	GATE

DIST	EXTender	FC531	GATing
DISTDUty	EXTINCTDB	FC531E	GRADing
DYNAmic	EXTINCTPCT	FEC10664	GRAticule
EDGe	EXTINCTRATIO	FEC10709	GRId
EITHer	EXTPrescaler	FEC2666	
EMPHasis	EYE	FEC42657	
ENABle	EYECross	FILEName	

GRoup – MEASAnnotation

GRoup	HORizontal	LIST	MASK3Hits
HALT	HOSTinfo	LISTValue	MASK4Hits
HARDCopy	HPOS	LOCK	MASK5Hits
HBArS	ID	LOCKExt	MASK6Hits
HDELTA	IMPedance	LOCKInt	MASK7Hits
HDIVS	INFIniband	LODelta	MASK8Hits
HEADer	INFPersist	LOG	MASKHits
HIDelta	INKSaver	LOOP	MASKReadout
HIFreq	INIT	LOW	MASKSamples
HIGH	INTCik	LSB	MASKTOTalhit
HILow	INTensity	MAG	MASKWaveform
HISTHits	INTERPolat	MAIn	MASKWfms
HISTogram	INTRate	MAINframe	MATH
HISTRReadout	INVert	MANual	MAXimum
HISTWaveform	JITter	MARgin	MEAN
HISTWfms	LEVel	MASK	MEAS
HITS	LEVCROSS	MASK1Hits	MEASAnnotation
HOLDoff	LINear	MASK2Hits	

MEASBar - REF

MEASBar	NOVershoot	ONTime	POINTSPent
MEASReadout	NR_Pt	OPERating	POSition
MEDIAN	NUMAVg	OPTGAIN	POVershoot
METAReject	NWIdth	PCROSS	POWERups
METHod	OC1	PCTCROSS	PRINTScreen
MID	OC12	PCTPOS	PRObe
MIDref	OC18	PDUty	PROCHWver
MINimum	OC192	PEAKHits	PROPerties
MINMax	OC24	PERCent	PT_Fmt
MINUS	OC3	PERIod	PULSESym
MODE	OC36	PERSistence	PVEL
MODElnum	OC48	PHAsE	PWIdth
MSB	OC768	PK2pk	QFACtor
NCROSS	OC9	PKPKJitter	RECAI
NDUty	OC96	PKPKNoise	RECOrdLength

NOISe	OFF	PKTOPK	REF
NONDestruct	OFFSet	PLUS	
NONe	Ohm	PNG	
NORMAl	ON	POInts	

REFLevel - TOTAl

REFLevel	SAMple	SIGMA	STOPAfter
REFPoint	SAVE	SIGType	STYLE
RELative	SAVEFile	SINX	SUPRSRATIO
RESET	SAVEScreen	SIZE	SUPRSDB
RESolution	SAVEWaveform	SLOPe	SUPRSPCT
RESults	SAVEWfm	SNAp	SWVersion
Rho	SCALE	SNRatio	SYNC
RI	SCANBits	SOURce	SYSTEM
RIBinary	SElect	SRIBinary	TBMode
RISe	SERialnum	STANDard	TEKPDriver
RISetime	SET	START	TEKPVersion
RMS	SETDefault	START	TEMPerature
RMSJitter	SETLevel	STARTBit	TEST
RMSNoise	SETup	STATE	TIME
RP	SFPBinary	STATistics	TIMCROSS
RUN	SHIFted	STATus	TOFPoint
RUNSTop	SHORTTerm	STDdev	TOLPoint
S	SHOWVector	STOP	TOTAL

TOTALontime - YZEro

TOTALontime	VIEW	XOFF
TOUCH	Volt	XUNit
TRACK	Watt	XZEro
TRIGger	WAVEFORM	Y
TYPE	WAVEforms	YMULT
UNDEFined	WAVFrm	YOFF
UNDO	WEIGHTing	YSCALE
UNIts	WFId	YUNit
UNLock	WFM	YZEro
UPDATEinfo	WFMDB	
USER	WFMinpre	
USERMask	WFMLabel	
VBArs	WFMOutpre	
VDELTA	WFMReadout	
VDIVS	WLENgth	
VERBose	XINcr	
VERTical	XMULT	

Factory Default Setup Values

This topic contains tables that list the default setup values by command group. These are the values that the instrument sets when you press the DEFAULT SETUP front-panel button or send the FACTORY command. Only those commands that have values set by the DEFAULT SETUP function are listed in these tables.

Acquisition Values

Default Setup Values	
Command	Default
ACQuire:MODE	SAMple
ACQuire:NUMAVg	16
ACQuire:SAVEFile:SAVEScreen	""
ACQuire:SAVEFile:SAVEWfm	""
ACQuire:STATE	1 (ON)
ACQuire:STOPAfter:ACTion	NONE
ACQuire:STOPAfter:BELL	0 (OFF)
ACQuire:STOPAfter:CONDition	ACQWfms
ACQuire:STOPAfter:COUNt	1
ACQuire:STOPAfter:MODE	RUNSTop

Cursor Values

Default Setup Values	
Command	Default
CURSor:CURSor<x>:COLOr	5
CURSor:CURSor<x>:SOUrce	CH1,MAIN
CURSor:FUNction	0 (OFF)
CURSor:HBArs:POSition1	-1.621616E-001
CURSor:HBArs:POSition2	1.702702E-001
CURSor:SELEct	NONE
CURSor:VBArS:POSition1	1.965E-008
CURSor:VBArS:POSition2	2.130E-008
CURSor:WAVeform:POSition1	1.965E-008
CURSor:WAVeform:POSition2	2.130E-008

Display Values

Default Setup Values	
Command	Default
DISplay:COLor:BACKGround	0 (black)
DISplay:COLor:CURSor1	5 (red)
DISplay:COLor:CURSor2	5 (red)
DISplay:COLor:FOREGround	15 (white)
DISplay:COLor:HISTogram	2 (blue)
DISplay:COLor:MASK	4 (fuchsia)
DISplay:CURSReadout	0 (OFF)
DISplay:GRAticule:STYle	FULL
DISplay:HISTRReadout	0 (OFF)
DISplay:INTERPolat	SINX
DISplay:MASKReadout	0 (OFF)
DISplay:MEASBar	0 (OFF)
DISplay:MEASReadout	0 (OFF)
DISplay:PERsistence	2.000E+002
DISplay:SHOWVector	0 (OFF)
DISplay:STYle	NORMal
DISplay:WFMRReadout	0 (OFF)

Histogram Values

Default Setup Values	
Command	Default
HIStogram:BOX	0 (OFF)
HIStogram:BOXPnt	3.000E+001, 2.510E+001, 7.000E+001, 7.520E+001
HIStogram:COLOr	2 (blue)
HIStogram:DISPlay	0 (OFF)
HIStogram:ENABle	0 (OFF)
HIStogram:MODe	HORizontal
HIStogram:SIZe	2
HIStogram:SOUrce	CH1,MAIN
HIStogram:TYPE	LINEAr
HIStogram:WFMDB:STATE	0 (OFF)

Horizontal Values

Default Setup Values	
Command	Default
HORizontal:BITS:BITRate	2.488E+009
HORizontal:BITS:STANdard	NONE
HORizontal:DIStance:DIElectric	1
HORizontal:DIStance:PVELocity	2.998e+10
HORizontal:EXT10MHZrefFREQ	1.000E+007
HORizontal:FRAMescan:AUTOPosition	0 (OFF)
HORizontal:FRAMescan:SCANBits	64
HORizontal:FRAMescan:STARTRBit	4.600E+001
HORizontal:FRAMescan:STATE	0 (OFF)
HORizontal:MAG<>:POSITION	1.875E-008
HORizontal:MAG<>:RECORDlength	500
HORizontal:MAG<>:REFPoint	5.000E-001
HORizontal:MAG<>:SCALE	5.000E-011
HORizontal:MAG<>:VIEW	0 (OFF)
HORizontal:MAIn:POSITION	2.050E-008
HORizontal:MAIn:RECORDlength	500
HORizontal:MAIn:REFPoint	50
HORizontal:MAIn:SCALE	5.000E-010
HORizontal:TBMODE	SHORTTerm
HORizontal:UNITS	S

Mask Values

Default Setup Values	
Command	Default
MASK:AUTOSet:MODE	MANual
MASK:COLOR	4 (fuchsia)
MASK:COUNT:STATE	0 (OFF)
MASK:DISPlay	0 (OFF)
MASK:MARGIN:PERCent	5.000E+000
MASK:MARGIN:STATE	0 (OFF)
MASK:SOURce	CH1,MAIn
MASK:STANdard	NONE
MASK:WFMDB:STATE	0 (OFF)

Math Values

Default Setup Values	
Command	Default
MATH<>:DEFine	" "
MATH<>:FILTER:MODE	CENTERed
MATH<>:NUMavg	2
MATH<>:POSITION	0.00E+000
MATH<>:POSITION	0.5
MATH<>:SCALE	1.000E+000
MATH<>:SCALE	1

Measurements Values

Default Setup Values	
Command	Default
MEASUREMENT:ANNOTATIONS:STATE	0 (OFF)
MEASUREMENT:MEAS<xx>:EYEWINDOW	20
MEASUREMENT:MEAS<xx>:GATING:STATE	0 (OFF)
MEASUREMENT:MEAS<xx>:JITTER	EYECROSS
MEASUREMENT:MEAS<xx>:NOISE	HIGH
MEASUREMENT:MEAS<xx>:REFLEVEL11:ABSOLUTE:HIGH	0.000E+000
MEASUREMENT:MEAS<xx>:REFLEVEL11:ABSOLUTE:LOW	0.000E+000
MEASUREMENT:MEAS<xx>:REFLEVEL11:RELATIVE:HIGH	9.000E+001
MEASUREMENT:MEAS<xx>:REFLEVEL11:RELATIVE:LOW	1.000E+001
MEASUREMENT:MEAS<xx>:REFLEVEL<xx>:ABSOLUTE:MID	0.000E+000
MEASUREMENT:MEAS<xx>:REFLEVEL<xx>:METHOD	RELATIVE
MEASUREMENT:MEAS<xx>:REFLEVEL<xx>:RELATIVE:MID	5.000E+001
MEASUREMENT:MEAS<xx>:SOURCE<xx>:EDGE:IRECTION	FORWARD
MEASUREMENT:MEAS<xx>:SOURCE<xx>:EDGE:SLOPE	RISE
MEASUREMENT:MEAS<xx>:SOURCE<xx>:GATE1:PCTPOS	
MEASUREMENT:MEAS<xx>:SOURCE<xx>:GATE1:POS	1.800E-008
MEASUREMENT:MEAS<xx>:SOURCE<xx>:GATE2:PCTPOS	
MEASUREMENT:MEAS<xx>:SOURCE<xx>:GATE2:POS	2.300E-008
MEASUREMENT:MEAS<xx>:SOURCE<xx>:HILowMETHOD	AUTO
MEASUREMENT:MEAS<xx>:SOURCE<xx>:HILowTRACK:HIGH:ENABLE	0 (OFF)
MEASUREMENT:MEAS<xx>:SOURCE<xx>:HILowTRACK:HIGH:VALUE	0.000E+000
MEASUREMENT:MEAS<xx>:SOURCE<xx>:HILowTRACK:LOW:ENABLE	0 (OFF)
MEASUREMENT:MEAS<xx>:SOURCE<xx>:HILowTRACK:LOW:VALUE	0.000E+000
MEASUREMENT:MEAS<xx>:SOURCE<xx>:WFM	CH1_MAIN
MEASUREMENT:MEAS<xx>:SOURCE<xx>:WFMDB:SIGTYPE	PULSE
MEASUREMENT:MEAS<xx>:SOURCE<xx>:WFMDB:STATE	0 (OFF)
MEASUREMENT:MEAS<xx>:STATE	0 (OFF)
MEASUREMENT:MEAS<xx>:TYPE	UNDEFINED
MEASUREMENT:STATISTICS:ENABLE	0 (OFF)
MEASUREMENT:STATISTICS:WEIGHTING	32

Miscellaneous Values

Default Setup Values	
Command	Default
AUTOSet:TYPE	PERIOD
HARDCopy:FORMAT	BMP
HARDCopy:INKSAVER	0 (OFF)
HEADER	0 (OFF)
LOCK	FPANEL
VERBOSE	1 (ON)

Status and Error Values

Default Setup Values	
Command	Default
DE SE	255
*ESE	0
*SRE	0

TDR Values

Default Setup Values	
Command	Default
TDR:CH<x>:STEP:DESkew	0.000E+000
TDR:CH<x>:STEP:POLarity	PLUS
TDR:CH<x>:STEP:STATE	0 (OFF)
TDR:CH<x>:UNIts	RHO
TDR:INTRate	200

Trigger Values

Default Setup Values	
Command	Default
TRIGger:CH(1-2):CLKRec:VALue	NONE
TRIGger:CLKRec:SOUrce:CH<x>	CH1
TRIGger:GATed	0 (OFF)
TRIGger:HIFreq	0 (OFF)
TRIGger:HOLDoff	5.000E-006
TRIGger:INTRate	200
TRIGger:LEVel	0.000E+000
TRIGger:METAReject	0 (OFF)
TRIGger:MODe	AUTO
TRIGger:SLOpe	RISE
TRIGger:SOUrce	EXTDirect

Vertical Values

Default Setup Values	
Command	Default
CH<x>:BANdwidth:VALue	1.000E+032
CH<x>:DESKew	0.000E+000
CH<x>:EXTAtten:VALue	1.00E+000
CH<x>:EXTDAtten:MODE	LINEar
CH<x>:FILTer:VALue	NONE
CH<x>:OFFSet	0.000E+000
CH<x>:POSition	0.000E+000
CH<x>:SCAle	1.000E-000
CH<x>:UNIts	AUTO
CURVe	ascii
DATa	NA
DATa:DESTintation	REF1
DATa:ENCdg	ASCLi
DATa:SOUrce	CH1
DATa:STARt	1
DATa:STOP	500
REF<x>:POSition	0.000000016
REF<x>:SCAle	5E-10
SElect:CH<x>	0
SElect:CONTRol	NONE,MAIn
SElect:MATH<x>	0
SElect:REF<x>	0

Waveform Database Values

Default Setup Values	
Command	Default
WFMDB:DISplay:EMPHAsis	50
WFMDB:DISplay:GRADing	COLor
WFMDB:DISplay:INVert	0 (OFF)
WFMDB:WFMDB<x>:DISplay	0 (OFF)
WFMDB:WFMDB<x>:ENABLe	0 (OFF)
WFMDB:WFMDB<x>:SOUrce	CH1,MAIn

Waveform Transfer Values

Default Setup Values	
Command	Default
WFMInpre:BIT_Nr	32
WFMInpre:BN_Fmt	RI
WFMInpre:BYT_Nr	4
WFMInpre:BYT_Or	LSB
WFMInpre:ENCdg	ASCII
WFMInpre:NR_Pt	500
WFMInpre:PT_Fmt	Y
WFMInpre:WFMLabel	NA
WFMInpre:XINcr	0.000E+000
WFMInpre:XMULT	1.000E-010
WFMInpre:XOFF	1.600E-0080
WFMInpre:XUnit	""
WFMInpre:XZEro	1.600E-0008
WFMInpre:YMULT	1.000E-001
WFMInpre:YOFF	0
WFMInpre:YSCALE	0.000E+000
WFMInpre:YUnit	""
WFMInpre:YZEro	0.00E+000
WFMOutpre:BIT_Nr	32
WFMOutpre:BN_Fmt	RI
WFMOutpre:BYT_Nr	4
WFMOutpre:BYT_Or	LSB
WFMOutpre:ENCdg	ASCII
WFMOutpre:WFMLabel	""

GPIB Interface Specifications

This topic describes details of the GPIB remote interface of the instrument. Normally, you will not need this information to use the instrument, but this information may be useful if you are connecting to controllers with unusual configurations.

GPIB Functions

The following table lists the GPIB interface functions and electrical functions subsets supported by this instrument with a brief descriptions of each.

 GPIB Functions 		
Interface Function	Subset	Meaning
Acceptor Handshake	AH1	The instrument can receive multiline messages across the GPIB from other devices.
Controller	C0	No Controller capability; the instrument cannot control other devices.
Device Clear	DC1	The instrument can respond to both the DCL (Device Clear) interface message and to the Selected Device Clear (SDC) interface message when the instrument is listen-addressed.
Device Trigger	DT0	No Device Trigger capability; the instrument does not respond to the GET (Group Execute Trigger) interface message.
Electrical	E2	The instrument uses tri-state buffers, which are optimal for high-speed data transfer.
Listener	L4	The instrument becomes a listener when it detects its listen address being sent over the bus with the ATN line asserted. The instrument ceases to be a listener and becomes a talker when it detects its talk address being sent over the bus with the ATN line asserted.
Parallel Poll	PP0	No Parallel Poll capability; the instrument does not respond to PPC (Parallel Poll Configure), PPD (Parallel Poll Disable), PPE (Parallel Poll Enable), or PPU (Parallel Poll Unconfigure) interface messages, nor does it send a status message when the ATN and EOI lines are asserted simultaneously.
Remote/ Local	RL1	The instrument can respond to both the GTL (Go To Local) and LLO (Local Lock Out) interface messages.
Service Request	SR1	The instrument can assert the SRQ line to notify the controller in charge that it requires service.
Source Handshake	SH1	The instrument can initiate multiline messages to send across the GPIB to other devices.
Talker	T5	The instrument becomes a talker when it detects its talk address being sent over the bus with the ATN line asserted. The instrument ceases to be a talker and becomes a listener when it detects its listen address being sent over the bus with the ATN line asserted. The instrument also ceases to be a talker when it detects another device's talk address being sent over the data lines with ATN asserted.

Interface Messages

The following table shows the standard interface messages that the instrument supports.

Standard Interface Messages	
Message	GPiB
DCL	Yes
GET	Yes
GTL	Yes
LLO	Yes
PPC	No
PPD	No
PPE	No
PPU	No
SDC	Yes
SPD	Yes
SPE	Yes
TCT	No
UNL	Yes
UNT	Yes
Listen Addresses	Yes
Talk Addresses	Yes

Programming Examples

The CSA8000B and TDS8000B instruments come with sample programs that illustrate methods that you can use to control either instrument from the GPIB interface.

The following topics are covered:

- Descriptions of the Sample Programs
- To Run the Sample programs
- To Copy the Sample-Program Code to Your Programs

Descriptions of the Sample Programs

The programs were written in Microsoft Visual C++, version 6.0, and were generated using the AppWizard program. Both program listings and source codes are included on the product software CD-ROM that comes with each instrument. A description of each program follows:

Sample Programs:		
Name	Function	Module
Meas	Performs a timing or an amplitude measurement on the selected waveform and displays the results.	Any 80E00
WfmTransfer	Transfers the horizontal timebase and its vertical scale of the selected waveform to a file on your PC (controller).	Any 80E00
Capture	Captures the instrument screens and prints ¹ it or saves it as a file on your instrument (not your controller).	Any 80E00
TDR	Displays the attached cable length in centimeters.	80E04 only
Mask	Makes an eye pattern evaluation against a mask, looking for a "stops after" condition you specify. Upon fulfillment of the stop after condition, the program can print ¹ the result or can save it as a file on your instrument (not your controller).	² Any 80C00

¹To print, make sure that you have a default printer selected for your instrument before running this program.

²80C01-CR module is preferred for use with this program.

To Run the Sample Programs

1. Find the product-software CD-ROM included with your instrument.
2. Find the self-extracting archive file named TDSCSA8000.exe on the CD.
3. Click the self-extracting archive to execute it. In the dialog that displays, accept the default installation directory or browse to your alternative location on your computer/controller. To run the programs, your computer/controller must be a PC-compatible system

equipped with a National Instruments GPIB board and associated drivers.

4. Ensure that:
 - the instrument is set as DEV1 with address of 1, and that the PC (controller) is set as GPIB0
 - a valid signal is connected to the instrument

Navigate to the **Sources** directory contained in the TDSCSA8000 directory that you extracted.

Click to execute the program that you wish to run. The program will display a dialog box from which you can set up and run the program.

Note. To reassign the name of your instrument, you can, enter your current device name into the appropriate edit box within each program (except the Mask program, where the board address is hard-coded to zero). You can also use IBCONF.EXE to reassign the name.

To Copy the Sample-Program Code to Your Programs

1. Do steps 1 through 3 of the procedure *To Run the Sample Programs* if you have not yet installed the TDSCSA8000 directory containing the programs.
2. Navigate to the **Programs** directory contained in the TDSCSA8000 directory.
3. Open the program file in your favorite editor or IDE, and copy the code you want into your programs.

Index

*CLS	57
*ESE	57, 58
*ESR?	58
*IDN?	59
*LRN?	59
*OPC	59, 60
*PSC	60, 61
*RST	61
*SRE	62
*STB?	62
*WAI	63
ACQuire	
MODe	67, 68, 69
SAVEFile	
SAVEScreen	70
SAVEWfm	71
STOPAfter	
ACTion	72, 73
BELL	73, 74
CONDition	74, 75
COUNT	76
MODE?	77
STOPAfter?	77
ACQuire?	78
ALLEv?	79
Argument Type	
block	23
numeric	22, 23
quoted string	23
AUTOSet	79
Backus-Naur Form (BNF) notation	16
BUSY?	81, 82
CALibrate	
UPDATEinfo	
ALL	85
MAInframe	86
CH<x>	
BANdwidth	
VALue	87, 88
DESkew	88, 89

EXTAtten	
MODE.....	89
VALue.....	89, 90
OFFSet	93, 94
POSition	94, 95
SCAlle	95, 96
UNIts.....	96, 97
WLENgth	
VALue.....	98
CH<x>?.....	99
Command and Query Structure	
colon	
leading	17
header.....	17
messages.....	17
set form	17
Command Entry	
concatenating.....	19
Command Error Messages	348
Command Group	
Acquisition	25, 26
Calibration	26, 27
Compensation	27, 28
Cursor	29
Hardcopy	31
Histogram	32, 33
Horizontal	34, 35, 36, 37
Mask	38, 39
Math	39, 40
Measurement.....	41, 42, 43
TDR.....	48
Trigger	49
Vertical.....	51
Waveform Database	53
Waveform Transfer	55
COMPensate	
ALL	99
MAInframe.....	101
RECAII	
FACTory	
ALL	102
MAInframe	102
USER	

ALL	102
MAInframe	103
SAVE	
USER	
ALL	104
MAInframe	105
Concatenating commands and queries	19
Copyright	11
CURSor	106, 107, 110, 111
CURSor<x>	
COLOR	106, 107
SOUrce	108
FUNctIon	109
HBArS	
POSition	110
CURSor?	115
CURVe	116, 117
DATa	117, 118
DESTination	118
ENCdg	119
SOUrce	120, 121
STOP	121, 122
DATE	123, 124
<i>DELEte</i>	
<i>WAVEform</i>	124
DESE	125
DISplay	
COLor	
BACKground	125, 126
FOREground	128, 129
HIStogram	129, 130
MASK	130, 131
GRAticule	
STYLE	133, 134
PERSiStence	139
STYLE	140, 141
DISplay?	142
Documentation	15
Enable Registers	340
End-of-message terminator	20
Event Queue	342
EVENT?	142
EVMsg?	143

EVQty?	143
EXPort	144
FACTory	144, 145
GPIB	
Functions	366
HARDCopy	
FILEName	146, 147
FORMat	147, 148
STARt	146
HEADer	149
command	17
HIStogram	
BOX	150
COLOR	152, 153
COUNT	153
DISplay	153, 154
MODE	155
SIZE	155, 156
SOURCE	156, 157
HIStogram?	162
HORizontal	
BITS	
STANdard	163, 164, 165, 166
MAG<x>	
POSition	171, 172, 173
SCAle	176, 177
VIEW	179, 180
MAIn	
POSition	180, 181, 182
SCAle	185, 186
UNIts	201
HORizontal?	202
ID?	202, 203
Ink-saver	148, 149
Interface messages	348, 368
LOCK	203
MASK	
COLOR	204, 205
COUNT	
STATE	206
DISplay	208
MARGin	
STATE	209

MASK<x>	
POInts.....	212
SOURce.....	213
STANdard.....	214, 215, 216, 217, 218
MASK?.....	218, 219
MATH<x>	
DEFine.....	219
FILTer	
MODe.....	220, 221
RISetime.....	221
POSition.....	222, 223
SCAle.....	223, 224, 225
MATH<x>?.....	227
MEASUrement	
LIST.....	228, 229
MEAS<x>	
GATing	
STATE.....	231
JITter.....	232, 233
NOISe.....	234, 235
REFLevel<x>	
ABSolute	
HIGH.....	235, 236
LOW.....	236
MID.....	236, 237
METHod.....	237, 238, 239
RELative	
HIGH.....	239, 240
LOW.....	240, 241
MID.....	241, 242
SOURCE<x>	
EDGE	
DIRection.....	242, 243
SLOPe.....	244
HILow	
METHod.....	248, 249, 250
TRACK	
HIGH	
VALue.....	251, 252
LOW	
VALue.....	253, 254
TYPE.....	259, 260
STATIstics	

WEIGHTing	267
MEASUrement?	268
Messages	
Command Error.....	348
System Event.....	354
Mnemonics	20, 21, 22
channel	20, 22
cursor position.....	20
histogram statistics specifier	21
magnified timebase specifier	21
mask specifier	21
math waveform.....	22
measurement specifier	21
reference waveform	22
waveform database.....	22
Numeric arguments.....	22, 23
Output Queue.....	341
Queries.....	18
Queues	
Event	341, 342
Output.....	341
RECALL	
SETUp	268, 269
WAVEform.....	269
REF<x>	
POSition	269, 270
SCAlE	270, 271
Registers	
Enable.....	338, 340, 341
Event Status Enable Register (ESER)	340
Events.....	338
Service Request Enable Register (SRER)	341
Status.....	338, 339
Status Byte Register (SBR).....	338, 339
Remote Communications.....	12
Rules.....	18
Sample Programs	369, 370
SAVe	
SETUp	271, 272
WAVEform.....	272, 273
SElect	
CONTROl.....	274

SElect?	277
Sequence	
event handling.....	342
SET?	278
Standard Event Status Register (SESR)	338
Status and Events	
Messages	348
Registers	338
Status Registers	338
symbols	
Backus-Naur	16
SYNC	
TIMEOUT	278, 279, 280
Synchronization Methods	
using the *OPC command.....	346
using the *OPC? query	347
using the *WAI command	344
using the BUSY? query	345
Syntax	16
System Event Messages	354
TDR	
CH<x>	
PRESET.....	290
STEP	
DESkew	291
POLarity.....	291, 292
UNIts	293, 294
TDR?.....	294, 295
TIME	295
TRIGger	299, 300
CH<x>	
CLKRec	
VALue.....	296, 298
CLKRec	
SOUrce	298, 299
GATEd	299, 300
HOLDoff	301, 302
LEVel	303, 304
MODE	305
SLOpe.....	306, 307
SOURce.....	307, 308
TRIGger?	309
UNLock	309

VERBose	309, 310
Version of the online Programmers Guide	1
WAVFrm?	310
WFMDB	313
DISPlay	
EMPHasis	311
GRADing	312
INVert	313
WFMDB<x>	
DISPlay	314, 315
SOURce	315, 316
WFMDB?	317
WFMInpre	
XINcr	323
YSCALE	326
WFMInpre?	328
WFMOutpre?	337

